

Crestron MMK-1000L & WMKM-1000L Mud Mount Kits

Installation Guide



Contents

Mud Mount Kits: MMK-1000L & WMKM-1000L	1
Description.....	1
Setup.....	2
Supplied Hardware.....	2
Installation.....	4
Resources.....	12
Industry Compliance.....	12
Reference Documents.....	12
Further Inquiries.....	12
Future Updates.....	12
Return and Warranty Policies.....	13
Merchandise Returns / Repair Service.....	13
CRESTRON Limited Warranty.....	13

All brand names, product names and trademarks are the property of their respective owners.
©2008 Crestron Electronics, Inc.

Mud Mount Kits: MMK-1000L & WMKM-1000L

Description

Mud Mount Kits are the preferred mounting option for the Crestron® APAD LCD controller when the cutout made in the drywall for controller installation is too large. These kits provide support for additional plastering that can be applied to hide large irregularities in the controller cutout.

NOTE: If mounting into a material other than drywall (for example, wood lectern, concrete or rock) use the cutout template, available in the post-construction kit WMKM-1000L. For concrete and rock mounting material, allow for proper ventilation before mounting the controller.

There are two Mud Mount Kits. The MMK-1000L is a pre-construction accessory. Pre-construction refers to framed walls prior to hanging drywall. This accessory must be used with either the Pre-Construction Mount Kit (PMK-1000L) or Back Box (BB-1000L).

The WMKM-1000L is a post-construction kit. Post-construction refers to framed walls with drywall hung. This accessory is designed with a mounting plate so that it can be placed anywhere on a wall without the support of a stud.

NOTE: If necessary, consult the latest revision of the APAD Installation and Operations Guide (Doc. 6455) for a complete list of mounting options. The document is available from the Crestron website (<http://www.crestron.com/manuals>).

Setup

Supplied Hardware

The MMK-1000L consists of three parts. These parts produce an assembly that attaches to the BB-1000L or PMK-1000L. The WMKM-1000L consists of six parts, three of which make up the MMK-1000L, as well as a mounting plate, a set of mounting screws and a cutout template set.

The mounting plate provides the necessary support for post-construction applications. Two overlay cutout templates (2005028) are supplied. One is in the shape of the required opening; the other is similar to a frame, with the inner area of the frame the shape of the required opening. (Refer to the illustrations on pages 3 and 4.) Use the template that is most convenient.

Supplied Hardware for the MMK-1000L and WMKM-1000L

DESCRIPTION	PART NUMBER	QUANTITY
Metal, Plate, Mud Ring	2004810	1
Metal Plate, Adjustment	2004808	2
Hardware, Metal, U-Type Adjustment	2004121	4
Metal, Plate, Mounting Bar (WMKM-1000L only)	2014807	1
Screw, #04-40 x 2", Pan, Phil (WMKM-1000L only)	2018793	4
Overlay, Template, Wall Cutout (WMKM-1000L only)	2005028	1

The dimensions of the MMK-1000L/WMKM-1000L are shown below and on the next page.

Dimensional Drawing – Mud Ring Plate

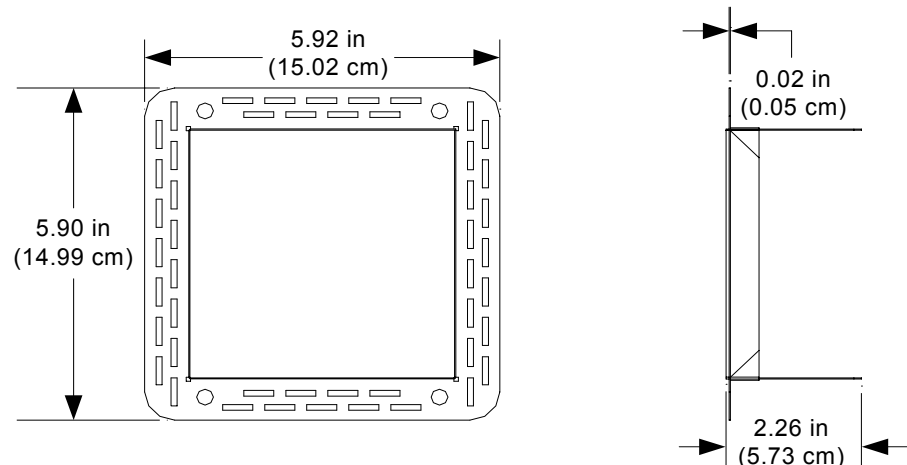

Dimensional Drawing – Adjustment Plate

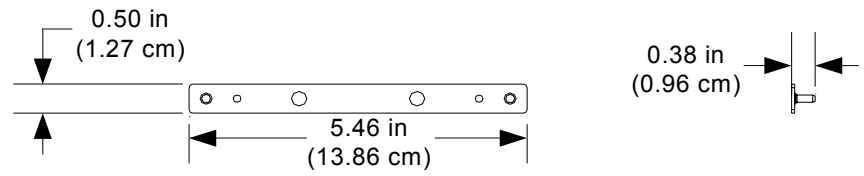

Dimensional Drawing – Mounting Plate

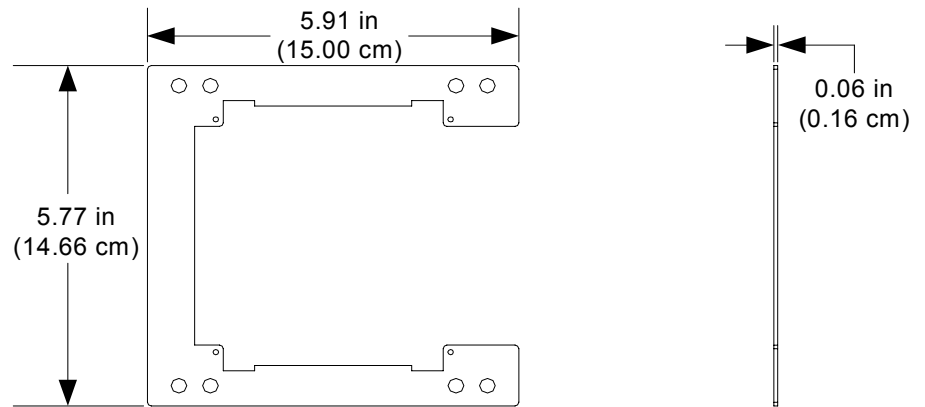

Drywall Cutout Template and Dimensions (supplied with WMKM-1000L only), 1 of 2

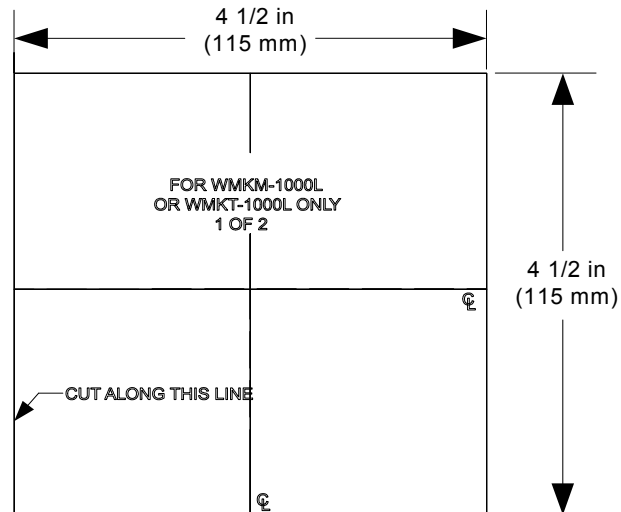

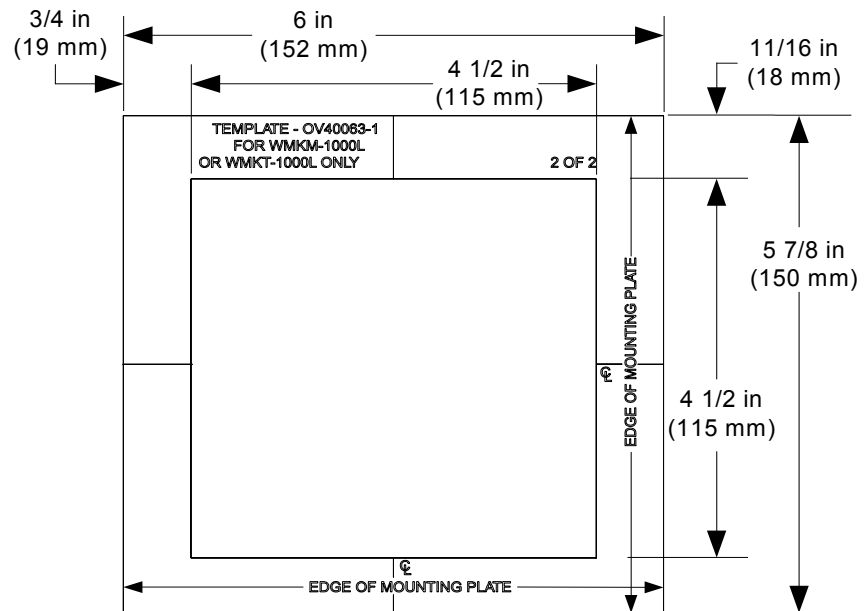
Drywall Cutout Template and Dimensions (supplied with WMKM-1000L only), 2 of 2

Installation

This section provides an installation procedure for each Mud Mount Kit. The “MMK-1000L Procedure” starts below and the “WMKM-1000L Procedure” starts on page 7. Be sure to review each procedure before starting.

MMK-1000L Procedure

This section provides the necessary steps for the assembly of the MMK-1000L with either the BB-1000L or PKM-1000L. It is assumed that the BB-1000L or PKM-1000L has been secured to the stud according to the instructions in the latest revisions of their Installation Guides (Doc. 6060 and Doc. 6061 respectively). It is also assumed that drywall is in place and a rectangular cutout for the controller is made in the drywall.

Complete the steps in the order provided. The only tools or materials required and not supplied are four standard drywall screws, #2 Phillips screwdriver, a level and tools/material to apply drywall joint compound.

CAUTION: Allow an air gap of at least 12 inches (30.48 cm) in the wall cavity above and below the controller for heat dissipation.

NOTE: The illustrations in this procedure show the installation of the MMK-1000L with the PKM-1000L. Even though the illustrations only show the PKM-1000L, they are identical for the BB-1000L.

1. Pass an adjustment plate through the opening and align its two center holes with the top two pins on the PKM-1000L. Verify that the pins on the adjustment plate are not between (facing) the adjustment plate and the PKM-1000L. Refer to the illustration on the following page for visual guidance.

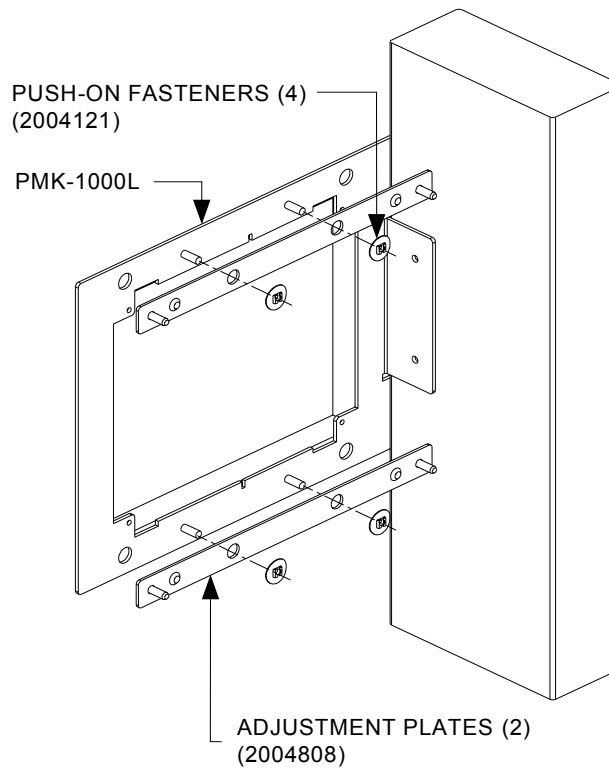
Secure Adjustment Plates to PMK-1000L (or BB-1000L)

2. Slide a push-on fastener over each pin of the PMK-1000L (or BB-1000L) to loosely secure the adjustment plate and the mounting plate. Do not push the push-on fasteners all the way down onto the pins. Slide them on enough to keep the adjustment plate and mounting plate as one adjustment/mounting plate assembly.
3. Use the second adjustment plate and repeat steps 1 and 2 using the lower two PMK-1000L (or BB-1000L) pins.

NOTE: When installing into the PMK-1000L, verify that the 18 AWG bus wire securing the cables for the controller remains attached.

4. Insert the symmetrical mud ring plate into the opening, as shown in the illustration on the following page.

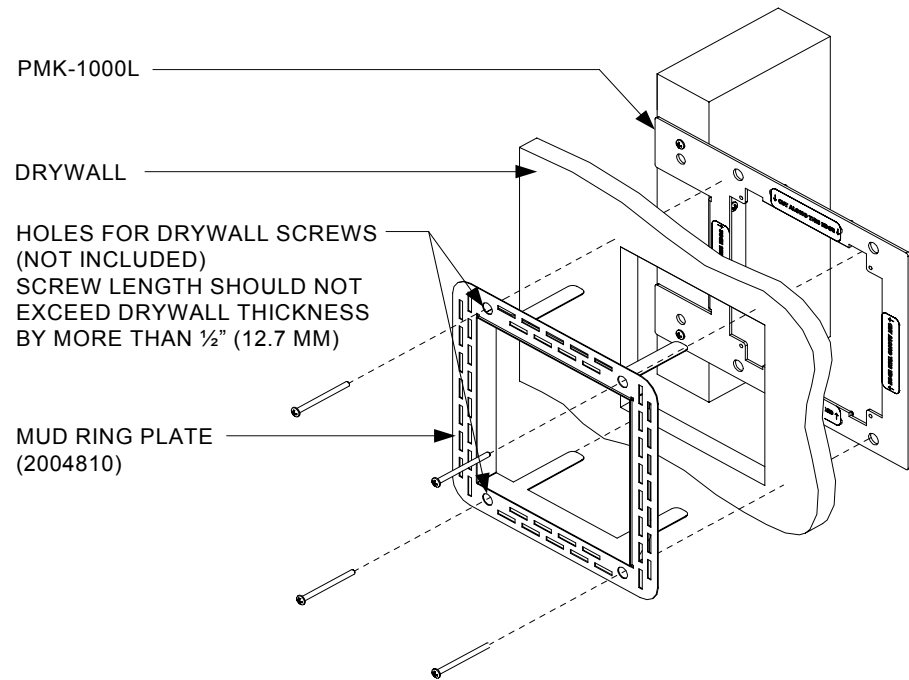
Insert and Secure Mud Ring Plate into PMK-1000L (or BB-1000L)

5. When the mud ring plate is in position, bend the top two flanges of the plate upward and the bottom two flanges downward.
 - If mounting into the PMK-1000L, bend the flanges approximately 90 degrees.
 - If mounting into the BB-1000L, bend the flanges back as far as they can go.
6. Use four standard drywall screws (length should not exceed drywall thickness by more than 1/2 inch) to secure the mud ring plate to the rest of the assembly. The screws pass through the clearance holes in the PMK-1000L (or BB-1000L) and are secured in the extruded holes of the adjustment plates.
7. Verify that the mud ring plate is level.

NOTE: Do not overtighten screws. Doing so may over-dimple or rip the mud ring plate.

8. Use a #2 Phillips screwdriver and tighten the drywall screws by hand so that they slightly dimple into the holes in the mud ring plate.
9. Apply drywall joint compound as needed to finish the cutout. Avoid covering the four tapped mounting holes.
10. Run the necessary cables for the controller and secure them behind the drywall.
11. When dry, the controller can be installed using the four tapped holes in the PMK-1000L. Refer to the latest revision of the APAD Installation and Operations Guide (Doc. 6455) for installation instructions. Refer also to the comprehensive illustration on the following page.

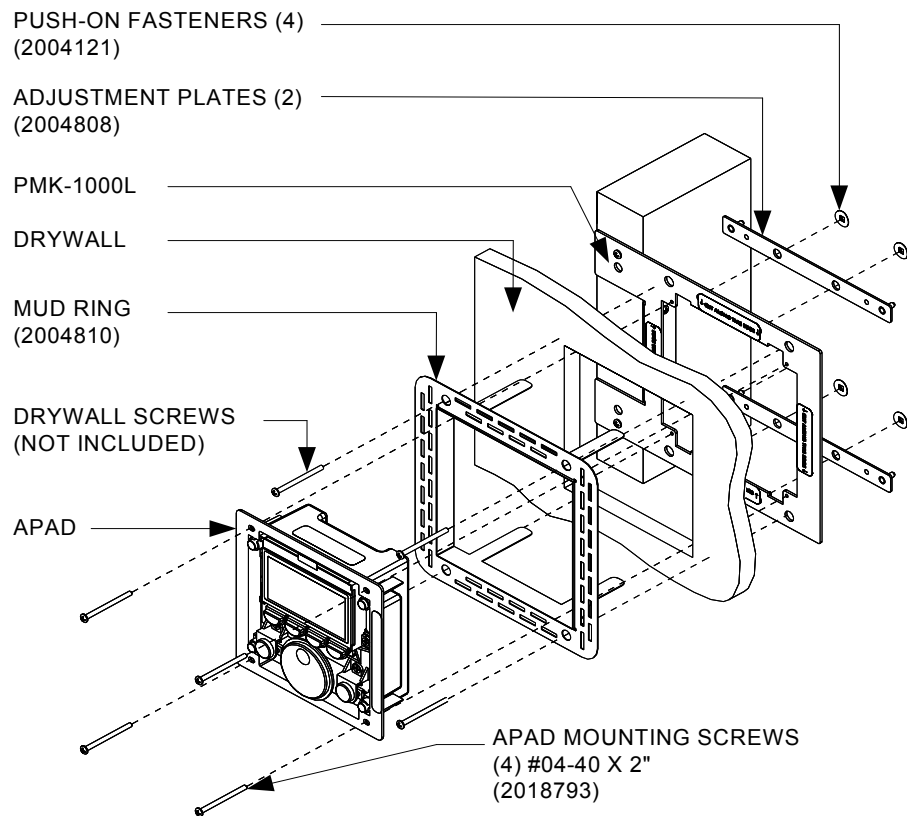
Controller Mounting Using MMK-1000L – Exploded View**WMKM-1000L Procedure**

This section provides the necessary steps for the assembly and installation of the WMKM-1000L into a wall. Review the procedure and complete the steps in the order provided. The only tools or materials required and not supplied are a drywall saw or equivalent, a level, four standard drywall screws, #2 Phillips screwdriver and tools/material to apply drywall joint compound.

CAUTION: Allow an air gap of at least 12 inches (30.48 cm) in the wall cavity above and below the controller for heat dissipation.

1. Insert the two pins on one adjustment plate into the top two outer holes on the mounting plate, as shown in the illustration on the following page.

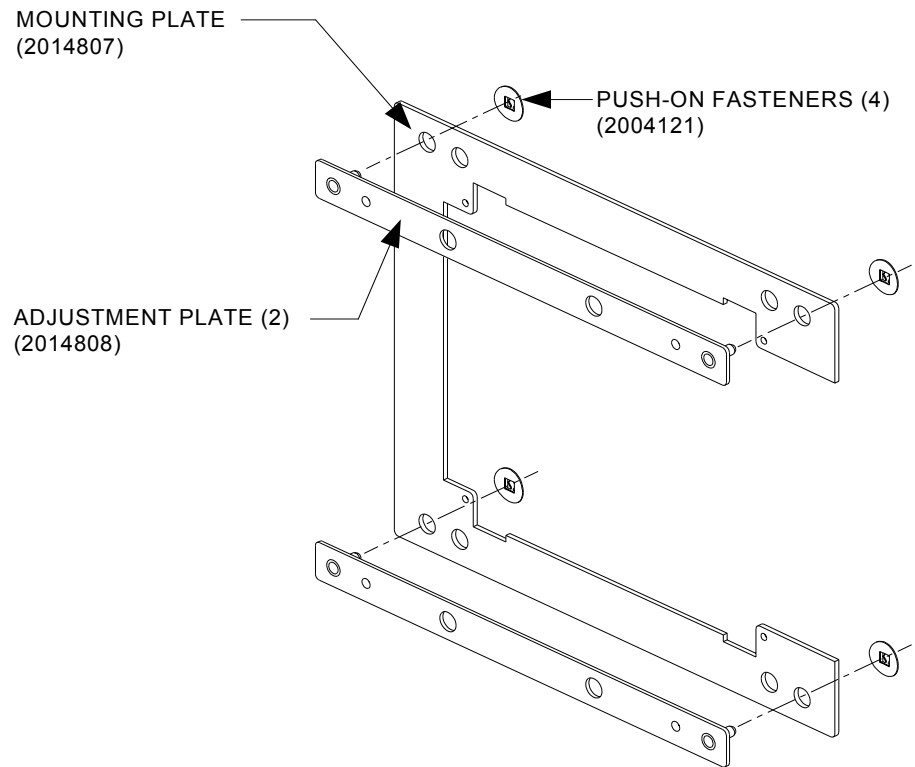
Create the Adjustment/Mounting Plate Assembly

2. Slide a push-on fastener over each pin on the adjustment plate to loosely secure the adjustment plate and the mounting plate. Do not push the push-on fasteners all the way down onto the pins. Slide them on enough to keep the adjustment plate and mounting plate as one adjustment/mounting plate assembly.
3. Use the second adjustment plate and repeat steps 1 and 2 using the lower two pins.
4. Locate an area on the wall that is free of miscellaneous wiring and studs.
5. Make a small hole near the middle of the designated site; verify that the location is suitable.

NOTE: Make the cutout as level as possible. The mounting plate allows for only minor leveling adjustments.

6. Use the drywall saw or equivalent to produce a level, rectangular cutout in the drywall as shown on page 3 or 4.
7. Insert the symmetrical mud ring plate into the opening, as shown in the illustration on the following page.

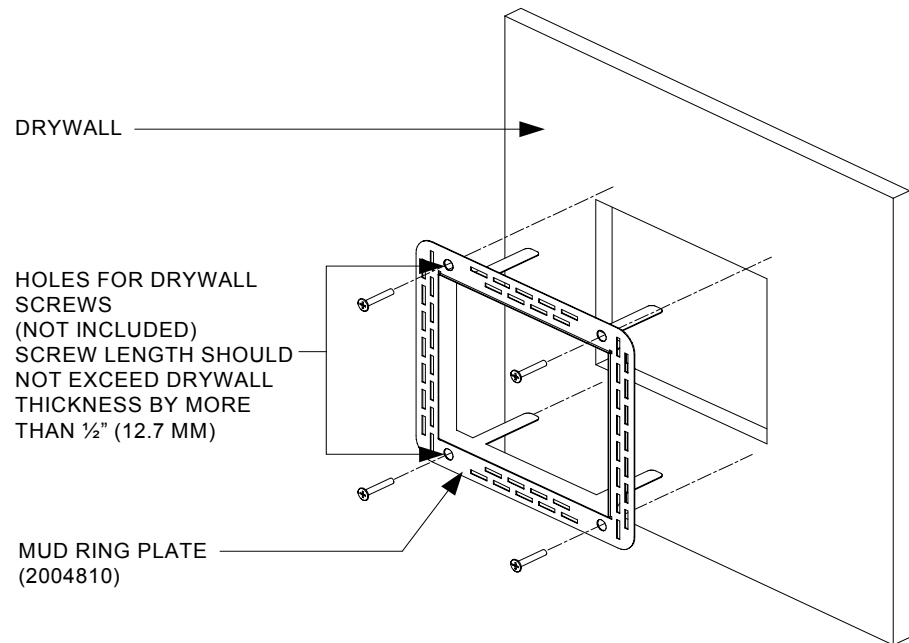
Insert Mud Ring Plate into Opening

8. Carefully pass the adjustment/mounting plate assembly through the opening and rest the assembly against the interior surface of the drywall. Verify that the adjustment plates are between the mounting plate and the drywall.
9. When the adjustment/mounting plate assembly is in position, bend the top two flanges of the mud ring upward (approximately 90 degrees) and the bottom two flanges downward (approximately 90 degrees). Refer to the illustration on the following page.

NOTE: Adjustment/mounting plate assembly will have a slight play; this is normal. It allows for minor adjustments to the entire assembly during installation.

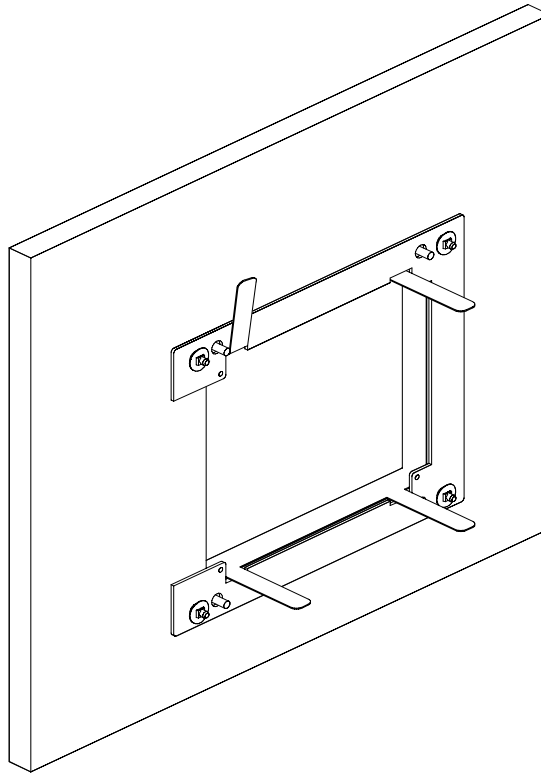
Bend Flanges

10. Use four standard drywall screws (of adequate length) to secure the plate to the adjustment/mounting plate assembly. The screws pass through the clearance holes in the plate and are secured in the extruded holes of the adjustment plates.
11. Verify that the plate is level before tightening.

NOTE: Do not over tighten screws. Doing so may damage the plate.

12. Use a #2 Phillips screwdriver and tighten the drywall screws by hand so that they slightly dimple into the holes in the mud ring plate.
13. Run the necessary cables for the controller and secure them behind the drywall.
14. Apply drywall joint compound as needed to finish the cutout. Avoid covering the four tapped mounting holes.
15. When the joint compound is dry, the controller can be installed using the four tapped holes in the mounting plate. Refer to the latest revision of the APAD Installation and Operations Guide (Doc. 6455) for details. Refer also to the comprehensive illustration on the following page.

Controller Mounting Using WMKM-1000L – Exploded View

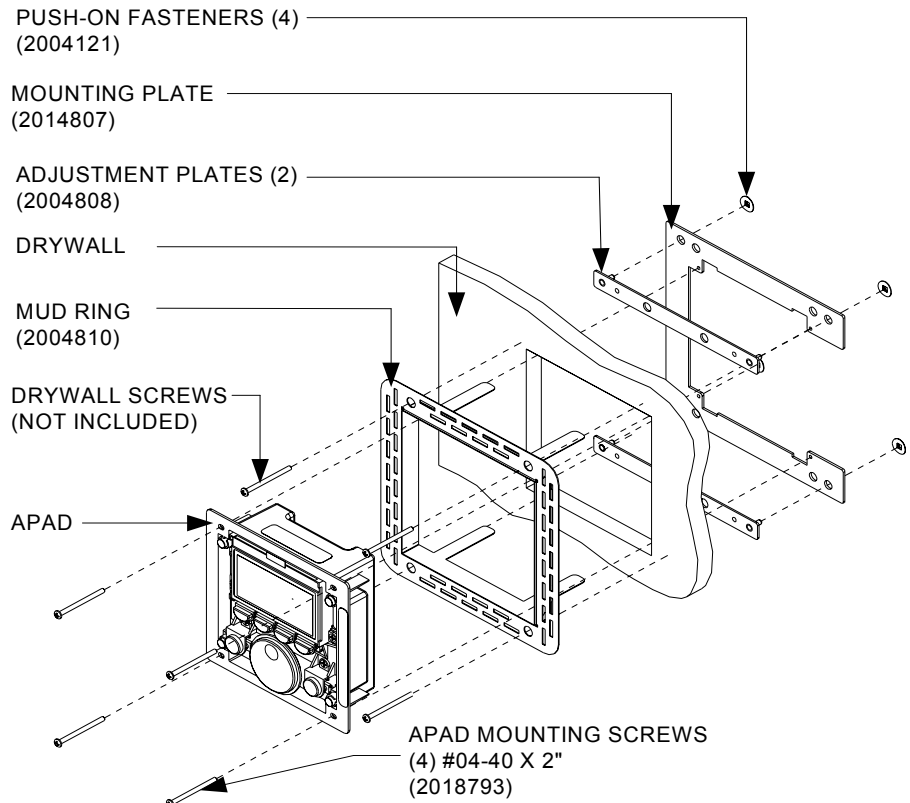

Resources

Industry Compliance

As of the date of manufacture, the MMK-1000L and WMKM-1000L have been tested and found to comply with specifications for CE marking marking.



Reference Documents

The latest version of all documents mentioned within the guide can be obtained from the Crestron website (www.crestron.com/manuals). This link will provide a list of product manuals arranged in alphabetical order by model number.

List of Related Reference Documents

DOCUMENT TITLE
APAD Wall Mount LCD Controller
BB-1000L Back Box
PMK-1000L Pre-Construction Mounting Kit

Further Inquiries

If you cannot locate specific information or have questions after reviewing this guide, please take advantage of Crestron's award winning customer service team by calling the Crestron corporate headquarters at 1-888-CRESTRON [1-888-273-7876]. For assistance in your local time zone, refer to the Crestron website (<http://www.crestron.com/offices>) for a listing of Crestron worldwide offices.

You can also log onto the online help section of the Crestron website (<http://www.crestron.com/onlinehelp>) to ask questions about Crestron products. First-time users will need to establish a user account to fully benefit from all available features.

Future Updates

As Crestron adds improvements to the MMK-1000L or WMKM-1000L, additional information may be made available as manual updates. These updates are solely electronic and serve as intermediary supplements prior to the release of a complete technical documentation revision.

Check the Crestron website periodically for manual update availability and its relevance. Updates are identified as an “Addendum” in the Download column.

Return and Warranty Policies

Merchandise Returns / Repair Service

1. No merchandise may be returned for credit, exchange or service without prior authorization from CRESTRON. To obtain warranty service for CRESTRON products, contact an authorized CRESTRON dealer. Only authorized CRESTRON dealers may contact the factory and request an RMA (Return Merchandise Authorization) number. Enclose a note specifying the nature of the problem, name and phone number of contact person, RMA number and return address.
2. Products may be returned for credit, exchange or service with a CRESTRON Return Merchandise Authorization (RMA) number. Authorized returns must be shipped freight prepaid to CRESTRON, 6 Volvo Drive, Rockleigh, N.J. or its authorized subsidiaries, with RMA number clearly marked on the outside of all cartons. Shipments arriving freight collect or without an RMA number shall be subject to refusal. CRESTRON reserves the right in its sole and absolute discretion to charge a 15% restocking fee plus shipping costs on any products returned with an RMA.
3. Return freight charges following repair of items under warranty shall be paid by CRESTRON, shipping by standard ground carrier. In the event repairs are found to be non-warranty, return freight costs shall be paid by the purchaser.

CRESTRON Limited Warranty

CRESTRON ELECTRONICS, Inc. warrants its products to be free from manufacturing defects in materials and workmanship under normal use for a period of three (3) years from the date of purchase from CRESTRON, with the following exceptions: disk drives and any other moving or rotating mechanical parts, pan/tilt heads and power supplies are covered for a period of one (1) year; touchscreen display and overlay components are covered for 90 days; batteries and incandescent lamps are not covered.

This warranty extends to products purchased directly from CRESTRON or an authorized CRESTRON dealer. Purchasers should inquire of the dealer regarding the nature and extent of the dealer's warranty, if any.

CRESTRON shall not be liable to honor the terms of this warranty if the product has been used in any application other than that for which it was intended or if it has been subjected to misuse, accidental damage, modification or improper installation procedures. Furthermore, this warranty does not cover any product that has had the serial number altered, defaced or removed.

This warranty shall be the sole and exclusive remedy to the original purchaser. In no event shall CRESTRON be liable for incidental or consequential damages of any kind (property or economic damages inclusive) arising from the sale or use of this equipment. CRESTRON is not liable for any claim made by a third party or made by the purchaser for a third party.

CRESTRON shall, at its option, repair or replace any product found defective, without charge for parts or labor. Repaired or replaced equipment and parts supplied under this warranty shall be covered only by the unexpired portion of the warranty.

Except as expressly set forth in this warranty, CRESTRON makes no other warranties, expressed or implied, nor authorizes any other party to offer any warranty, including any implied warranties of merchantability or fitness for a particular purpose. Any implied warranties that may be imposed by law are limited to the terms of this limited warranty. This warranty statement supersedes all previous warranties.

Trademark Information

All brand names, product names, and trademarks are the sole property of their respective owners. Windows is a registered trademark of Microsoft Corporation. Windows95/98/Me/XP/Vista and WindowsNT/2000 are trademarks of Microsoft Corporation.



Crestron Electronics, Inc.
15 Volvo Drive Rockleigh, NJ 07647
Tel: 888.CRESTRON
Fax: 201.767.7576
www.crestron.com

Installation Guide – DOC. 6062A
(2002106)
01.08
Specifications subject to
change without notice.