

# ULTIMATE IC3-AW-SA-BOX-WOOFER-W-T-EACH

Ultimate 3 in. All Weather In-Ceiling Woofer, White Textured, Single



- 6 in. (152 mm) carbon fiber woofer
- IP66 rated for dust and water with weatherized construction
- 44 Hz to 20 kHz ( $\pm 3$  dB) frequency response
- 8 Ohms nominal impedance
- Various square and round trim rings and grilles

The Crestron Ultimate in-ceiling woofer made by Origin Acoustics delivers the pinnacle of performance for demanding residential installations. Weatherized construction allows for use in a shower, sauna, locker room, yacht, and marine applications.

The [ULTIMATE-IC3-AW-SA-BOX-WOOFER-W-T-EACH](#) includes mounting hardware, trim-ring kit, grilles and installation hardware.

The ULTIMATE-IC3-AW-SA-BOX-WOOFER-W-T-EACH is part of the [ULTIMATE IC3-SA-WOOFER/TWEETER-W-T-KIT](#) that includes [ULTIMATE IC3-AW-SA-TWEETER-EACH](#) as well.

In the pre-construction phase, just the ULTIMATE-IC3-AW-SA-BOX-WOOFER-W-T-EACH can be installed, and once construction is finished, the ULTIMATE IC3-AW-SA-TWEETER-EACH can be installed to complete the speaker setup.

The installation process is simplified with built-in rails that secure the woofer enclosure directly to the ceiling joists, ensuring a level and secure fit.

## Specifications

### ULTIMATE IC3-AW-SA-BOX-WOOFER-W-T-EACH

<b>Woofer</b>	6 in. (162 mm) carbon fiber
<b>Crossover</b>	Custom 2-way passive
<b>Crossover Point</b>	200 Hz
<b>Impedance</b>	8 Ohms nominal
<b>Frequency Response</b>	44 Hz to 20 kHz ( $\pm 3$ dB)
<b>Coverage</b>	100° conical
<b>Sensitivity</b>	82 dB @ 1 W/1 M
<b>Input</b>	2-pin pluggable screw terminals
<b>Max Wire Size</b>	12 AWG (4 mm <sup>2</sup> )
<b>Enclosure Material</b>	Cast Aluminum
<b>Mounting</b>	Overlapping formed steel straps Adjustable from 14.25 in. (362 mm) to 24 in. (610 mm).
<b>Splash Resistance</b>	IP66 rated for water
<b>Height</b>	14 in. (356 mm)
<b>Width</b>	8 in. (203 mm)
<b>Depth</b>	6.67 in. (169 mm)
<b>Weight</b>	11.5 lb (5.21 kg)

### Square Trim Rings Dimension

<b>Flush</b>	Diameter: 3.94 in. (100 mm)
<b>Invisible</b>	External Diameter: 5.12 in. (130 mm) Internal Diameter: 3.94 in. (100 mm)
<b>Flanged</b>	External Diameter: 4.88 in. (124 mm) Internal Diameter: 3.94 in. (100 mm)

### Round Trim Rings Dimension

<b>Flush</b>	Diameter: 3.74 in. (95 mm)
<b>Invisible</b>	External Diameter: 4.92 in. (125 mm) Internal Diameter: 3.74 in. (95 mm)
<b>Flanged</b>	External Diameter: 4.69 in. (119 mm) Internal Diameter: 3.74 in. (95 mm)

### Environmental

<b>Temperature</b>	4° to 176°F (-15.5° to 80°C)
<b>Humidity</b>	10% to 95% RH (non-condensing)

# ULTIMATE IC3-AW-SA-BOX-WOOFER-W-T-EACH

Ultimate 3 in. All Weather In-Ceiling Woofer, White Textured, Single

## Compliance

---

### Regulatory Model: M202145001

CE, Intertek® Listed for US & Canada, FCC Part 15 Class B digital device

To search for product certificates, refer to [support.crestron.com/app/certificates](https://support.crestron.com/app/certificates).

## Model

### ULTIMATE IC3-AW-SA-BOX-WOOFER-W-T-EACH

Ultimate 3 in. All Weather In-Ceiling Woofer, White Textured, Single

This product may be purchased from select authorized Crestron dealers and distributors. To find a dealer or distributor, please contact the Crestron sales representative for your area. A list of sales representatives is available online at [www.crestron.com/How-To-Buy/Find-a-Representative](https://www.crestron.com/How-To-Buy/Find-a-Representative) or contact us for additional information by visiting [www.crestron.com/contact/our-locations](https://www.crestron.com/contact/our-locations) for your local contact.

The original language version of this document is U.S. English. All other languages are a translation of the original document.

The product warranty can be found at [www.crestron.com/warranty](https://www.crestron.com/warranty).

The specific patents that cover Crestron products are listed online at [www.crestron.com/legal/patents](https://www.crestron.com/legal/patents).

Certain Crestron products contain open source software. For specific information, please visit [www.crestron.com/opensource](https://www.crestron.com/opensource).

Crestron and the Crestron logo are either trademarks or registered trademarks of Crestron Electronics, Inc. in the United States and/or other countries. Intertek is either a trademark or registered trademark of Intertek Group in the United States and/or other countries. Origin Acoustics is either a trademark or a registered trademark of Origin Acoustics, Inc. in the United States and/or other countries. Other trademarks, registered trademarks, and trade names may be used in this document to refer to either the entities claiming the marks and names or their products. Crestron disclaims any proprietary interest in the marks and names of others. Crestron is not responsible for errors in typography or photography.

Specifications are subject to change without notice.

©2023 Crestron Electronics, Inc.

Rev 05/18/23

# ULTIMATE IC3-AW-SA-BOX-WOOFER-W-T-EACH

Ultimate 3 in. All Weather In-Ceiling Woofer, White Textured, Single

## ULTIMATE-IC3-AW-SA-BOX-WOOFER-W-T-EACH

Adjustable Bracket Length

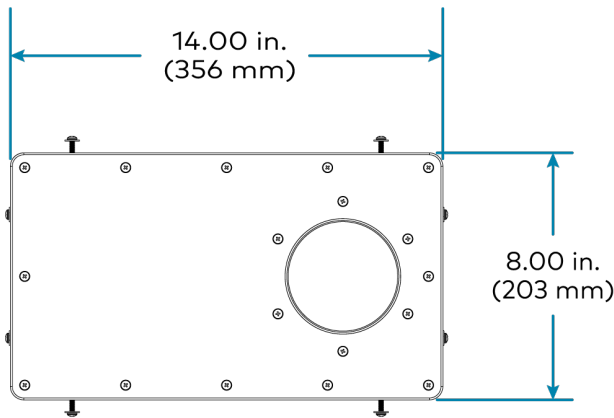
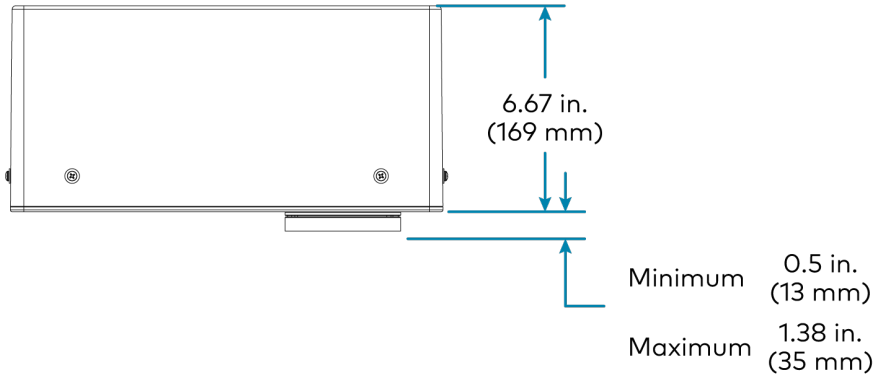
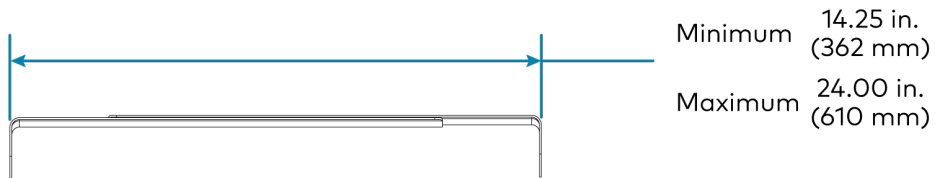

# ULTIMATE IC3-AW-SA-BOX-WOOFER-W-T-EACH

Ultimate 3 in. All Weather In-Ceiling Woofer, White Textured, Single

## Square Trim Rings

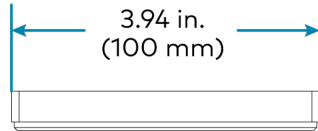

Flush

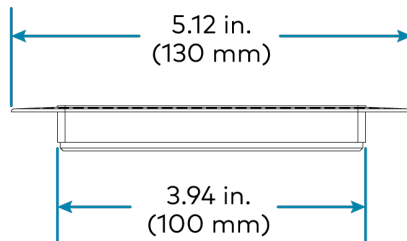
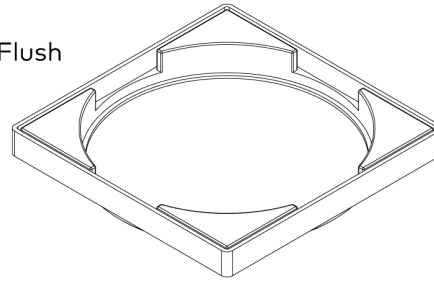

Invisible

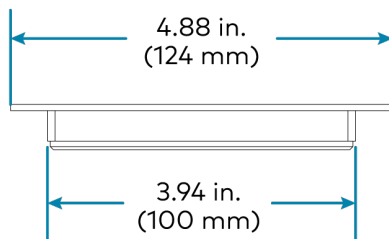
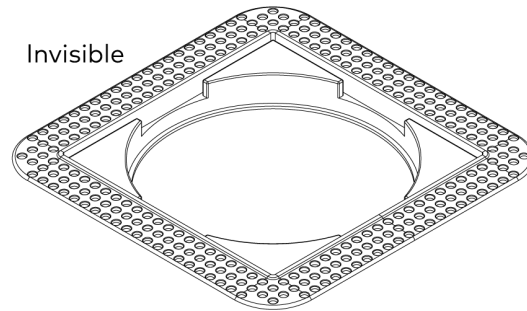

Flanged

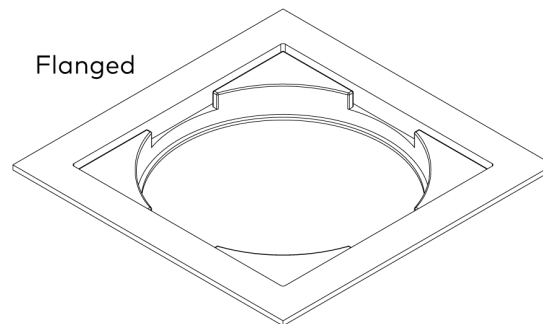

# ULTIMATE IC3-AW-SA-BOX-WOOFER-W-T-EACH

Ultimate 3 in. All Weather In-Ceiling Woofer, White Textured, Single

## Round Trim Rings

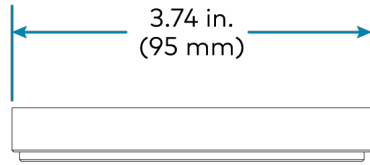

Flush

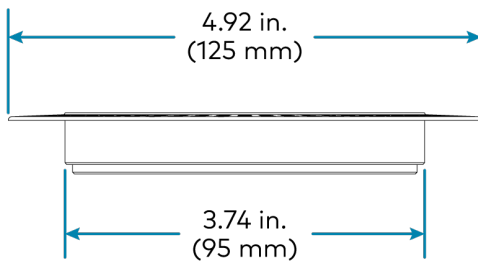
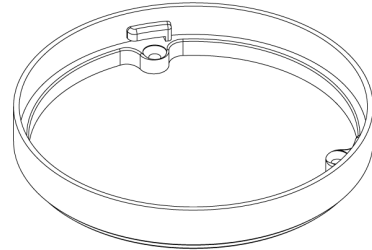

Invisible

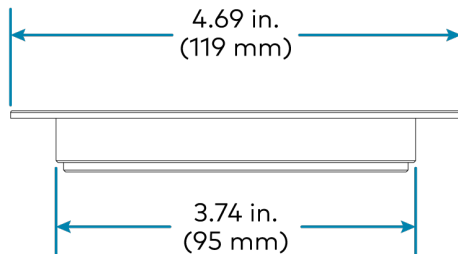
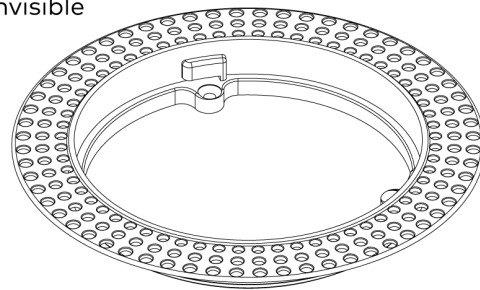

Flanged

