



Description

The Crestron® ZUMMESH-OL-PHOTOCELL-BATT is an open-loop photocell designed to monitor natural daylight levels from windows in a room. It communicates wirelessly with Züm™ load controllers to automatically adjust their dimming levels according to the amount of natural daylight in the room.

Additional Resources

Visit the product page on the Crestron website (www.crestron.com) for additional information and the latest firmware updates. Use a QR reader application on your mobile device to scan the QR image.



Züm Overview

A Züm space consists of one space, such as a board room or conference room, that is equipped with Züm mesh devices. The Züm mesh devices (i.e., dimmers, switches, keypads, and sensors) in the space provide control and communicate directly with each other without the need for a centralized gateway or processor.

If expanded functionality of the Züm space is desired, a ZUMMESH-NETBRIDGE (not included) can be added which provides centralized control and monitoring from a Crestron control system (not included).

NOTE: The ZUMMESH-NETBRIDGE requires a compatible J-box device (not included) to provide power.

Installation

To install the ZUMMESH-OL-PHOTOCELL-BATT, the mounting location must be determined, the base must be mounted to the ceiling, the batteries must be inserted, and the sensor must be secured to the base.

NOTE: Observe the following points:

- Install and use this product in accordance with appropriate electrical codes and regulations.
- Mount sensors on a vibration-free surface.

Determine the Mounting Location

The ZUMMESH-OL-PHOTOCELL-BATT must face a window. Mount the device approximately 4 to 6 feet (1.22 to 1.83 meters) away from the window. The optimum viewing angle for the sensor is 35°.

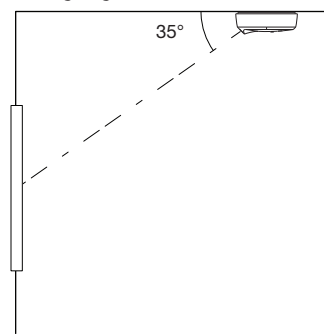

Mount the Base

When mounting the base, ensure that the arrow on the base, shown below, points toward the desired window.

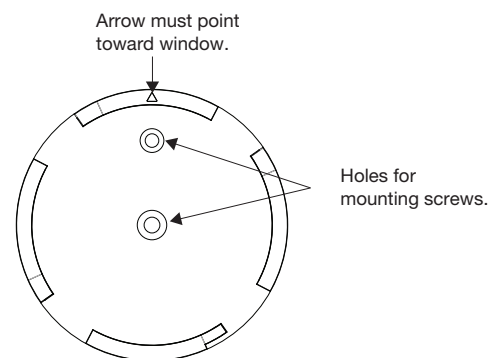

Mount the base to the drywall or drop ceiling using the provided anchors.

1. Determine the proper orientation for the ZUMMESH-OL-PHOTOCELL-BATT.
2. Hold the base on the mounting surface, and use the holes for the mounting screws to mark the screw locations.
3. Using a 1/4 in drill bit, drill a pilot hole for the small anchor, and insert the small anchor into the pilot hole.

4. Using a #2 or #3 Phillips screwdriver, push the self-tapping anchor into the surface of the drywall until the cutting blades penetrate the surface. Using gentle forward pressure, rotate the anchor until the collar sets flush to the surface of the ceiling.
5. Secure the base to the mounting surface using the two supplied screws.

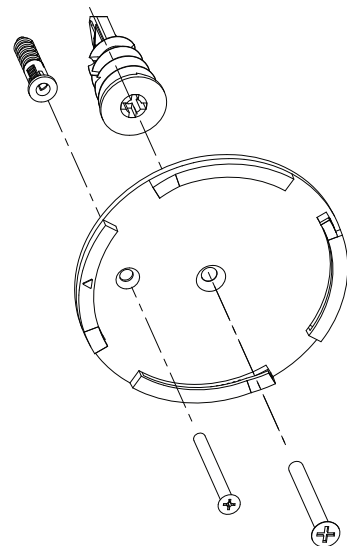

Insert the Batteries

Insert the batteries into the sensor according to the orientation indicated on the device.

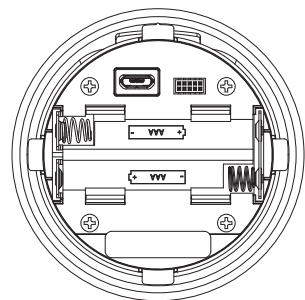

Secure the Sensor to the Base

To secure the sensor to the base, place the sensor on the base and then rotate the sensor clockwise to secure it.

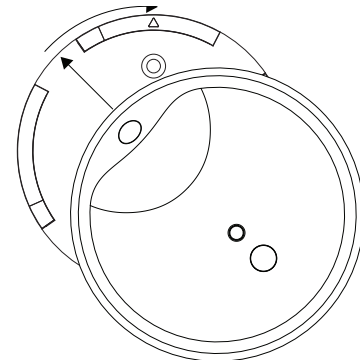

The sensor can rotate up to 40° along the base after it is mounted. Rotate the sensor to ensure that it points at the window.

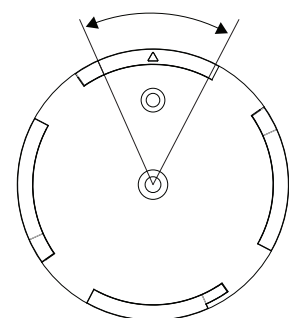

How to Set Up a Züm Space and Add Züm Devices

Once all devices are physically installed in a board room or conference space, a new Züm space can be created and devices added.

NOTE: Only set up one Züm space at a time.

NOTE: For simplified setup of a Züm space, use the Züm app on a mobile device.

Step 1 Create a New Züm Space

Creating a Züm space defines the area where the devices are located, such as a board room or conference room. A Züm space is created with a keypad, dimmer or switch, a J-box device, or an AV Bridge.

NOTE: Creating a Züm space can only be performed by one device in the space.

NOTE: A Züm space cannot be created from a battery-powered keypad.

To create a new Züm space using a keypad, dimmer, or switch:

1. Press the bottom button 5 times.
2. Press and hold the button until the LED on the device lights (about 10 seconds). After approximately 3 seconds, the device LED begins slowly flashing. This indicates that the Züm space is now created and in Joining mode, allowing you to add devices.

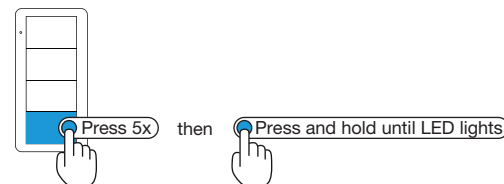

To create a new Züm space using a J-box device or an AV Bridge:

1. Press the **Setup** button 5 times.
2. Press and hold the **Setup** button until the LED on the device lights (about 10 seconds). After approximately 3 seconds, the device LED begins slowly flashing. This indicates that the Züm space is now created and in Joining mode, allowing you to add devices.

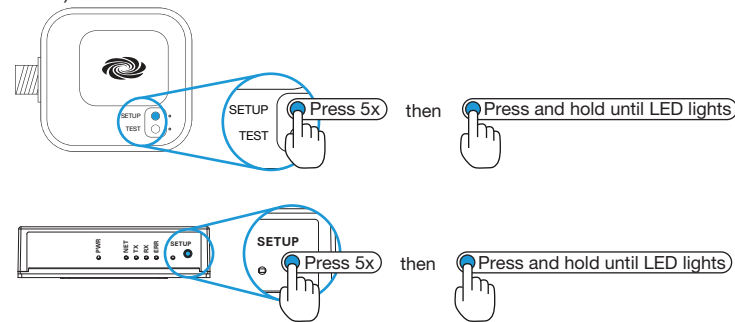

NOTE: The device that is used to create the Züm space is automatically added to the space and does not need to be added in Step 2.

Step 2 Add the Photocell to the Züm Space

After a new Züm space is created, add the ZUMMESH-OL-PHOTOCELL-BATT while the space is in Joining mode.

NOTE: A Züm mesh device can belong to only one space.

NOTE: Joining mode ends automatically after 4 minutes.

To add the ZUMMESH-OL-PHOTOCELL-BATT:

1. Press the setup button 3 times.
2. Press and hold the button until the LED on the device lights (up to 10 seconds) to indicate that it has joined the space.

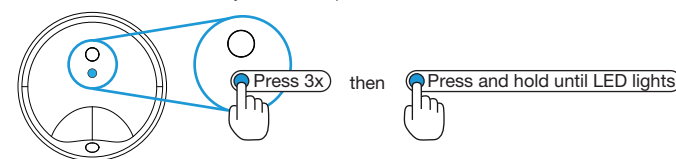

Step 3 Complete Züm Space Setup

To finish creating a Züm space, press any button on a device that is part of the Züm space to exit Joining mode.

Add the Photocell to an Existing Züm Space

Add the ZUMMESH-OL-PHOTOCELL-BATT to an existing Züm space by placing the Züm space in Joining mode.

Add the ZUMMESH-OL-PHOTOCELL-BATT using a keypad, dimmer, or switch:

1. Enter Joining mode.
 - a. Press and hold both the top and bottom buttons until the LED lights (about 5 seconds).
 - b. Press the top button once.
 - c. Press the bottom button once. The LEDs on all devices in the space (except battery powered devices) flash slowly to indicate that the devices are part of the space and that the space is in Joining mode.

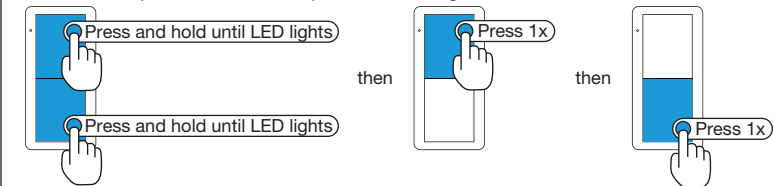

2. Add the ZUMMESH-OL-PHOTOCELL-BATT.
 - a. Press the setup button 3 times.
 - b. Press and hold the button until the LED on the device lights (up to 10 seconds) to indicate that it has joined the space.

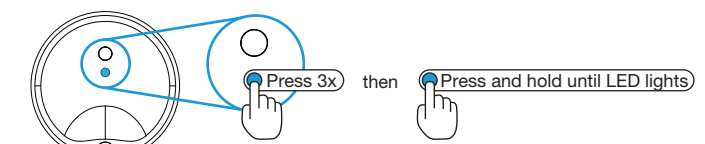

3. Press any button on a device that is part of the Züm space to exit Joining mode.

Add the ZUMMESH-OL-PHOTOCELL-BATT using a J-box device:

1. Enter Joining mode.
 - a. Press the **SETUP** button 2 times.
 - b. Press the **TEST** button once. The LEDs on all devices in the space (except battery powered devices) flash slowly to indicate that the devices are part of the space and that the space is in Joining mode.

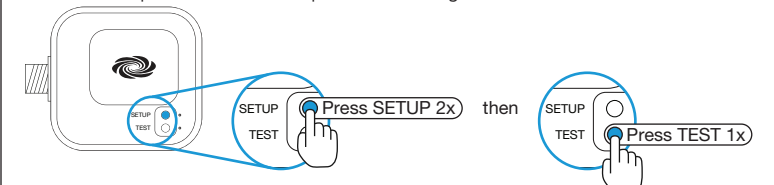

2. Add the ZUMMESH-OL-PHOTOCELL-BATT.
 - a. Press the setup button 3 times.
 - b. Press and hold the button until the LED on the device lights (up to 10 seconds) to indicate that it has joined the space.

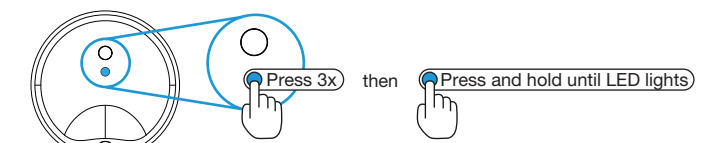

3. Press any button on a device that is part of the Züm space to exit Joining mode.

Calibrate and Test the Daylight Sensor

To enable daylight harvesting, calibrate and then test the daylight sensor after all devices are installed and powered in the Züm space.

NOTE: When setting up the daylight sensor, consider the following:

- Only dimmers are capable of adjusting load levels that are driven by daylight sensor readings.
- Daylighting only operates when Scene 1 is enabled.
- Calibrate the daylight sensor during the day when the sun is bright. Avoid light fluctuations caused by clouds that are rapidly exposing and hiding the sun.
- Do not stand between the daylight sensor and the windows. Doing so affects the readings and can result in poor calibration settings.

Calibrate the Daylight Sensor:

1. Adjust the lights in the room to the desired levels.

NOTE: Take the natural daylight levels into consideration when setting the load levels. Each dimmer can be set to a different level. Typically, lights closer to windows are dimmed more than lights away from windows.

NOTE: To prevent daylighting from affecting a dimmer, set the lights on the dimmer to brighter than scene 1.

2. Press and hold the button for 5 seconds to initiate the daylight calibration process. The LED flashes red to indicate that the calibration process is in progress; this process takes 60 seconds. During the calibration process, the lights cycle on and off. After the daylight calibration process is complete, the room enters Test mode. Refer to "Test Mode" for details.

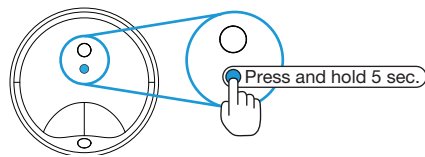

Test Mode

Test mode is used to verify that the settings stored during calibration are correct. Changes to the amount of light in the space results in rapid light level adjustments.

NOTE: During normal operation, the light levels are adjusted slowly so that they are not seen by the occupants in the room.

To enter Test mode, press and hold the button for 2 seconds. When in Test mode, the LED flashes twice, pauses, then repeats. The device exits Test mode after 2 minutes.

To verify the daylight sensor settings, close the blinds or block the cover of the sensor to reduce the amount of light in the space; the light level will increase. Open the blinds or unblock the cover of the sensor to increase the amount of light in the space; the light level will decrease.

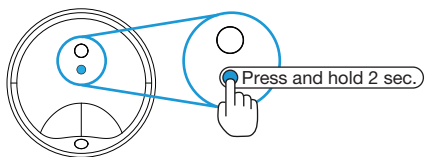

Factory Reset

Perform a factory reset when the device is removed from the network or to remove the configuration settings. The device must also be factory reset if the device is being moved to a different system.

NOTE: New-in-box devices do not need to be factory reset before joining a system.

To factory reset the daylight sensor, press and hold the button until the LED flashes rapidly 3 times (about 10 seconds), then release the button.

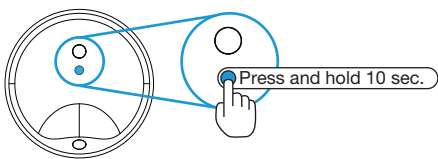

Replace the Batteries

Use the following procedure to replace the batteries in the sensor.

CAUTION: The batteries used in this device may present a risk of fire or chemical burn if mistreated. Do not recharge, disassemble, heat above 212 °F (100 °C), or incinerate. Replace with Energizer® L92 Ultimate Lithium AAA batteries only. Use of other batteries may present a risk of fire or explosion.

1. Rotate the sensor counterclockwise to remove the sensor from the base.
2. Remove the batteries from the sensor.
3. Replace the batteries in the sensor.
4. Rotate the sensor clockwise onto the installed base until it is secured in place.

NOTE: Dispose of a used batteries promptly. Keep away from children. Do not disassemble and do not dispose of in fire.

Specifications

The specifications for the ZUMMESH-OL-PHOTOCELL-BATT are listed below.

SPECIFICATION	DETAILS
Power	
Battery	(2) AAA 1.5 Volt lithium disposable batteries (included)
Battery Life	10 years under normal operating conditions
Sensing	
Light Sensitivity	0 to 65,535 lux (0 to 6,089 foot-candles)
Angle and Distance	35° optimum sensing angle at 4 to 6 feet (1.22 to 1.83 meters) from window
Environmental	
Temperature	32° to 104 °F (0° to 40 °C)
Humidity	10% to 95% RH (noncondensing)

This product is Listed to applicable UL® Standards and requirements tested by Underwriters Laboratories Inc.

Ce produit est homologué selon les normes et les exigences UL applicables par Underwriters Laboratories Inc.



As of the date of manufacture, the product has been tested and found to comply with specifications for CE marking.



Federal Communications Commission (FCC) Compliance Statement

This device complies with part 15 of the FCC Rules. Operation is subject to the following conditions:(1) This device may not cause harmful interference and (2) this device must accept any interference received, including interference that may cause undesired operation.

CAUTION: Changes or modifications not expressly approved by the manufacturer responsible for compliance could void the user's authority to operate the equipment.

NOTE: This equipment has been tested and found to comply with the limits for a Class B digital device, pursuant to part 15 of the FCC Rules. These limits are designed to provide reasonable protection against harmful interference in a residential installation. This equipment generates,

uses and can radiate radio frequency energy and, if not installed and used in accordance with the instructions, may cause harmful interference to radio communications. However, there is no guarantee that interference will not occur in a particular installation. If this equipment does cause harmful interference to radio or television reception, which can be determined by turning the equipment off and on, the user is encouraged to try to correct the interference by one or more of the following measures:

- Reorient or relocate the receiving antenna.
- Increase the separation between the equipment and receiver.
- Connect the equipment into an outlet on a circuit different from that to which the receiver is connected.
- Consult the dealer or an experienced radio/TV technician for help.

Industry Canada (IC) Compliance Statement

This device complies with Industry Canada license-exempt RSS standard(s). Operation is subject to the following two conditions: (1) this device may not cause interference and (2) this device must accept any interference, including interference that may cause undesired operation of the device.

Under Industry Canada regulations, this radio transmitter may only operate using an antenna of a type and maximum (or lesser) gain approved for the transmitter by Industry Canada. To

reduce potential radio interference to other users, the antenna type and its gain should be so chosen that the equivalent isotropically radiated power (e.i.r.p.) is not more than that necessary for successful communication.

Industrie Canada (IC) Déclaration de conformité

Le présent appareil est conforme aux CNR d'Industrie Canada applicables aux appareils radio exempts de licence. L'exploitation est autorisée aux deux conditions suivantes: (1) l'appareil ne doit pas produire de brouillage, et (2) l'utilisateur de l'appareil doit accepter tout brouillage radioélectrique subi, même si le brouillage est susceptible d'en compromettre le fonctionnement.

Conformément à la réglementation d'Industrie Canada, le présent émetteur radio peut fonctionner avec une antenne d'un type et d'un gain maximal (ou inférieur) approuvé pour l'émetteur par Industrie Canada. Dans le but de réduire les risques de brouillage radioélectrique à l'intention des autres utilisateurs, il faut choisir le type d'antenne et son gain de sorte que la puissance isotrope rayonnée équivalente (p.i.r.e.) ne dépasse pas l'intensité nécessaire à l'établissement d'une communication satisfaisante.

To satisfy RF exposure requirements, this device and its antenna must operate with a separation distance of at least 20 centimeters from all persons and must not be collocated or operating in conjunction with any other antenna or transmitter.

The product warranty can be found at www.crestron.com/warranty.

The specific patents that cover Crestron products are listed at www.crestron.com/legal/patents.

Certain Crestron products contain open source software. For specific information, please visit www.crestron.com/opensource.

Crestron, the Crestron logo, and Züm are either trademarks or registered trademarks of Crestron Electronics, Inc. in the United States and/or other countries. UL and the UL logo are either trademarks or registered trademarks of Underwriters Laboratories, Inc. in the United States and/or other countries. Other trademarks, registered trademarks, and trade names may be used in this document to refer to either the entities claiming the marks and names or their products. Crestron disclaims any proprietary interest in the marks and names of others. Crestron is not responsible for errors in typography or photography.

This document was written by the Technical Publications department at Crestron.

©2018 Crestron Electronics, Inc.

Crestron Electronics, Inc.
15 Volvo Drive, Rockleigh, NJ 07647
Tel: 888.CRESTRON
Fax: 201.767.7576
www.crestron.com

Installation Guide - DOC. 7866B

(2047762)

04.18

Specifications subject to change without notice.