



Description

The Crestron® FT2A-CHGR-USBA/C module provides one USB Type-A port and one USB Type-C™ port for charging USB devices within an electrically-powered FT2 FlipTop™ system.

Additional Resources

Visit the product page on the Crestron website (www.crestron.com) for additional information and the latest firmware updates. Use a QR reader application on your mobile device to scan the QR image.



Overview

Each FT2A-CHGR-USBA/C module provides one USB Type-A port and one USB Type-C port for charging USB devices via cables with USB-A connectors and USB-C™ connectors, respectively. The charging behavior for an FT2A-CHGR-USBA/C module differs depending on the type(s) of USB connections made:

- If a USB device is connected to the USB-A port and the USB-C port is not used, full 12 W charging rapidly charges the device.
- If a USB device is connected to the USB-C port and the USB-A port is not used, full USB-C charging rapidly charges the device at up to 32.5 W maximum power.

NOTE: The rapidity of the USB-C charge varies depending on the device and its power level.

- If devices are connected to both the USB-A port and the USB-C port, the USB-C device rapidly charges while the USB-A device charges at a 2.5 W limit.

The FT2A-CHGR-USBA/C module is 0.98" x 1.97" (25 x 50 mm), and it requires one empty module space in the FT2-ELEC for installation. The FT2A-CHGR-USBA/C module also features a backlit LED icon that lights when the module is connected to an FT2 power bus.

FT2A-CHGR-USBA/C Diagram

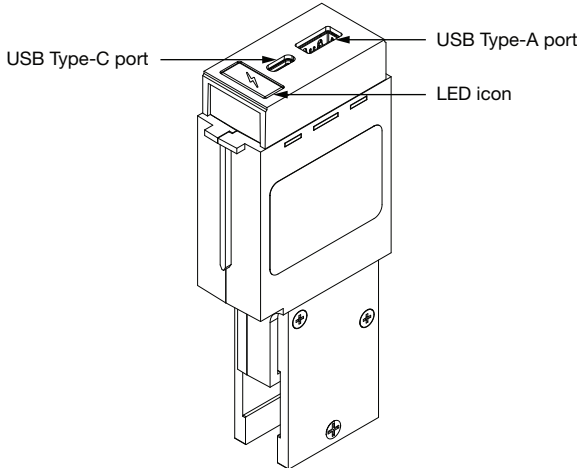

Installation

NOTE: The FT2A-CHGR-USBA/C module is only compatible with the FT2-ELEC series.

NOTE: No more than two FT2A-CHGR-USBA/C modules can be installed in an FT2-ELEC:

- If two FT2A-CHGR-USBA/C modules are installed in an FT2-ELEC, each module must be positioned in a different module row.
- Each module row containing a FT2A-CHGR-USBA/C module must be powered by its own power supply. For more information on installing power supplies, refer to the FT2-ELEC DO Guide (Doc. 8216) at www.crestron.com/manuals.

Use the following procedure to install the FT2A-CHGR-USBA/C module into an FT2-ELEC assembly. If the FT2A-CHGR-USBA/C module is being installed as part of a new FT2-ELEC installation, skip ahead to step 3.

1. Remove the magnetic bezel from the FT2-ELEC assembly by grasping the inside of the bezel and by firmly pulling it up and away from the assembly until the magnetic hold is broken.
2. Unscrew and remove the two locking bars on either side of the module row needed for installation. For example, if installing the FT2-CHGR-USBA/C module in the bottom row of an FT2-700, remove the middle and bottom locking bars.

Removing the Locking Bars

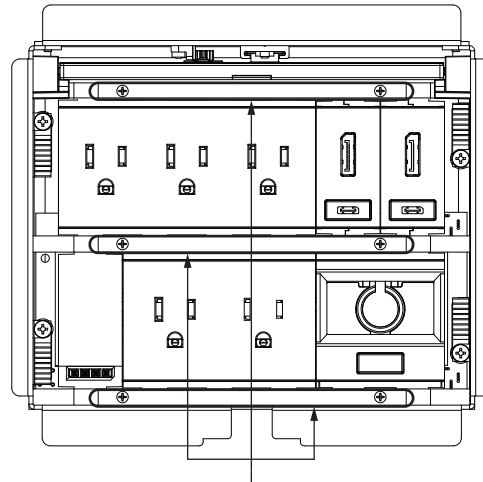

Locking bars (3)

3. Orient the module so that the module's LED icon is facing toward the front of the FT2-ELEC assembly as shown in the following illustration.

Positioning the FT2A-CHGR-USBA/C

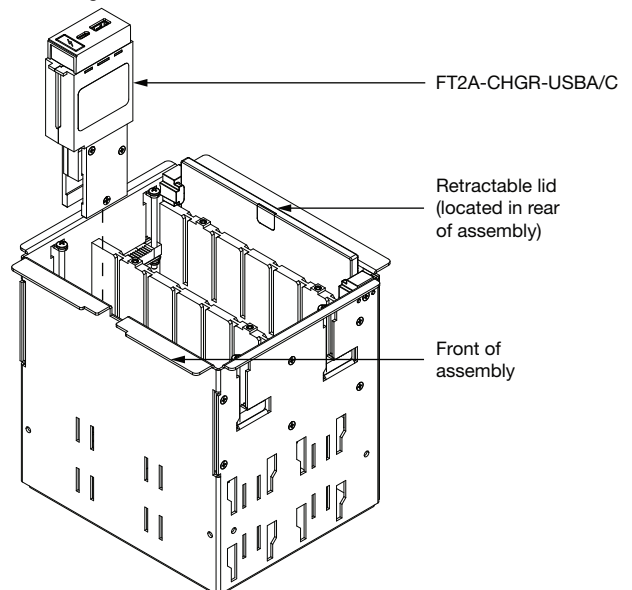

4. Push the top of the module down into the appropriate module spaces in the FT2-ELEC assembly so that the module slides into place. Use the guide ribs on the front and rear of each module to help position the module in the assembly.

Installing the FT2A-CHGR-USBA/C into the FT2-ELEC Assembly - Overhead View

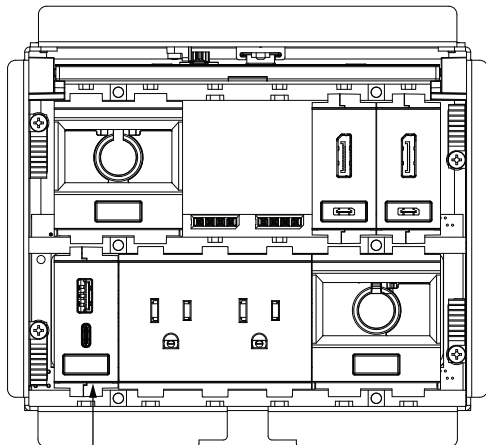

FT2A-CHGR-USBA/C

5. Once all modules and plates are installed and level with their surroundings, place the removed locking bars back into position so that the screws on either side engage the screw holes in the assembly. Then, hand tighten the two screws attached to the sides of each bar until the bars are secured to the assembly.

CAUTION: To avoid stripping the screws on the locking bars, hand tighten the screws using a manual screwdriver only.

6. Hold the magnetic bezel over the assembly so that the lid retraction button on the bezel is aligned with the front of the assembly. Then, lower the bezel onto the assembly so that the lowered retractable lid fits inside the rear opening in the bezel and the magnets snap into place against the assembly. Refer to the illustration below.

FT2 with FT2A-CHGR-USBA/C and Bezel Installed

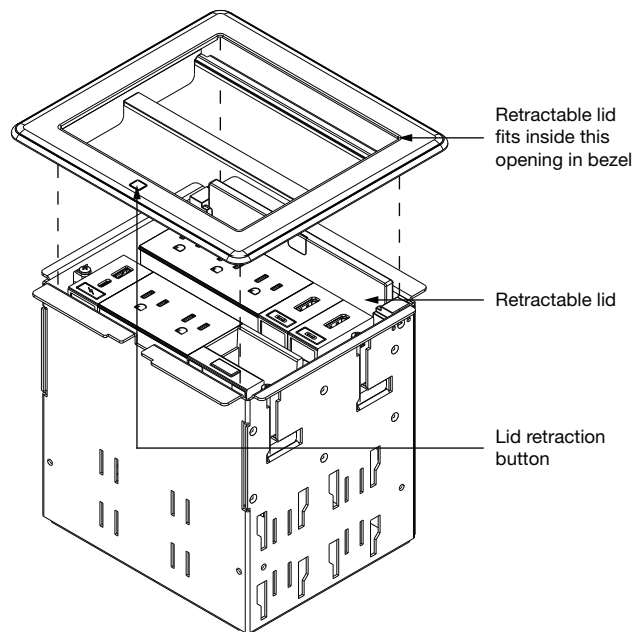

As of the date of manufacture, the product has been tested and found to comply with specifications for CE marking.



This product is Listed to applicable UL® Standards and requirements tested by Underwriters Laboratories Inc.

Ce produit est homologué selon les normes et les exigences UL applicables par Underwriters Laboratories Inc.



Federal Communications Commission (FCC) Compliance Statement

This device complies with part 15 of the FCC Rules. Operation is subject to the following conditions: (1) This device may not cause harmful interference and (2) this device must accept any interference received, including interference that may cause undesired operation.

CAUTION: Changes or modifications not expressly approved by the manufacturer responsible for compliance could void the user's authority to operate the equipment.

NOTE: This equipment has been tested and found to comply with the limits for a Class B digital device, pursuant to part 15 of the FCC Rules. These limits are designed to provide reasonable protection against harmful interference in a residential installation. This equipment generates, uses and can radiate radio frequency energy and, if not installed and used in accordance with the instructions, may cause harmful interference to radio communications. However, there is no guarantee that interference will not occur in a particular installation. If this equipment does cause harmful interference to radio or television reception, which can be determined by turning the equipment off and on, the user is encouraged to try to correct the interference by one or more of the following measures:

- Reorient or relocate the receiving antenna.
- Increase the separation between the equipment and receiver.
- Connect the equipment into an outlet on a circuit different from that to which the receiver is connected.
- Consult the dealer or an experienced radio/TV technician for help.

Industry Canada (IC) Compliance Statement

CAN ICES-3 (B)/NMB-3(B)

The product warranty can be found at www.crestron.com/warranty.

The specific patents that cover Crestron products are listed at www.crestron.com/legal/patents.

Certain Crestron products contain open source software. For specific information, please visit www.crestron.com/opensource.

Crestron, the Crestron logo, and FlipTop are either trademarks or registered trademarks of Crestron Electronics, Inc. in the United States and/or other countries. UL and the UL logo are either trademarks or registered trademarks of Underwriters Laboratories, Inc. in the United States and/or other countries. USB-C and USB Type-C are either trademarks or registered trademarks of the USB Implementers Forum in the United States and/or other countries. Other trademarks, registered trademarks, and trade names may be used in this document to refer to either the entities claiming the marks and names or their products. Crestron disclaims any proprietary interest in the marks and names of others. Crestron is not responsible for errors in typography or photography.

This document was written by the Technical Publications department at Crestron.

©2017 Crestron Electronics, Inc.

Crestron Electronics, Inc.
15 Volvo Drive, Rockleigh, NJ 07647
Tel: 888.CRESTRON
Fax: 201.767.7576
www.crestron.com

Installation Guide - DOC. 8219A
(2049456)
12.17

Specifications subject to change without notice.