

## TSW-730 7" Room Scheduling Touch Screen

### DO Change the Button Inserts or Button Covers

The Crestron® TSW-730 Touch Screen ships with 10 “hard key” push buttons for quick access to commonly used functions. Optional, custom engravable button covers are available (TSW-730-BTNO and custom engraving sold separately). For a clean appearance, either column of buttons may be removed and covered using the included no-button covers.

To change the inserts or covers, use the following procedure:

1. Insert a small flat head screwdriver into the appropriate hole on the bottom of the TSW-730 to release its cover.

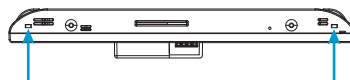

Insert a screwdriver to release the covers.

2. Gently remove the cover from the TSW-730.

3. If removing the button insert after removing the button cover, use a small flat head screwdriver to press the tabs, and then gently lift the button insert from the TSW-730. Refer to the following illustration for the tab locations on the button insert.

Touch Screen with Button Inserts

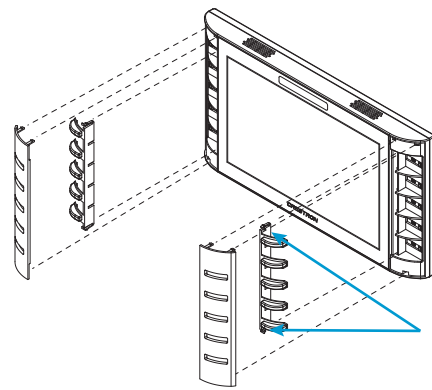

Use a screwdriver to release the button insert.

4. Carefully position the new cover over the front of the touch screen and press it into place.

Touch Screen with No-Button Covers

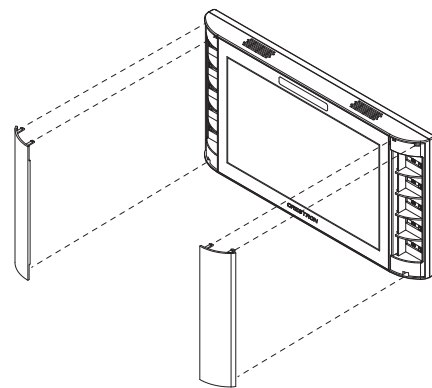

### DO Install the Touch Screen

The TSW-730 can be mounted into a standard electrical box or onto a flat surface. A tabletop enclosure and swivel mount (TSW-730-TTK and SMK-4SM/730, both sold separately) are also available.

#### Mounting into a U.S. Electrical Box

To mount the TSW-730 into a U.S. electrical box, use the following procedure:

1. Insert a small flat head screwdriver into the hole shown in the following illustration, and gently separate the back panel from the touch screen.

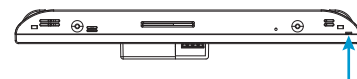

Insert a screwdriver to separate the back panel.

2. Use the four included 6-32 x 1-1/2" screws to attach the back panel to the electrical box.

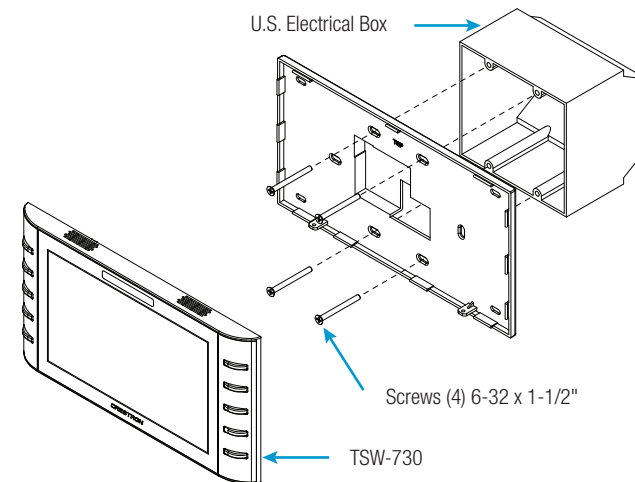

3. Make connections to the TSW-730 using Crestron power supplies for Crestron equipment.

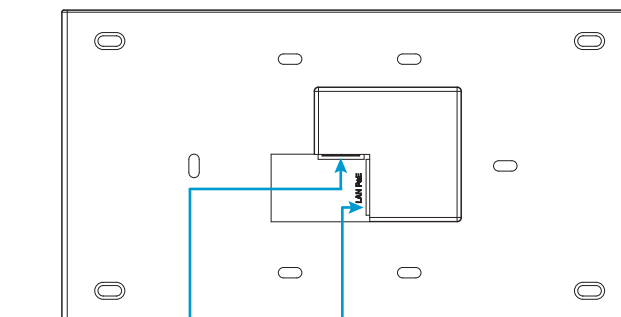

Occupancy Sensor Input:  
From Room Occupancy Sensor

LAN PoE:  
10BASE-T / 100BASE-TX  
Ethernet to LAN

### DO Check the Box

QUANTITY	PRODUCT	COLOR	PART NUMBER
1	Bit, Torx, T8		2025915
1	Cover, Plastic, No Buttons, Left Side, 4.5" x 1" x 0.625" <sup>1</sup>	Black	2033452
1	Cover, Plastic, No Buttons, Left Side, 4.5" x 1" x 0.625" <sup>2</sup>	White	2033451
1	Cover, Plastic, No Buttons, Right Side, 4.5" x 1" x 0.625" <sup>1</sup>	Black	2033450
1	Cover, Plastic, No Buttons, Right Side, 4.5" x 1" x 0.625" <sup>2</sup>	White	2033449
2	Screw, 4B x 3/4", Flat Head, Phillips		2019088
2	Screw, 4-40 x 1/4", Undercut Head, Phillips <sup>1</sup>	Black	2007152
2	Screw, 4-40 x 1/4", Undercut Head, Phillips <sup>2</sup>		2007160
2	Screw, 4-40 x 1/4", Flat Head, Torx <sup>1</sup>	Black	2025311
2	Screw, 4-40 x 1/4", Flat Head, Torx <sup>2</sup>		2025312
4	Screw, 6-32 x 1-1/2", Flat Head, Phillips		2031703

1. This part ships with the TSW-730-B-S.  
2. This part ships with the TSW-730-W-S.

PIN	DESCRIPTION
G	Ground
2	Occupancy sensor #2 status
1	Occupancy sensor #1 status
24	24 Vdc power

4. Carefully position the front of the touch screen over the back panel and gently snap it into place.

5. Use two of the included 4-40 x 1/4" screws to secure the TSW-730. For standard applications, use the Phillips screws. For secure applications, use the security type Torx screws along with the included Torx screwdriver bit.

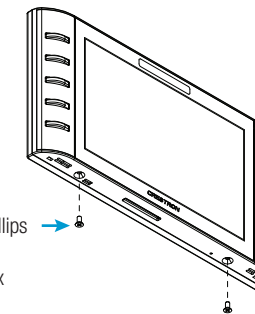

#### Mounting into a U.K. Electrical Box

To mount the TSW-730 into a U.K. electrical box, use the following procedure:

1. Insert a small flat head screwdriver into the hole shown in the following illustration, and gently separate the back panel from the touch screen.



Insert a screwdriver to separate the back panel.



2. Use the two included 4B x 3/4" screws to attach the back panel to the electrical box.

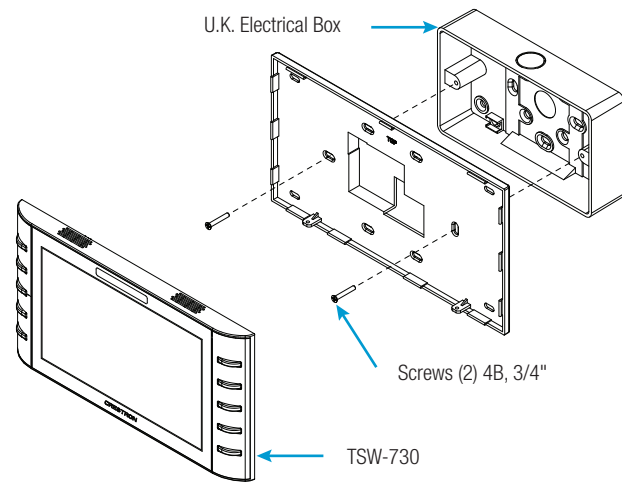

3. Make connections to the TSW-730 using Crestron power supplies for Crestron equipment.

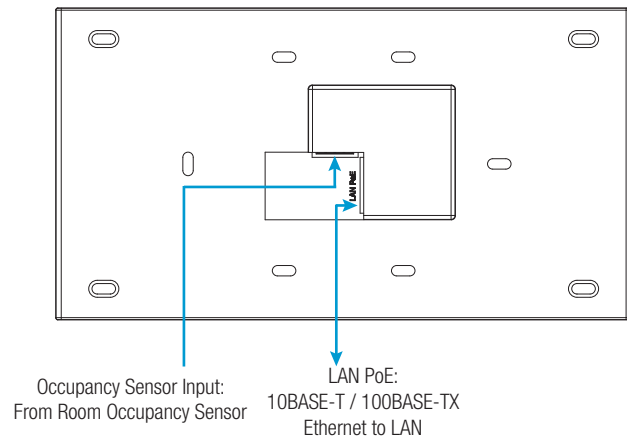

PIN	DESCRIPTION
G	Ground
2	Occupancy sensor #2 status
1	Occupancy sensor #1 status
24	24 Vdc power

4. Carefully position the front of the touch screen over the back panel and gently snap it into place.

5. Use two of the included 4-40 x 1/4" screws to secure the TSW-730. For standard applications, use the Phillips screws. For secure applications, use the security type Torx screws along with the included Torx screwdriver bit.

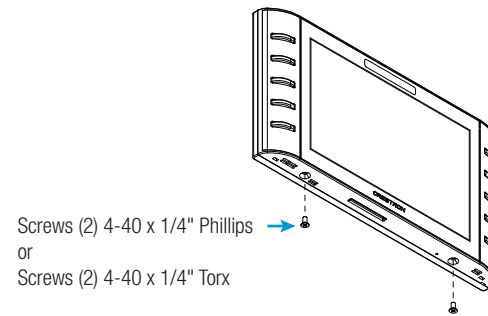

## DO Access the Setup Screens

**NOTE:** The TSW-730 can take up to 120 seconds to boot.

The setup screens enable basic configuration prior to regular operation of the TSW-730. To display the main setup screen, touch the screen while applying power to the unit.

**NOTE:** If no project has been loaded or if an invalid project has been loaded, the touch screen defaults to the main setup screen.

During regular operation of the touch screen, there are two ways to access the setup screens:

1. Place a button on the project main page, and assign the reserved join number (17242) that accesses the setup screens.
2. Press hard keys 1, 2, 3, and 4 on the left side of the touch screen display in sequence, twice (press 1, 2, 3, 4, 1, 2, 3, 4) within a 5-second period.

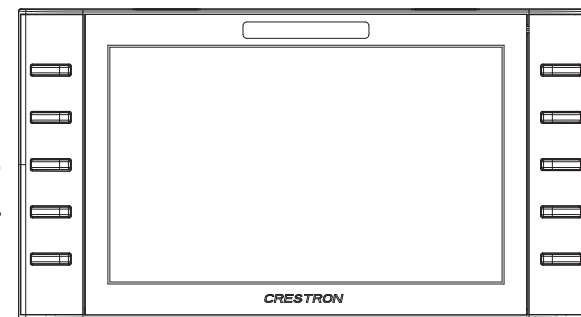

## DO Learn More

Visit the website for additional information and the latest firmware updates. To learn more about this product, use a QR reader application on your mobile device to scan the QR image.

**Crestron Electronics**  
15 Volvo Drive, Rockleigh, NJ 07647  
888.CRESTRON | www.crestron.com



**CE** As of the date of manufacture, the product has been tested and found to comply with specifications for CE marking.

### Federal Communications Commission (FCC) Compliance Statement

This device complies with part 15 of the FCC Rules. Operation is subject to the following two conditions:

(1) This device may not cause harmful interference, and (2) this device must accept any interference received, including interference that may cause undesired operation.

**Caution:** Changes or modifications not expressly approved by the manufacturer responsible for compliance could void the user's authority to operate the equipment.

**Note:** This equipment has been tested and found to comply with the limits for a Class B digital device, pursuant to part 15 of the FCC Rules. These limits are designed to provide reasonable protection against harmful interference in a residential installation. This equipment generates, uses and can radiate radio frequency energy and, if not installed and used in accordance with the instructions, may cause harmful interference to radio communications. However, there is no guarantee that interference will not occur in a particular installation.

If this equipment does cause harmful interference to radio or television reception, which can be determined by turning the equipment off and on, the user is encouraged to try to correct the interference by one or more of the following measures:

- Reorient or relocate the receiving antenna.
- Increase the separation between the equipment and receiver.
- Connect the equipment into an outlet on a circuit different from that to which the receiver is connected.
- Consult the dealer or an experienced radio/TV technician for help.

### Industry Canada (IC) Compliance Statement

CAN ICES-3(B)/NMB-3(B)

Crestron product development software is licensed to Crestron dealers and Crestron Service Providers (CSPs) under a limited non-exclusive, non-transferable Software Development Tools License Agreement. Crestron product operating system software is licensed to Crestron dealers, CSPs, and end-users under a separate End-User License Agreement. Both of these Agreements can be found on the Crestron website at [www.crestron.com/legal/software\\_license\\_agreement](http://www.crestron.com/legal/software_license_agreement).

The specific patents that cover Crestron products are listed at [www.patents.crestron.com](http://www.patents.crestron.com).

Certain Crestron products contain open source software. For specific information, please visit [www.crestron.com/opensource](http://www.crestron.com/opensource).

The product warranty can be found at [www.crestron.com/warranty](http://www.crestron.com/warranty).

The product warranty can be found at [www.crestron.com/warranty](http://www.crestron.com/warranty).

Crestron and the Crestron logo are either trademarks or registered trademarks of Crestron Electronics, Inc. in the United States and/or other countries. Other trademarks, registered trademarks, and trade names may be used in this document to refer to either the entities claiming the marks and names or their products. Crestron disclaims any proprietary interest in the marks and names of others. Crestron is not responsible for errors in typography or photography.

This document was written by the Technical Publications department at Crestron.

©2015 Crestron Electronics, Inc.