

# Wall Mount Bracket Kit: WMKB-1000L

## Description

The WMKB-1000L, a post-construction, optional wall mount kit, consists of brackets and mounting hardware (refer to table below for list of items included). It is designed specifically for Crestron's 4-inch wall-mounted touchpanels, the CT-1000 and LC-1000. The kit includes 10 individually packed, single-use bags of mounting material. Conveniently, each bag contains a template, two brackets, and four screws to mount one touchpanel.

### *Contents of WMKB-1000L*

ITEM	PART #	QUANTITY
Mounting Bracket	4001193	20 (or 2 per bag)
Pan Phillips Screw, #4-40 x 1"	2007186	40 (or 4 per bag)
Template	2005025	10 (or 1 per bag)

## Mounting Procedure

The Series 1000 touchpanel is a low-voltage unit that can be installed directly into a mounting surface. Each touchpanel utilizes the mounting hardware provided in a single bag from the WMKB-1000L. Complete the following mounting procedure in the order provided. The only tools required are masking tape (or equivalent), a gypsum board saw (or equivalent), and a #2 Phillips tip screwdriver.

1. Locate an area on the wall that is free of miscellaneous wiring and studs.
2. Make a small hole near the middle of the designated site; verify that the location is suitable.
3. Using masking tape (or equivalent), fasten template to mounting surface; verify that the template is level.
4. Cut out and remove the traced shape of the mounting surface (refer to illustration after this step).

### *Removing Template Cut Out*

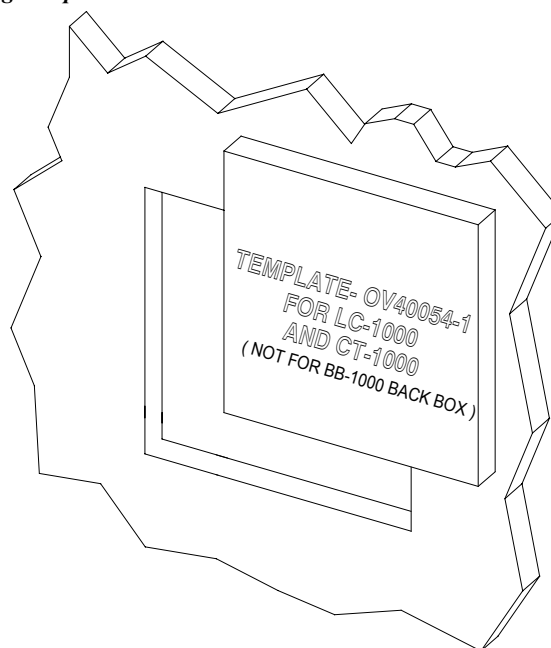

5. Use four pan head screws, supplied, to attach two mounting brackets to the touchpanel (refer to illustration after this step). Do not tighten screws. The screw threads should catch the mounting brackets, but not pass more than 1/16" through to the other side of the opening.

*Mounting Bracket/Touchpanel Assembly*

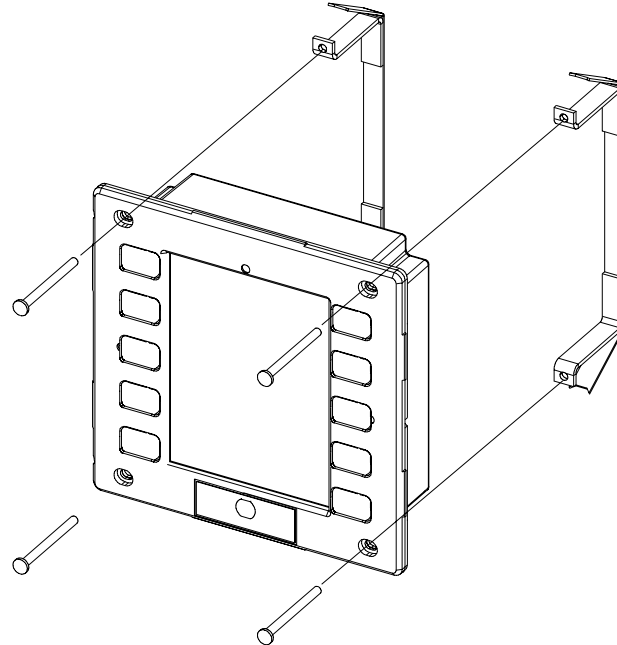

6. Attach the Cresnet cable in the wall to the connector on the back of the touchpanel. If necessary, refer to the latest revision of the Series 1000 Operations Guide (Doc. 5813) for connector and hookup details. The guide is available from the Crestron website ([www.crestron.com](http://www.crestron.com)).
7. Position the mounting bracket/touchpanel assembly (less the plastic buttons and cover) over the opening and apply equal pressure on the four screw heads of the touchpanel until the assembly slides into place.

---

**CAUTION:** Do not apply excessive pressure to the touchscreen display during installation. Doing so can crack the screen and damage the touchpanel.

---

8. Tighten four screws until mounting bracket/touchpanel assembly is secure within the opening.
9. Install the plastic buttons by firmly pressing them into place. If buttons are engraved, be sure to match button engraving with button functionality.
10. Firmly press on the plastic cover over the touchpanel (refer to illustration after this step).

---

**NOTE:** If necessary, refer to the latest revision of the Series 1000 Operations Guide (Doc. 5813) for a touchpanel removal procedure.

---

*Secure Mounting Bracket/Touchpanel Assembly and Add Plastic Buttons and Cover*

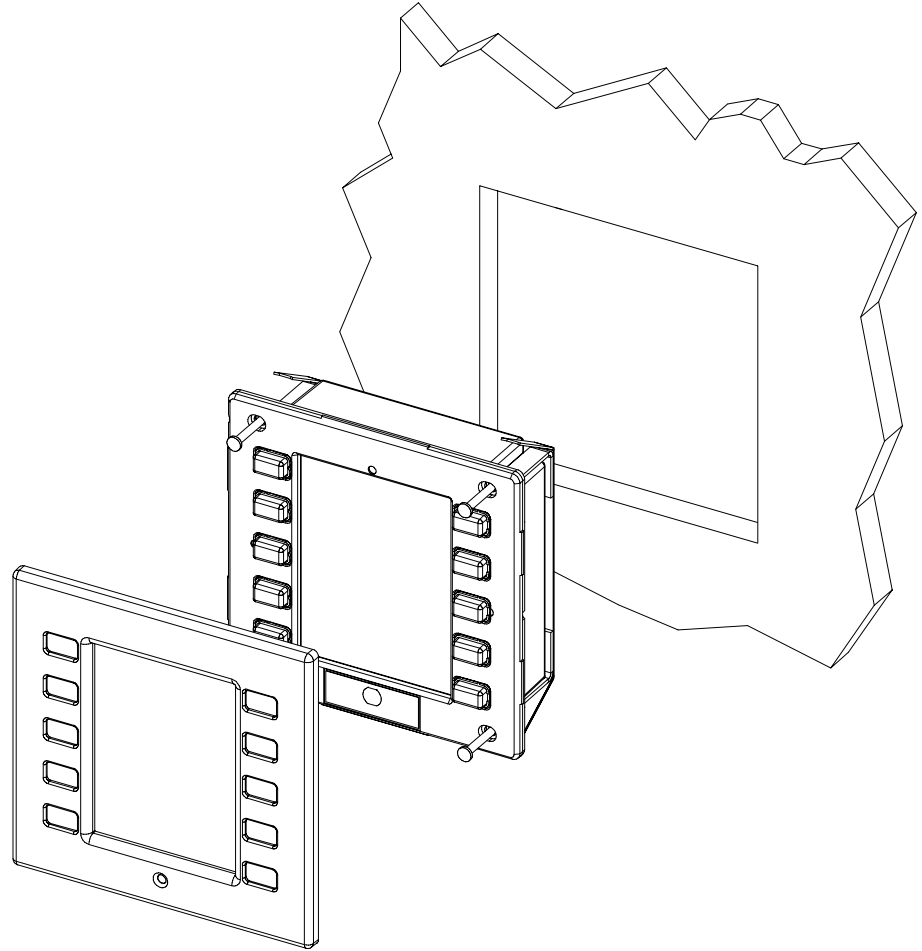

---

## Further Inquiries

If after reviewing this Installation Guide, you cannot locate specific information or have questions, please take advantage of Crestron's award winning customer service team by calling:

- In the US and Canada, call Crestron's corporate headquarters at 1-888-CRESTRON [1-888-273-7876].
- In Europe, call Crestron International at +32-15-50-99-50.
- In Asia, call Crestron Asia at +852-2341-2016.
- In Latin America, call Crestron Latin America at +5255-5093-2160.
- In Australia and New Zealand, call Crestron Pacific at +613-9480-2999.

---

# Return and Warranty Policies

## Merchandise Returns / Repair Service

1. No merchandise may be returned for credit, exchange, or service without prior authorization from CRESTRON. To obtain warranty service for CRESTRON products, contact the factory and request an RMA (Return Merchandise Authorization) number. Enclose a note specifying the nature of the problem, name and phone number of contact person, RMA number, and return address.
2. Products may be returned for credit, exchange, or service with a CRESTRON Return Merchandise Authorization (RMA) number. Authorized returns must be shipped freight prepaid to CRESTRON, 6 Volvo Drive, Rockleigh, N.J., or its authorized subsidiaries, with RMA number clearly marked on the outside of all cartons. Shipments arriving freight collect or without an RMA number shall be subject to refusal. CRESTRON reserves the right in its sole and absolute discretion to charge a 15% restocking fee, plus shipping costs, on any products returned with an RMA.
3. Return freight charges following repair of items under warranty shall be paid by CRESTRON, shipping by standard ground carrier. In the event repairs are found to be non-warranty, return freight costs shall be paid by the purchaser.

## CRESTRON Limited Warranty

CRESTRON ELECTRONICS, Inc. warrants its products to be free from manufacturing defects in materials and workmanship under normal use for a period of three (3) years from the date of purchase from CRESTRON, with the following exceptions: disk drives and any other moving or rotating mechanical parts, pan/tilt heads and power supplies are covered for a period of one (1) year; touchscreen display and overlay components are covered for 90 days; batteries and incandescent lamps are not covered.

This warranty extends to products purchased directly from CRESTRON or an authorized CRESTRON dealer. Purchasers should inquire of the dealer regarding the nature and extent of the dealer's warranty, if any.

CRESTRON shall not be liable to honor the terms of this warranty if the product has been used in any application other than that for which it was intended, or if it has been subjected to misuse, accidental damage, modification, or improper installation procedures. Furthermore, this warranty does not cover any product that has had the serial number altered, defaced, or removed.

This warranty shall be the sole and exclusive remedy to the original purchaser. In no event shall CRESTRON be liable for incidental or consequential damages of any kind (property or economic damages inclusive) arising from the sale or use of this equipment. CRESTRON is not liable for any claim made by a third party or made by the purchaser for a third party.

CRESTRON shall, at its option, repair or replace any product found defective, without charge for parts or labor. Repaired or replaced equipment and parts supplied under this warranty shall be covered only by the unexpired portion of the warranty.

Except as expressly set forth in this warranty, CRESTRON makes no other warranties, expressed or implied, nor authorizes any other party to offer any warranty, including any implied warranties of merchantability or fitness for a particular purpose. Any implied warranties that may be imposed by law are limited to the terms of this limited warranty. This warranty statement supercedes all previous warranties.

### Trademark Information

*All brand names, product names, and trademarks are the sole property of their respective owners. Windows is a registered trademark of Microsoft Corporation. Windows95/98/Me/XP and WindowsNT/2000 are trademarks of Microsoft Corporation.*



**Crestron Electronics, Inc.**  
15 Volvo Drive Rockleigh, NJ 07647  
Tel: 888.CRESTRON  
Fax: 201.767.7576  
www.crestron.com

**Installation Guide – DOC. 6283**  
**07.04**

Specifications subject to  
change without notice.