

Rack Mount Kit: RMK-TPS3000L

The RMK-TPS3000L is a complete rack mount kit that has been developed for the Crestron TPS-3000L series of wall-mounted touchpanels. Use the supplied hardware to attach the touchpanel to the rack mount kit.

Supplied Hardware

The RMK-TPS3000L consists of a mounting plate and screws to secure the touchpanel to the plate. These items along with the touchpanel produce an assembly that can be attached to a rack. Rack-mounting hardware is not supplied.

DESCRIPTION	PART NUMBER	QUANTITY
Rack Mounting Plate, 6 RU High	MTPL02885-1	1
Screw, 6-32, 1/4"L, Pan, Phil, Blk	SR06-32-0R2500-4	4

Assembly View

Assembly of the RMK-TPS3000L to the touchpanel is illustrated to the right. Before installation, remove the plastic touchpanel faceplate if it is attached. Use a #2 Phillips head screwdriver to secure the touchpanel to the rack mounting plate with the four supplied screws (do not use the screws supplied with the touchpanel). Torque should not exceed 11 in-lbs (1.243 N*m). Use caution when handling the touchpanel as not to damage or scratch the view screen. The RMK-TPS3000L is designed to occupy six rack spaces, 10.47 inches (26.59 cm) high. After the touchpanel is secured to the rack plate, reinstall the touchpanel faceplate and attach the plate to the rack.

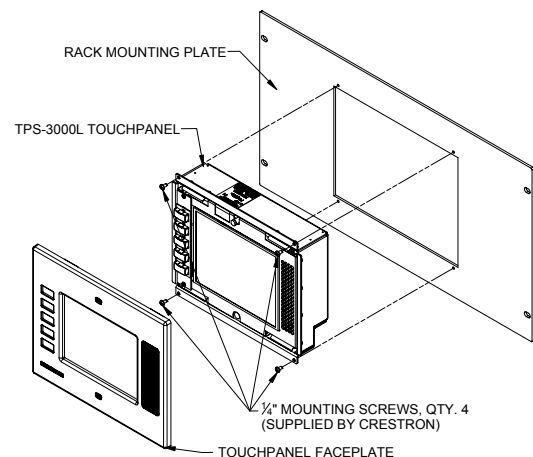

Further Inquiries

If after reviewing this Installation Guide, you cannot locate specific information or have questions, please take advantage of Crestron's award winning customer service team by calling:

- In the US and Canada, call Crestron's corporate headquarters at 1-888-CRESTRON [1-888-273-7876].
- In Europe, call Crestron International at +32-15-50-99-50.
- In Asia, call Crestron Asia at +852-2341-2016.
- In Latin America, call Crestron Latin America at +5255-5093-2160.
- In Australia and New Zealand, call Crestron Pacific at +613-9480-2999.

As of the date of manufacture, the RMK-TPS3000L has been tested and found to comply with specifications for CE marking.



Return and Warranty Policies

Merchandise Returns / Repair Service

1. No merchandise may be returned for credit, exchange, or service without prior authorization from CRESTRON. To obtain warranty service for CRESTRON products, contact the factory and request an RMA (Return Merchandise Authorization) number. Enclose a note specifying the nature of the problem, name and phone number of contact person, RMA number, and return address.
2. Products may be returned for credit, exchange, or service with a CRESTRON Return Merchandise Authorization (RMA) number. Authorized returns must be shipped freight prepaid to CRESTRON, Cresskill, N.J., or its authorized subsidiaries, with RMA number clearly marked on the outside of all cartons. Shipments arriving freight collect or without an RMA number shall be subject to refusal. CRESTRON reserves the right in its sole and absolute discretion to charge a 15% restocking fee, plus shipping costs, on any products returned with an RMA.
3. Return freight charges following repair of items under warranty shall be paid by CRESTRON, shipping by standard ground carrier. In the event repairs are found to be non-warranty, return freight costs shall be paid by the purchaser.

CRESTRON Limited Warranty

CRESTRON ELECTRONICS, Inc. warrants its products to be free from manufacturing defects in materials and workmanship under normal use for a period of three (3) years from the date of purchase from CRESTRON, with the following exceptions: disk drives and any other moving or rotating mechanical parts, pan/tilt heads and power supplies are covered for a period of one (1) year; touchscreen display and overlay components are covered for 90 days; batteries and incandescent lamps are not covered.

This warranty extends to products purchased directly from CRESTRON or an authorized CRESTRON dealer. Purchasers should inquire of the dealer regarding the nature and extent of the dealer's warranty, if any.

CRESTRON shall not be liable to honor the terms of this warranty if the product has been used in any application other than that for which it was intended, or if it has been subjected to misuse, accidental damage, modification, or improper installation procedures. Furthermore, this warranty does not cover any product that has had the serial number altered, defaced, or removed.

This warranty shall be the sole and exclusive remedy to the original purchaser. In no event shall CRESTRON be liable for incidental or consequential damages of any kind (property or economic damages inclusive) arising from the sale or use of this equipment. CRESTRON is not liable for any claim made by a third party or made by the purchaser for a third party.

CRESTRON shall, at its option, repair or replace any product found defective, without charge for parts or labor. Repaired or replaced equipment and parts supplied under this warranty shall be covered only by the unexpired portion of the warranty.

Except as expressly set forth in this warranty, CRESTRON makes no other warranties, expressed or implied, nor authorizes any other party to offer any other party to offer any warranty, including any implied warranties of merchantability or fitness for a particular purpose. Any implied warranties that may be imposed by law are limited to the terms of this limited warranty. This warranty statement supercedes all previous warranties.

Trademark Information

All brand names, product names, and trademarks are the sole property of their respective owners. Windows is a registered trademark of Microsoft Corporation. Windows95/98/Me/XP and WindowsNT/2000 are trademarks of Microsoft Corporation.