

## Shade Motor Bracket Installation and Motor Programming

The Crestron® CSA-ARCH3-BRKT Series shade brackets allow Crestron shades to be mounted on a wall, ceiling, pocket, or window jamb. The mounting brackets are adjustable to fine-tune the installation without removing the mounting brackets from the wall.



### Shade Mounting

The CSA-ARCH3-BRKT Series shade brackets are mounted to the wall or window jamb using the two supplied brackets. The end caps (optional) and roller shade assembly then attach to the brackets.

#### CAUTIONS:

- There is risk of personal injury and equipment damage if the shade or associated parts fall during mounting. Use care when mounting. Use proper mounting hardware for the mounting surface (for example, screws or bolts) when securing the brackets to the surface.
- Two or more people are required to properly mount the shades. Three or more people are required to properly mount large shades and medium-sized coupled shades.

#### NOTES:

- The screws provided with the mounting brackets are intended for use on walls (or jambs) with wood or metal blocking. These screws should not be used for hollow drywall or masonry installations. It is the responsibility of the installer to make sure that the mounting method used is secure.
- Ensure that all mounting brackets are level and on the same plane.
- All shades must be aligned along a single axis (no off-angle positioning).

### Mount the Brackets

1. Check for a proper fit by holding the roller shade assembly in the approximate mounting location. If using a fascia, use the fascia to measure the proper distance between mounting brackets. The brackets should be mounted flush with the end of the fascia.
2. Mark the locations of the brackets and make sure that the mounting points are level and on the same plane. Use a laser level or snap a chalk line to mark the locations of the brackets. The brackets should be spaced according to the specifications on the order form.

**NOTE:** End caps are used only when the shade is outside mounted and fascia is used. If inside mounted, end caps are not required unless the shade brackets protrude from the window opening. Adding end caps for an inside mount increases the light gap.

3. If using end caps, attach them to the mounting brackets according to their stamped directions. The end caps snap into place.

## Shade Motor Bracket Installation and Motor Programming

4. Mount the brackets to the outside of the window frame (outside mount) or the inside of the window frame (inside mount). Use hardware that is appropriate for the mounting surface. Make sure the brackets are level and mounted to a flat surface.
- The idler bracket mounts on the right-side of the window opening.
  - The motor bracket mounts on the left-side of the window opening.

### NOTES:

- The stamped **L** and **R** should face the wall and window.
- For inside mounts, secure the mounting brackets into the window jamb or the window header.
- When using a fascia, align the brackets with the width of the fascia before attaching them to the header.

### Outside Mount (CSA-ARCH3-BRKT)

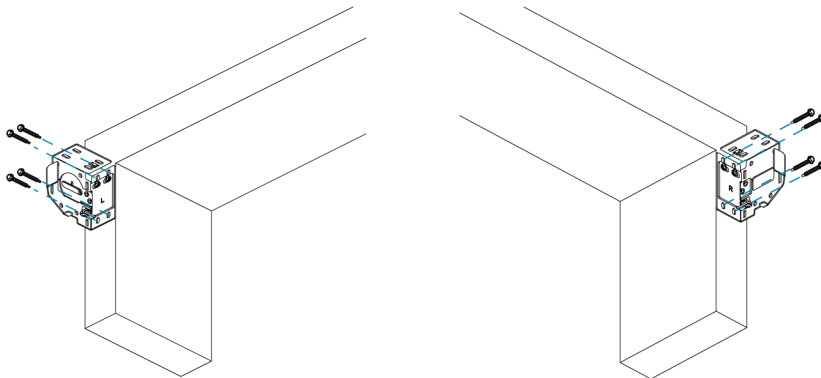

### Inside Mount (CSA-ARCH3-BRKT)



### Outside Mount (CSA-ARCH3-BRKT-DUAL)

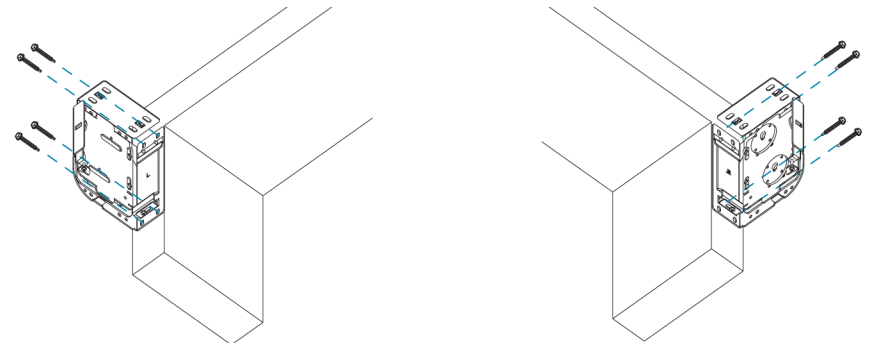

## Shade Motor Bracket Installation and Motor Programming

Inside Mount (CSA-ARCH3-BRKT-DUAL)

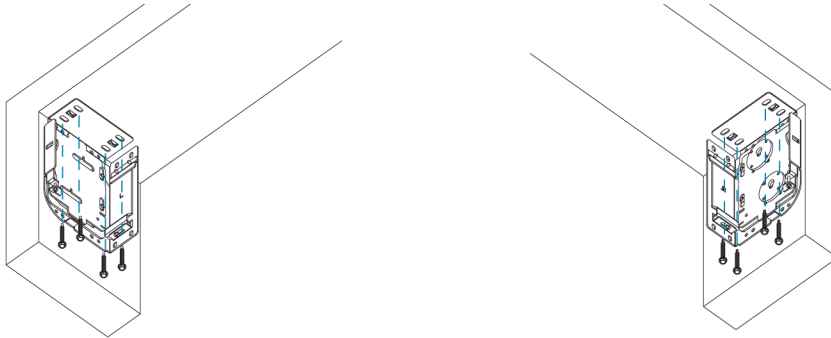

## Mount the Roller Shade Assembly

### CAUTIONS:

- There is risk of personal injury and equipment damage if the shade or associated parts fall during installation. Use care when mounting. Use proper mounting hardware (e.g., screws or bolts) for the mounting surface when securing the brackets to the surface.
- Proper installation of shades requires two or more people. Large shades and medium-sized coupled shades will require three people.

Once the mounting brackets are installed, mount the roller shade assembly:

1. Insert the idler pin into the top of the keyhole on the right bracket, and slide it down into the keyhole. The idler pin sits on the vertical adjustment screw.

**Insert the Idler Pin into the Keyhole (CSA-ARCH3-BRKT)**

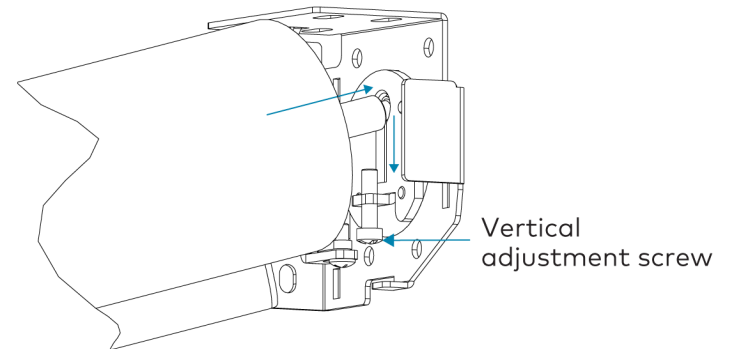

## Shade Motor Bracket Installation and Motor Programming

### Insert the Idler Pins into the Keyholes (CSA-ARCH3-BRKT-DUAL)

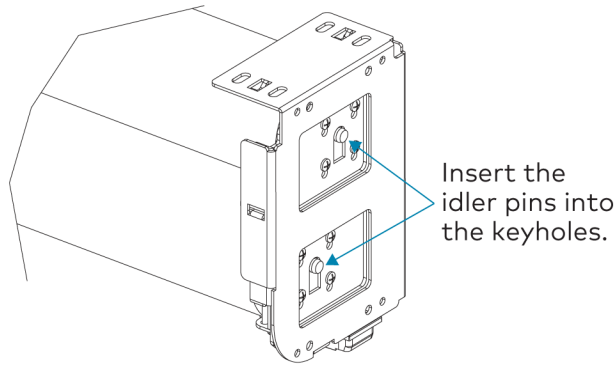

2. Raise the motor end of the roller shade assembly to the motor bracket.
3. Push the roller shade assembly toward the idler bracket to compress the spring on the idler pin and align the tab on the motor assembly with the hole in the motor bracket.

### Align the Motor with the Motor Bracket (CSA-ARCH3-BRKT)

When the bracket is installed inside a pocket, the motor must be rotated 90 degrees to clear the tab. Rotate the motor so it aligns with the mounting bracket.

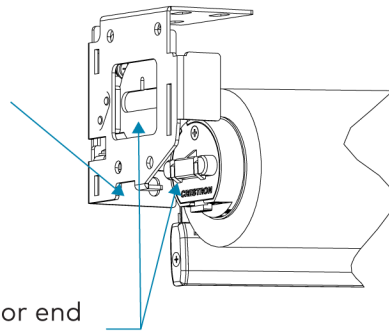

Maneuver the motor end into the bracket slot.

4. Push the tab on the motor assembly into the hole in the motor bracket. When the shade is properly seated, the two clips spring down to secure the motor to the bracket. Make sure that the shade is properly mounted before letting go.

### Secure the Motor to the Motor Bracket (CSA-ARCH3-BRKT)

Plastic clips lock the motor into its bracket when the motor is fully inserted. Pull the motor gently to the right to ensure that the motor is securely locked into place.

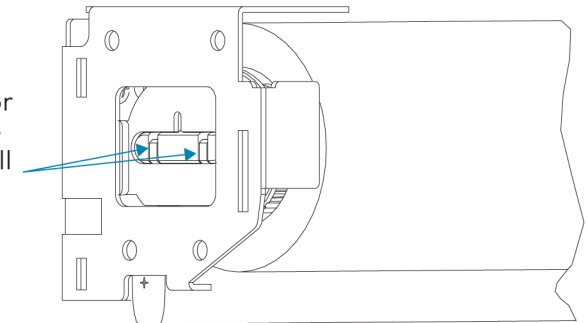

### Secure the Motor to the Motor Bracket (CSA-ARCH3-BRKT-DUAL)

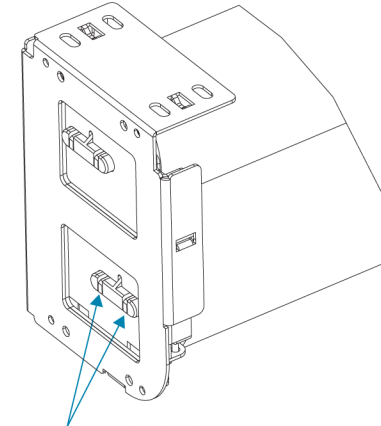

Plastic clips lock the motor into its bracket when the motor is fully inserted. Pull the motor gently to the right to ensure that the motor is securely locked into place.

## Shade Motor Bracket Installation and Motor Programming

### Adjust the Roller Shade Assembly

Once the roller shade assembly is mounted, make adjustments to level the shade and center it in the opening.

#### WARNINGS:

- Care has been taken to make sure that the shade is properly balanced. Prior to initial operation, please confirm that the brackets have been adjusted so that the shade hangs level and plumb. Upon startup, run the shade all the way down and check for plumb. Observe the shade closely as it rolls up. If the shade begins to telescope, stop immediately and take the appropriate action to make sure that the shade tracks properly. To prevent damage to the fabric from telescoping, do not leave the shade unattended during the first few cycles of operation. Failure to follow these instructions may result in damage to the edge of the fabric, which is not covered by the warranty.
- If the roll-up diameter is close to the maximum allowance, do not use the vertical adjustment screw to level the shade. The fabric may come in contact with the bracket, fascia, or other hardware, which may cause damage to the fabric. Remount the bracket to level the shade.

Situations that may cause telescoping:

- The shade is not perfectly level.
- The shade may bump into objects while traveling up or down.
- The HVAC ductwork is blowing on the shade, or air is coming in through a window.
- A foreign object is stuck to the shade fabric (for example tape, bugs, dust, etc.).

Ways to prevent telescoping:

- Use the leveling features built into the shade brackets to make sure the shade is level. If the bracket adjustment is not enough to compensate, use a shim to level the system.

- Make sure that no obstructions exist near the window area that the shade could bump into while traveling (for example, latches and cranks).
- Direct HVAC airflow away from the shade, and make sure that windows are closed while operating the shade.
- Lower the shade all the way down to the bare tube (the shade will need to be placed into **Limit Setup** mode to allow the shade to travel below its lower limit). Inspect the front and back of the shade to make sure that no foreign objects are stuck to the shade fabric.

#### Adjust the Roller Shade Assembly (CSA-ARCH3-BRKT)

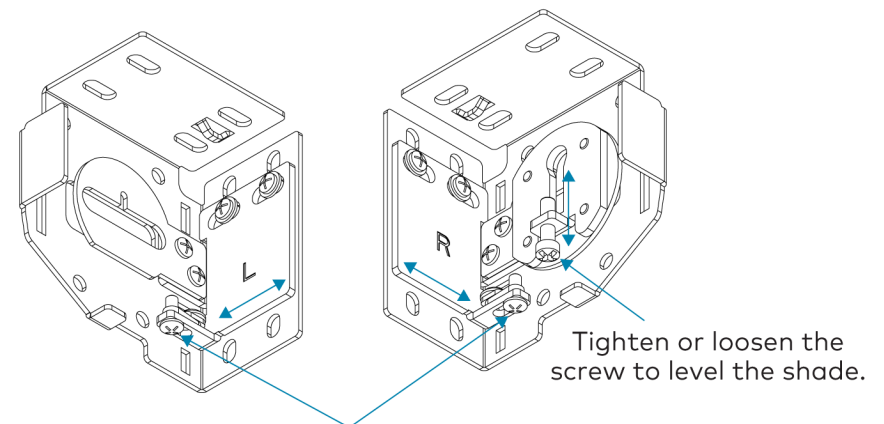

Loosen the screws, adjust the shade so that it is centered in the opening, and then tighten the screws to lock the shade into place.

## Shade Motor Bracket Installation and Motor Programming

### Adjust the Roller Shade Assembly (CSA-ARCH3-BRKT-DUAL)

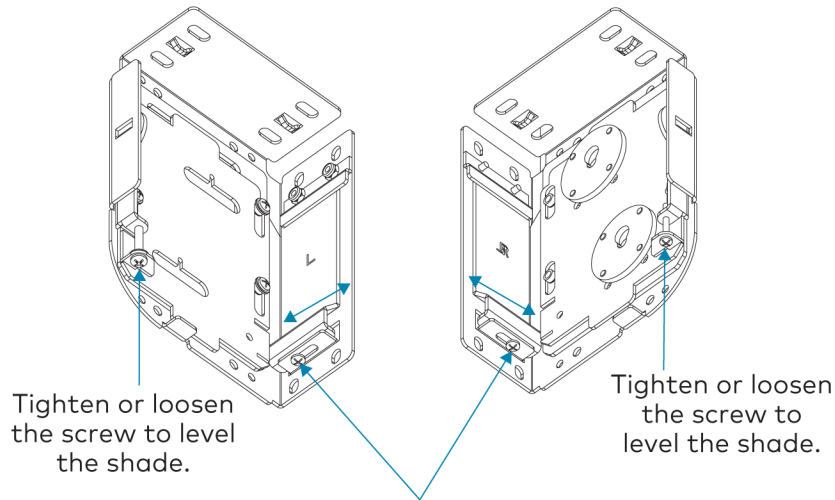

Loosen the screws, adjust the shade so that it is centered in the opening, and then tighten the screws to lock the shade into place.

If the shade is still telescoping, it can be re-shimmed by applying a small (1 in. x 1 in.) piece of tape to the end of the tube that the fabric should move toward. Make sure that the tape is placed on the bare tube for best results. The shade must be rolled all the way down past its lower limit. To do this, place the shade motor into **Limit Setup** mode.

- If the fabric is telescoping to the left, place the tape on the right side of the tube.
- If the fabric is telescoping to the right, place the tape on the left side of the tube.

### Swap the Idler and Motor Ends

The roller shade assembly can be mounted so that the idler and motor ends are located in the ends of the tube opposite where they were when received from the factory (i.e., the idler end is on the left and the motor end is on the right). Swapping the idler and motor ends allows the roller shade to still roll off of the proper side of the tube. This might be necessary if the control or power wires were run to the wrong side of the window. If this is necessary, the idler mount in the right bracket and motor mount in the left bracket will need to be swapped. The left and right mounting brackets remain on their intended side.

Swapping the hardware requires a Phillips screwdriver.

### Swap the Bracket Hardware (CSA-ARCH3-BRKT)

1. Note the orientation of the motor mount in the left-hand bracket, and then remove the mount along with the two screws. Keep all hardware for reassembly.

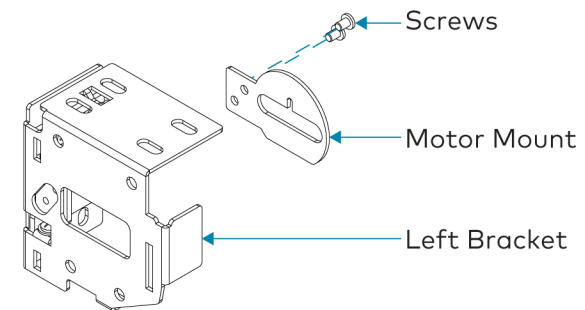

2. Note the orientation of the idler mount in the right-hand bracket, and then remove the mount along with the two screws. Keep all hardware for reassembly.

## Shade Motor Bracket Installation and Motor Programming

- Remove the four screws from the back of the idler mount, and separate the assembly.

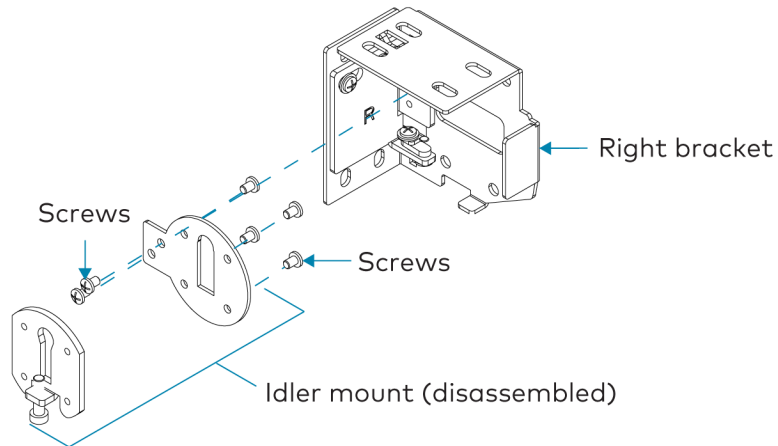

- Without rotating or flipping the motor mount, transfer it from the left-hand bracket to the right-hand bracket. Reassemble using the screws removed earlier.

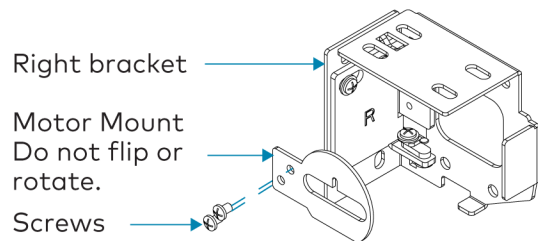

- Without rotating or flipping the idler mount, transfer it from the right-hand bracket to the left-hand bracket. Reassemble using the screws removed earlier. Make sure that the screw head on the vertical adjustment screw faces down.

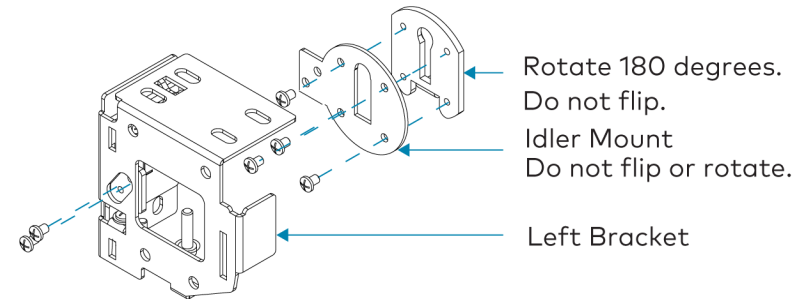

## Swap the Bracket Hardware (CSA-ARCH3-BRKT-DUAL)

- Fully loosen the vertical adjustment screws on the L and R brackets until the screw separates from the backing plate. The screws will stay secured to the mounting plate.

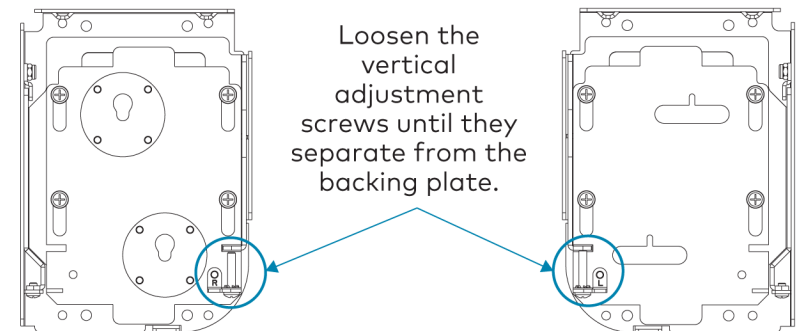

## Shade Motor Bracket Installation and Motor Programming

- Remove the four screws and washers that are circled below from the L and R brackets. Keep them for reassembly.



- Remove the keyhole mounting plate from the L bracket and the motor mounting plate from the R bracket.
- Remove the eight screws from the back of the keyhole mounting plate that secure the two keyholes to the plate. Keep all parts for reassembly.

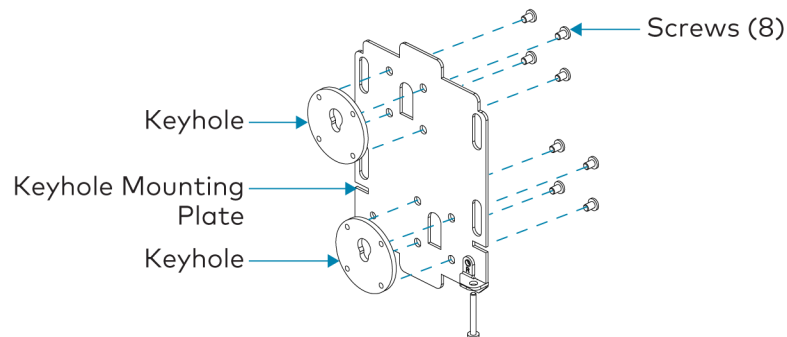

- Remove the vertical adjustment screw holder from the L and R brackets by removing the screw on the back of the mounting plate. Keep for reassembly.

**NOTE:** The vertical adjustment screw holders are stamped L and R and will stay with the L and R brackets.

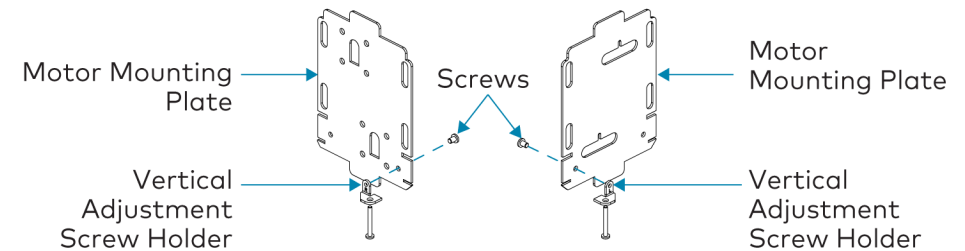

- Hold the keyhole mounting plate facing you. The top keyhole should be on the right.
- Secure the vertical adjustment screw holder (stamped L) to the left side of the keyhole mounting plate by inserting the screw through the rear of the keyhole mounting plate. Make sure the tab on the vertical adjustment screw holder fits in the slot in the keyhole mounting plate.

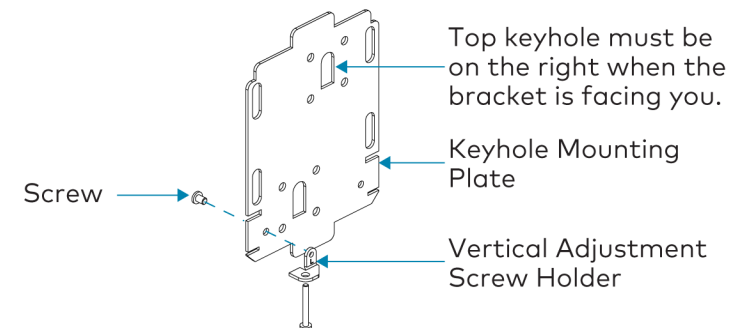



## Shade Motor Bracket Installation and Motor Programming

- Place the keyholes on the front of the plate and secure them with screws through the back of the plate. The large end of the keyhole must be on top.

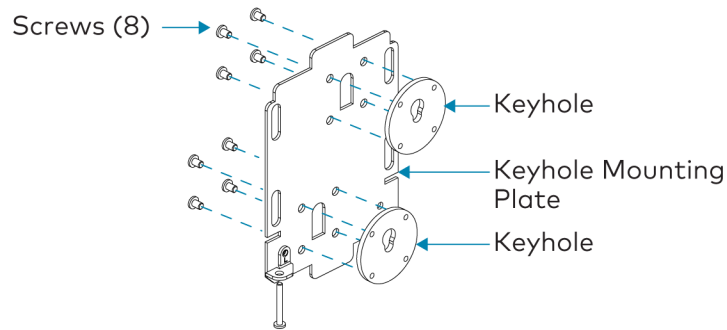

- Hold the motor mounting plate facing you. The top motor mount should be on the left.
- Secure the vertical adjustment screw holder (stamped R) to the right side of the motor mounting plate by inserting the screw through the rear of the motor mounting plate. Make sure the tab on the vertical adjustment screw holder fits in the slot in the motor mounting plate.

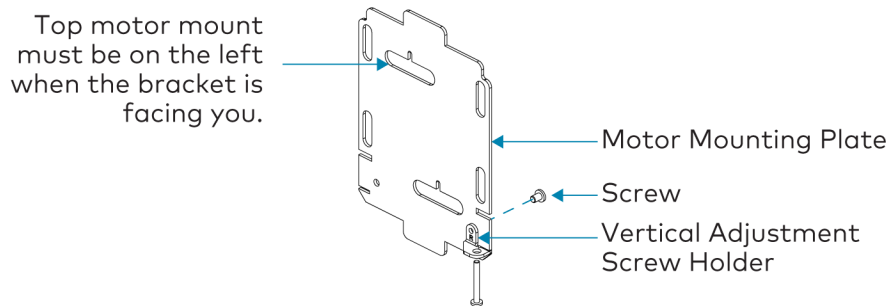

- Place the motor mounting plate into the R mounting bracket and install the four screws with washers that were previously removed. Screws need to be only hand tight.

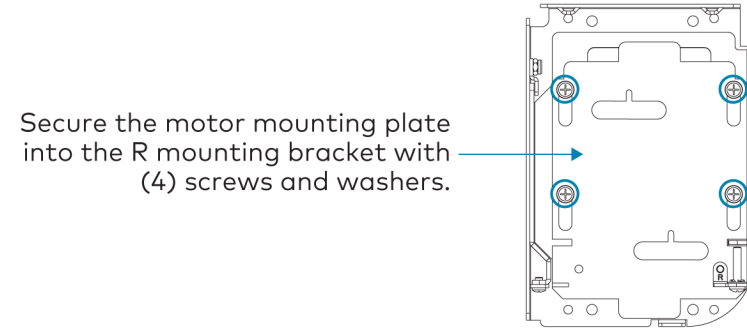

- Tighten the vertical adjustment screw so that it engages the bracket.
- Place the keyhole mounting plate into the L mounting bracket, and install the four screws with washers that were previously removed. Screws need to be only hand tight.

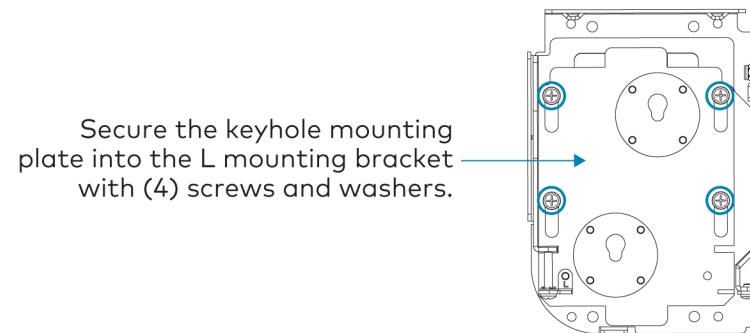

- Tighten the vertical adjustment screw so that it engages the bracket.

## Shade Motor Bracket Installation and Motor Programming

### Swap the Roller Shade Idler and Motor

If the idler and motor brackets have been swapped, remove the motor and idler from the tube and remount in the opposite ends, allowing the fabric to roll off of the tube in its intended manner

Swap the idler and motor ends of the roller shade.

1. Remove the motor by pulling on the motor head.
2. Use the idler removal tool to loosen the idler by rotating the idler counterclockwise. Pull the idler out of the tube.
3. Insert the motor into the tube end opposite from where it was removed.
4. Insert the idler into the tube end opposite from where it was removed.
5. Use the idler removal tool to tighten the idler; rotate the idler clockwise two turns, and then tighten until snug. Pull on the idler to confirm it is properly secured.

### Mount the Fascia

Once the assembly is installed and programmed, the fascia can be mounted.

Align the fascia with the mounting brackets and then press the fascia into place. The fascia assembles into place by snapping onto the tabs on the bracket. Place the top of the fascia on the top of the bracket first, and then press the bottom of the fascia into place on the bottom of the bracket.

To remove the fascia, pull the bottom of the fascia down to clear the bottom tab on the bracket. Then, pull the fascia away from the window and upward to release the top of the fascia.

#### Mount the Fascia (CSA-ARCH3-BRKT)

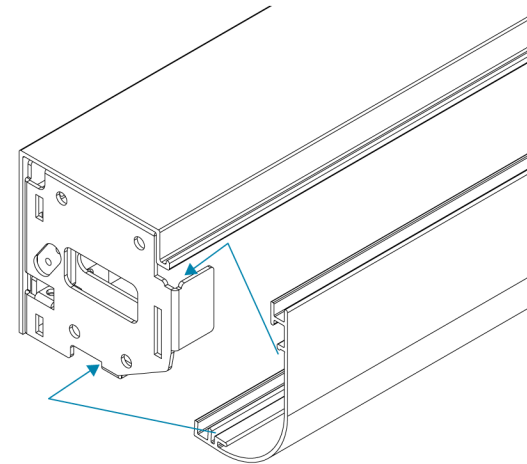

## Shade Motor Bracket Installation and Motor Programming

Top and Back Cover  
(Optional)

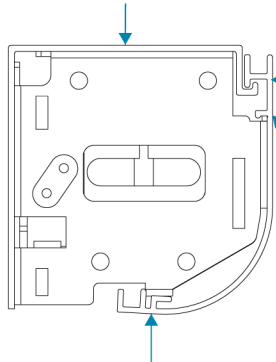

If the top and back cover is used, the fascia rests in the lip of the top and back cover.

The fascia snaps to the top of the bracket.

The fascia snaps to the bottom of the bracket.

**Mount the Fascia (CSA-ARCH3-BRKT-DUAL)**

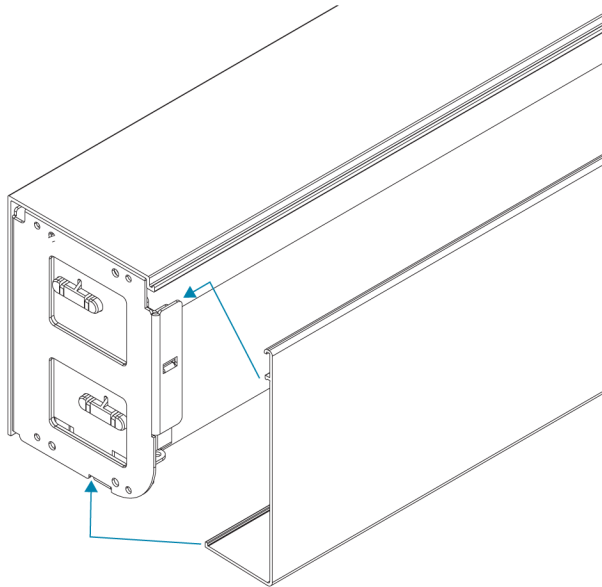

Top and Back Cover  
(Optional)

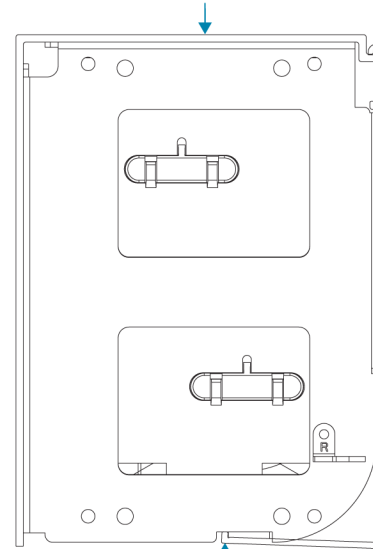

If the top and back cover is used, the fascia rests in the lip of the top and back cover.

The fascia snaps to the top of the bracket.

The fascia snaps to the bottom of the bracket.

## Shade Motor Bracket Installation and Motor Programming

### Motor Wiring

#### Routing the Cables

To ensure proper functionality and a clean look, consider the following when routing cables and making connections:

- The cables should exit the wall near the motor end of the shade assembly.
- Route the cables so that they remain out of sight.
- The brackets provide a cutout in the upper corner, which allows wiring to be easily run to the motor.
- A 2-pin connector may be required for shades with a large roll-up diameter.
- Use cable ties to secure the cables to the loop on the bracket.
- Ensure that the cables and connectors do not make contact with the shade fabric.

#### Making the Connections

##### NOTES:

- When making the connections, do not use CRESNET-HP cable with the small connector. When using CRESNET-HP cable, replace the connector on the motor pigtail with the larger connector that is supplied with the shade.
- All shades should be home run from the power supply (sold separately).

#### Cresnet QMT® Shade Motor with the Power and Control Coming from the Same Source

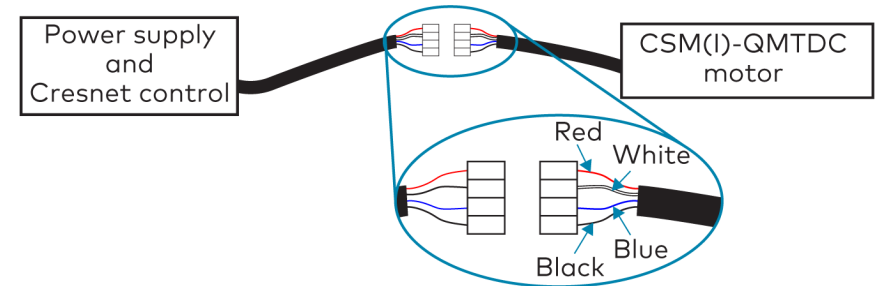

#### Cresnet QMT Shade Motor with the Power and Control Coming from Separate Sources

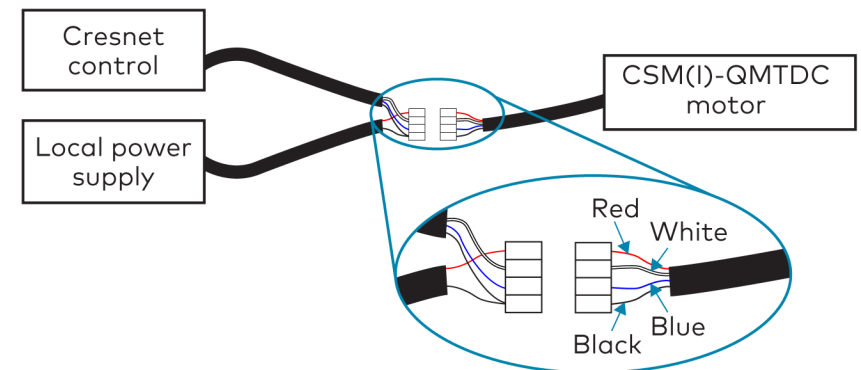

#### Wire the inNET EX® Wireless QMT Shade Motor

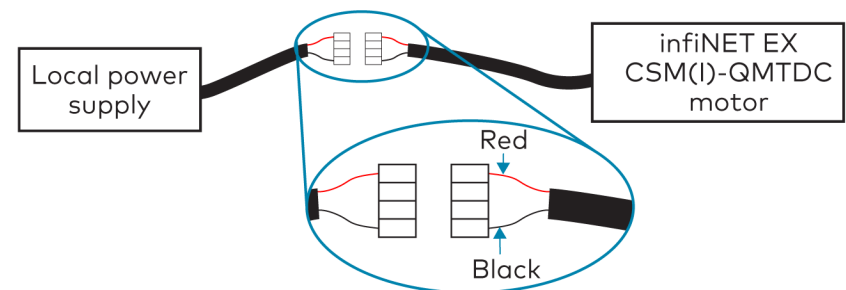

## Shade Motor Bracket Installation and Motor Programming



### Motor Programming

The Crestron® digital CSM(I)-QMTDC shade motors are programmed locally using the buttons on the motor. The information in this guide serves as a detailed programming overview of the Crestron CSM (I)-QMTDC shade motors.

**NOTE:** The procedures described in this document can also be performed remotely using a control system. The timeout and LED indicators are the same as described in this document.

### Controls and Indicators

The Crestron CSM(I)-QMTDC shade motors have **UP**, **SET**, and **DN** (down) push buttons that are used to program the shade. The shade motors have a multicolor LED that lights red, amber, green, blue, or white to provide confirmation, operating mode, and error state feedback. The **UP** button is located closest to the LED, the **SET** button is the second button from the LED, and the **DN** button is the third button from the LED.

Crestron CSM-QMTDC Motor Multicolor LED and Push Button Orientation

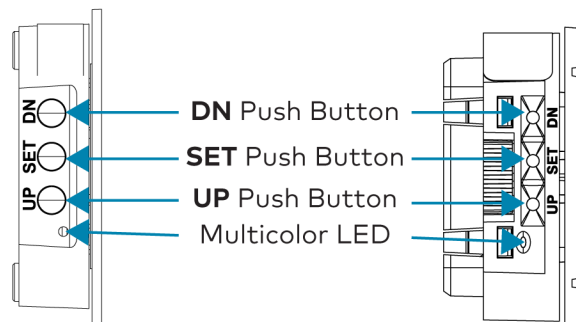

### Test the Shade

Before the shade is operated, test the motor to ensure that the shade travels in the correct direction when being operated.

**NOTE:** Before using the CSM(I)-QMTDC shade motor, ensure the device is using the latest firmware. Check for the latest firmware for the CSM (I)-QMTDC shade motor at [www.crestron.com/firmware](http://www.crestron.com/firmware). Firmware is loaded onto the device using Crestron Toolbox™ software.

### Test the Motor Direction

Press the **DN** button to lower the shade about 1 inch. If the shade travels up, reverse the motor direction.

**NOTE:** Reversing the motor direction resets all previously set limits. After either the upper or lower limit is set, the motor automatically enters **Limit Setup** mode for the opposite limit. Follow the procedure in [Set the Shade Limits](#) to reassign limits.

To reverse the shade direction, press and hold the **SET** button for 10 seconds. The red LED lights for 3 seconds.

## Shade Motor Bracket Installation and Motor Programming

### Test the Shade Travel

Test the travel of the shade fabric to ensure that it does not come in contact with building materials and that the upper and lower shade limits are properly set.

**WARNING:** Care has been taken to ensure that the shade is properly balanced. Prior to initial operation, confirm that the brackets are adjusted so that the shade hangs level and plumb. Upon startup, run the shade all the way down and check for plumb. Observe the shade closely as it rolls up. If the shade begins to telescope, stop immediately and take the appropriate action to ensure the shade tracks properly. To prevent damage to the fabric from telescoping, do not leave the shade unattended during the first few cycles of operation. Failure to follow these instructions may result in damage to the edge of the fabric, which is not covered by the warranty.

**NOTE:** For Crestron Horizontal Sheers, the lower limit is defined as the point before the hem bar tilts.

To test the lower limit:

1. Using the **DN** button, lower the shade until it reaches its lower limit. Stop and adjust the mounting brackets if the fabric contacts any building materials.
2. Verify that the shade stops at the desired lower limit. If the shade does not travel to the desired lower limit, adjust the shade limits. For details, refer to [Set the Shade Limits](#).

To test the upper limit:

1. Using the **UP** button, raise the shade until it reaches its upper limit. Stop and adjust the mounting brackets if the fabric contacts any building materials.
2. Verify that the shade stops at the desired upper limit. If the shade does not travel to the desired upper limit, adjust the shade limits. For details, refer to [Set the Shade Limits](#).

### Set the Shade Limits

If necessary, set the lower and upper shade limits. If the shade limits are not set, the red LED flashes three times, pauses for 1 second, flashes once, pauses for 5 seconds, and then repeats this code until the limits are set.

#### NOTES:

- **Limit Setup** mode exits after 8 seconds of inactivity.
- If a limit is not set after the upper or lower limit is saved, the motor automatically enters **Limit Setup** mode for the opposite limit. This typically occurs after the motor direction has been reversed and both limits are erased.
- For Crestron Horizontal Sheers, the lower limit is defined as the point before the hem bar tilts.

Set the lower limit for the shade:

1. Press and hold the **SET** button for 4 seconds to enter **Limit Setup** mode. The LED alternates between amber and green.
2. Press and release the **DN** button to begin lower limit setup. The green LED flashes.
3. Use the **UP** and **DN** buttons to set the shade to its desired position.
4. Press and hold **SET** for 4 seconds. The LED turns solid red to confirm that the lower limit was successfully set.

Set the upper limit for the shade:

1. Press and hold **SET** for 4 seconds to enter **Limit Setup** mode. The LED alternates between amber and green.
2. Press and release the **UP** button to begin upper limit setup. The amber LED flashes.
3. Use the **UP** and **DN** buttons to set the shade to its desired position.
4. Press and hold **SET** for 4 seconds. The LED turns solid red to confirm that the upper limit was successfully set.

## Shade Motor Bracket Installation and Motor Programming

### Joining an infiNET EX® Network (infiNET EX Interfaces Only)

The device connects to the Crestron network via the infiNET EX communications protocol. Use the procedures outlined below to join or leave an infiNET EX network and to verify communications between the device and the control system.

#### Joining an infiNET EX Network

Before a device can be used in a lighting system, it must first join an infiNET EX network by being acquired.

**NOTE:** A device can be acquired by only one gateway.

- Put the infiNET EX gateway into **Acquire** mode from the unit itself or from Crestron Toolbox, as described in its manual at [www.crestron.com/manuals](http://www.crestron.com/manuals).

**NOTE:** In an environment where multiple gateways are installed, only one gateway should be in **Acquire** mode at any time.

- Place the device into **Acquire** mode.
  - Press the **SET** button three times, and then press and hold it down (tap-tap-tap-press+hold) until the white LED on the device flashes once (this can take up to 10 seconds).
  - Release the button to start the acquire process. The LED flashes slowly to show that the device is actively scanning the infiNET EX network.
    - The LED turns on for 5 seconds to show that the device has been successfully acquired to the infiNET EX network.
    - The LED flashes quickly to indicate that the device was not successfully acquired by the infiNET EX network. Press the **SET** button to acknowledge failure to acquire the infiNET EX network. Ensure the gateway is in **Acquire** mode and within range before attempting the acquire process again.

- Once all devices have been acquired, take the gateway out of **Acquire** mode. Refer to the gateway's manual for details.

#### Leaving an infiNET EX Network

To leave an infiNET EX network, put the device into **Acquire** mode, as described in [Joining an infiNET EX Network](#) when no gateway is in **Acquire** mode.

#### Verifying Communications Status

To check the communications status of the device, tap the **SET** button three times and then press and hold it down (tap-tap-tap-press+hold) for up to 2 seconds. The LED flashes to indicate the communications status. Refer to the following table for details.

LED	Communications Status
Turns on for 5 seconds	The device is communicating with the control system.
Flashes twice	The device was previously joined to the network but is not communicating with the gateway.
Flashes once	The device is not joined to the network.

## Shade Motor Bracket Installation and Motor Programming

### LED Diagnostics

The LED flashes to provide a visual reference that the motor is operating normally or if it is in an error state.

### Normal Operation

The following table provides a list of possible LED patterns encountered during normal operation. All LEDs extinguish after 1 minute of inactivity if there are no errors to report.

#### LED Patterns

LED Pattern	LED Color	Operating Mode
Two fast flashes, then pause (1/8-second on, 1/8-second off, 1/8-second on, 5/8-second off)	Blue	A firmware upgrade over the Cresnet® network is in progress.
Slow flash (1/2-second on, 1/2-second off)	Blue	The motor's internal firmware upgrade is in progress.
Solid	Blue	The motor is in <b>Bootloader</b> mode.
Fast flash (1/4-second on, 1/4-second off)	White	The motor is in <b>Identify</b> mode.
Slow flash (1/2-second on, 1/2-second off)	Green	The motor is moving from a local button press.
Solid	Green	The motor is communicating with the control system program.
Slow flash (1/2-second on, 1/2-second off)	Red	The motor is not communicating with the control system.

### Error State

Crestron CSM(I)-QMTDC motors display error codes using the red LED on the interface. The LED flashes a pattern to indicate the error.

For example, when a 3-3 LED flash pattern occurs, the LED flashes three times, pauses for 1 second, flashes three times, pauses for 5 seconds, and then repeats until the error is corrected. When a 2-1 LED flash pattern occurs, the LED flashes two times, pauses for 1 second, flashes once, pauses for 5 seconds, and then repeats this code until the error is corrected.

The flash patterns are listed in the following table. Refer to [Troubleshooting](#) for possible corrections.

#### LED Blinking Patterns

LED Error Code	Error State
3-1	The motor limits are not set.
3-3	An obstruction is blocking the shade fabric from moving freely.
3-4	A motor over-current error exists. Check for obstacles or any sources of excessive friction.
3-5	A motor duty-cycle error exists. Reduce the operating duty cycle of the motor to correct the error.
3-6	There is a communications error between the motor and Cresnet or infiNET EX control board.
2-1	There is no traffic on the network. Check to ensure that proper Cresnet wiring is maintained, or for infiNET EX devices, ensure that the motor is connected to a gateway.
2-2	The motor is not being polled by the control system. Ensure that the Net ID matches the control system program and that the program is running on the control system.



## Shade Motor Bracket Installation and Motor Programming

### Troubleshooting

The following table provides corrective action for possible trouble situations. If further assistance is required, please contact a Crestron customer service representative.

#### Crestron CSM(I)-QMTDC Motor Troubleshooting

Trouble	Possible Cause(s)	Action
The motor cannot be controlled, and all of the LEDs are off.	There is no power provided to the motor.	Check the power connections between the power supply and motor.
	The power connection is reversed between the motor and the power supply.	Ensure that the power connection to the motor is not reversed.
The motor moves in the opposite direction.	The motor direction is reversed.	Reverse the direction of the motor.
The motor intermittently stops working.	The motor is exceeding its maximum duty cycle.	Reduce the duty cycle of the motor operation.
	The motor is encountering an obstacle or excessive friction, which is causing it to stop.	Verify that all components are aligned and running smoothly.
	The load on the motor is exceeding its maximum rating.	Verify that the fabric weight and tube size do not exceed the rating for the motor.
The LED is blue.	The motor is stuck in the bootloader.	Reload firmware to the motor.



### Shade Hardware Accessories

A variety of accessories are available with Crestron® shades. These accessories may be used in circumstances where concealing the shade is desirable or where blackout conditions are required (for example in a movie room).

#### Pockets

A single pocket and a dual pocket are available. Prefabricated pockets reduce the need for custom framing for the shade and allow an easy installation. A single pocket and a dual pocket are available for installations where the pocket cannot be built into the window frame (retrofit applications). The inside of the pocket contains grooved lines for easy drilling and for reducing the need for a center punch. Both pockets are available with a tile lip that supports the edge of a ceiling tile.

#### Single Pocket

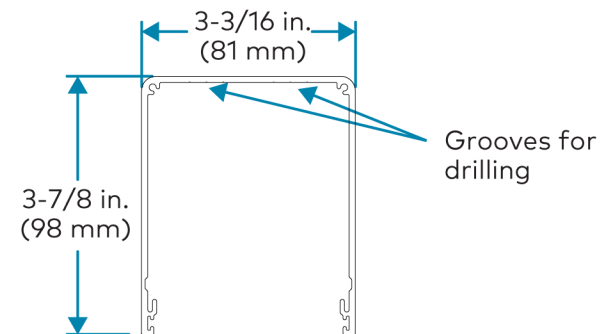

## Shade Motor Bracket Installation and Motor Programming

### Single Pocket with Tile Lip

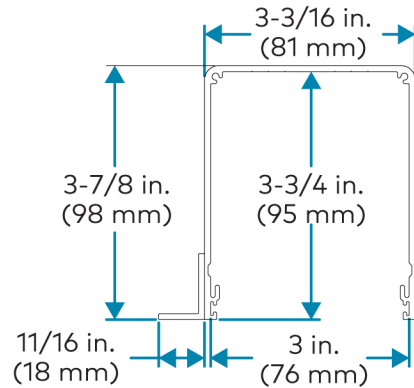

### Dual Pocket with Tile Lip

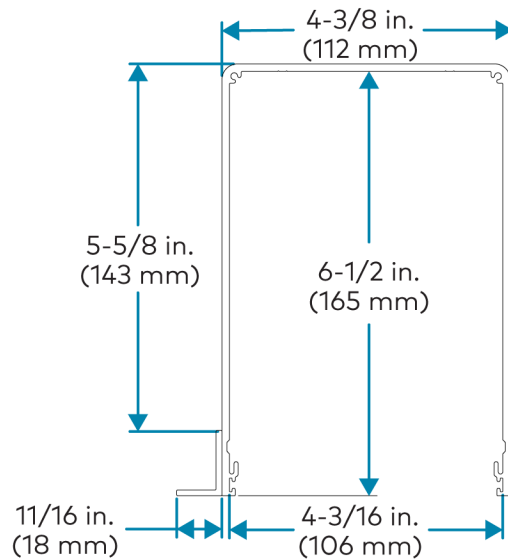

### Top and Back Cover

The top and back cover allows the shade hardware to be concealed when the shade is viewed from above and when the shade is viewed from outside the window. Top and back covers available are for single brackets (CSA-ARCH3-BRKT and CSA-ARCH3-BRKT-MAN) and dual brackets (CSA-ARCH3-BRKT-DUAL).

#### Single Top and Back Cover

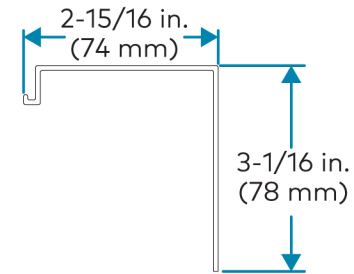

#### Dual Top and Back Cover

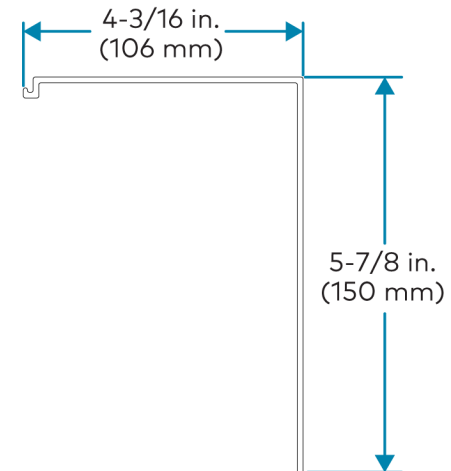

## Shade Motor Bracket Installation and Motor Programming

### Flap

The flap is an accessory that attaches to the inside of the pocket from the room or window side of the pocket. It blocks the opening at the bottom of the pocket so that the shade and hardware cannot be seen. The flap can also attach to a hanger.

#### Flap

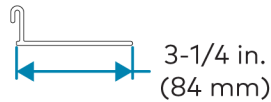

#### Flap Mounting to a Pocket

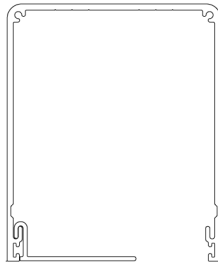

### Hanger

Hangers are designed to mount to the edge of a custom fabricated pocket to hold a flap. The hanger should be mounted inside the pocket. The hanger with a tile lip is used where there is a drop ceiling. The side of the hanger contains a grooved line for easy drilling and for reducing the need for a center punch.

#### Hanger

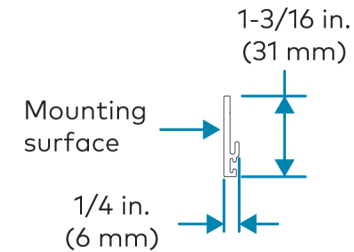

#### Hanger with Tile Lip

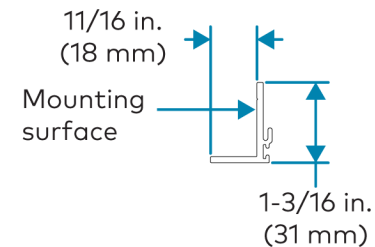

#### Flap Attaching to a Hanger

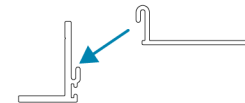

## Shade Motor Bracket Installation and Motor Programming

### Fascia

The fascia is available square or round and is designed to fit single brackets (CSA-ARCH3-BRKT) and dual brackets (CSA-ARCH3-BRKT-DUAL). A smaller square fascia is designed to work with manual shades (CSA-ARCH3-BRKT-MAN) so that the chain can be operated without contacting the fascia. The fascia snaps onto the tabs of the mounting bracket

Square Fascia: CSA-ARCH3-BRKT-MAN



Square and Round Fascias: CSA-ARCH3-BRKT

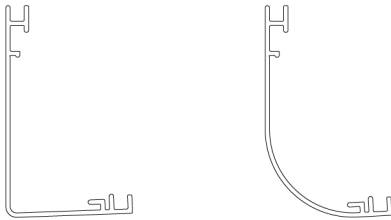

Square and Round Fascias: CSA-ARCH3-BRKT-DUAL

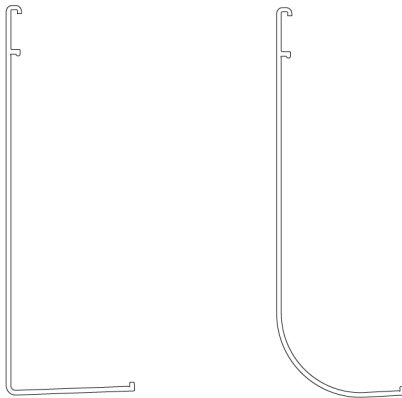

## Shade Motor Bracket Installation and Motor Programming

### End Caps

Bracket end caps are available for use with fascia and the top and back cover. Pocket end caps are available for use with pockets that are not recess-mounted and will be exposed to the room.

There are square or round end caps that are sized to fit single shade brackets (CSA-ARCH3-BRKT and CSA-ARCH3-BRKT-MAN) and dual brackets (CSA-ARCH3-BRKT-DUAL). Round end caps must be used with a round fascia, and square end caps must be used with a square fascia. The end caps snap onto the side of the bracket. Use the printed directions on the end caps to install them in the proper orientation and on the proper side of the shade.

#### Square and Round End Caps: CSA-ARCH3-BRKT and CSA-ARCH3-BRKT-MAN

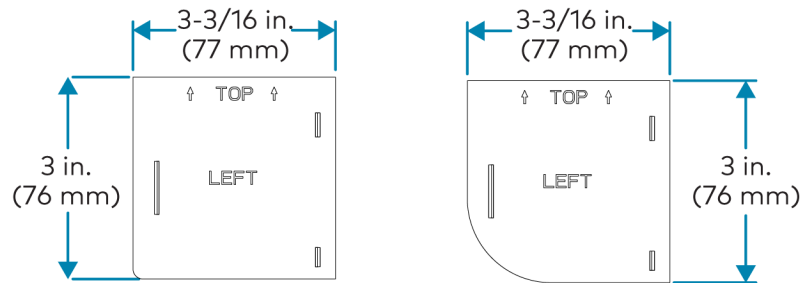

#### Square and Round End Caps: CSA-ARCH3-BRKT-DUAL

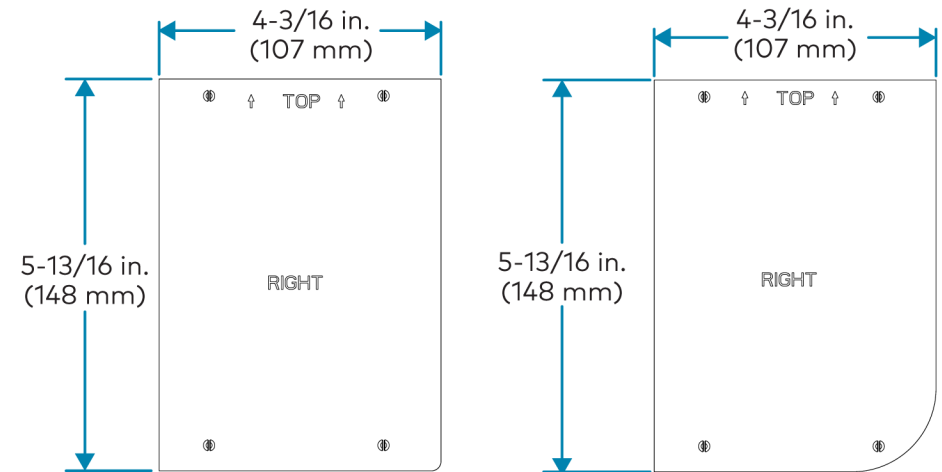

#### Attaching the End Cap to a Single Pocket

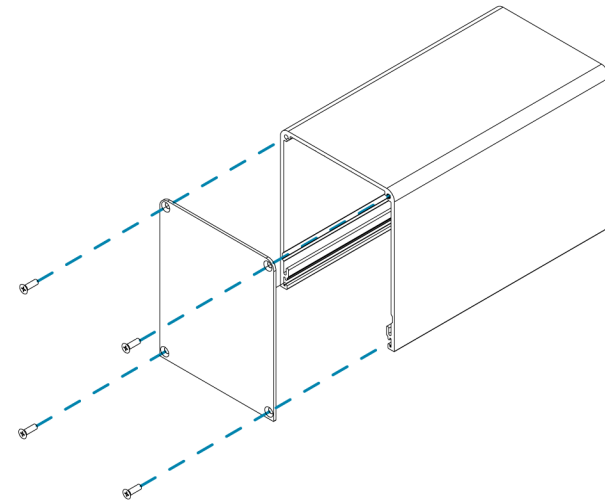

**NOTE:** Use the supplied screws to attach the pocket end caps.

## Shade Motor Bracket Installation and Motor Programming

### Attaching the End Cap to a Dual Pocket

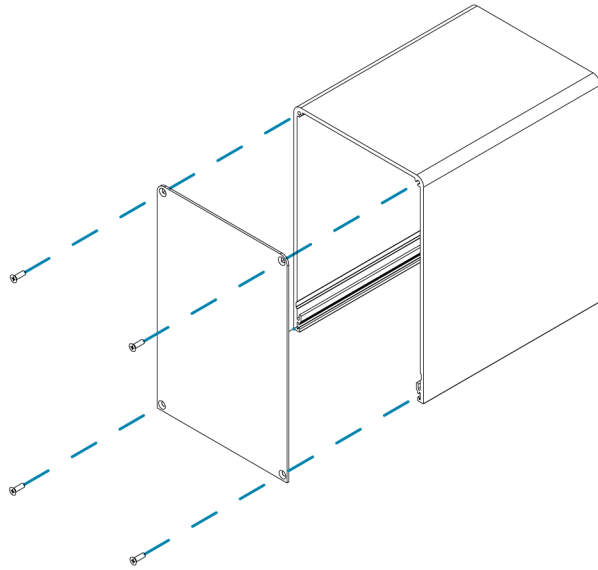

**NOTE:** Use the supplied screws to attach the pocket end caps.

### H-Channel

The H-channel is used between two shades for blackout applications. The face of the H-channel has grooved lines for easy drilling and for reducing the need for a center punch. The opposite side of the H-channel is smooth. Plugs are available to conceal holes in the channel. Use a 3/8-in. drill bit.

### H-Channel

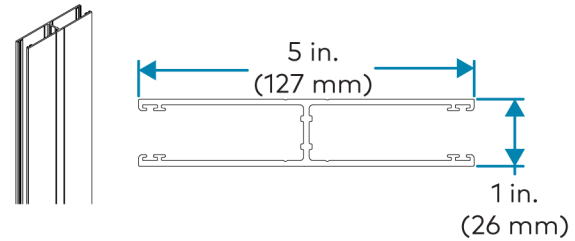

## Shade Motor Bracket Installation and Motor Programming

### U-Channel

The U-channel is used on the sides of shades for blackout applications. The U-channel comes in 2-1/2 in. (64 mm) and 1-1/2 in. (38 mm) widths. The mounting surface of the U-channel has a grooved line for easy drilling and for reducing the need for a center punch. The opposite side of the U-channel is smooth. Plugs are available to conceal holes in the channel. Use a 3/8-in. drill bit.

### U-Channel

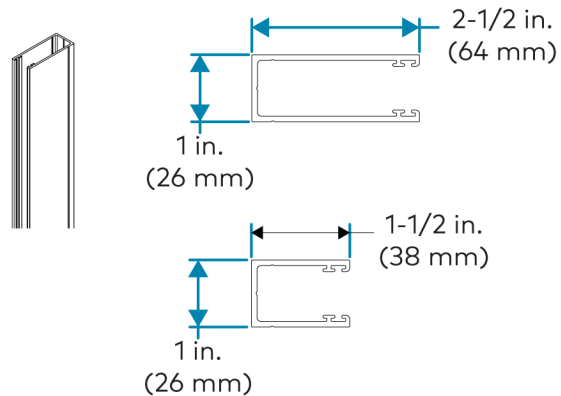

### Channel Cap

H-channels and U-channels come with caps to provide a clean finish on the cut ends. The channel caps can fit the 2-1/2 in. (64 mm) or 1-1/2 in. (38 mm) channel widths. The channel caps press into place. Four channel caps come with the H-channel; two channel caps come with the U-channel.

**CAUTION:** The channel cap must be used on the top of the H-channel or U-channel in order to prevent damage to the shade fabric.

### Channel Cap

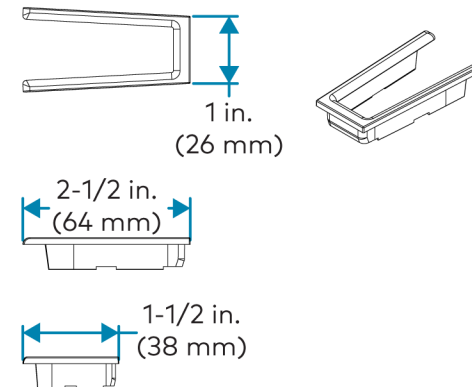

### Inserting the Channel Cap into a U-Channel



## Shade Motor Bracket Installation and Motor Programming

### Sill Angle

The sill angle is used for blackout applications by preventing light leaks along the bottom of the shade. The sill angle is used in conjunction with a blackout hembar. The side of the sill angle contains a grooved line for easy drilling and for reducing the need for a center punch.

#### Sill Angle

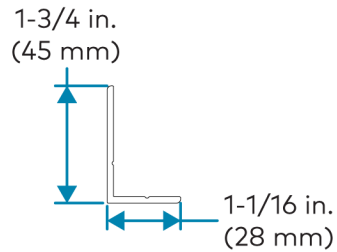

### Wool Pile

The wool pile comes in two sizes. Small wool piles are installed in U- or H-channels and large wool piles are installed in pockets. The wool pile is used to help block light from a room. When ordered with the shade, wool pile is typically preinstalled in the U- or H-channel and pocket.

#### Small Wool Pile

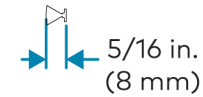

#### Large Wool Pile

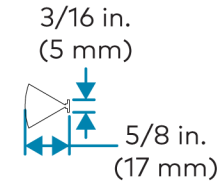



## Shade Motor Bracket Installation and Motor Programming

### Additional Information

#### Original Instructions

The U.S. English version of this document is the original instructions. All other languages are a translation of the original instructions.

Crestron product development software is licensed to Crestron dealers and Crestron Service Providers (CSPs) under a limited nonexclusive, nontransferable Software Development Tools License Agreement. Crestron product operating system software is licensed to Crestron dealers, CSPs, and end-users under a separate End-User License Agreement. Both of these Agreements can be found on the Crestron website at [www.crestron.com/legal/software\\_license\\_agreement](http://www.crestron.com/legal/software_license_agreement).

The product warranty can be found at [www.crestron.com/warranty](http://www.crestron.com/warranty).

The specific patents that cover Crestron products are listed at [www.crestron.com/legal/patents](http://www.crestron.com/legal/patents).

Certain Crestron products contain open source software. For specific information, visit [www.crestron.com/opensource](http://www.crestron.com/opensource).

Crestron, the Crestron logo, Cresnet, infiNET EX, QMT, and Quiet Motor Technology are either trademarks or registered trademarks of Crestron Electronics, Inc. in the United States and/or other countries. Other trademarks, registered trademarks, and trade names may be used in this document to refer to either the entities claiming the marks and names or their products. Crestron disclaims any proprietary interest in the marks and names of others. Crestron is not responsible for errors in typography or photography.

©2020 Crestron Electronics, Inc.

Doc. 7732E

07/17/20