



## Description

The Crestron® 2-Feed, 8-Dimmer Terminal Block and Module (CLTI-2DIMFLV8 and CLXI-2DIMFLV8) are considered single entities and must be used together. They ship separately to permit termination of the field wiring to the terminal block (CLTI) prior to installation of the module (CLXI). The terminal block is designed to terminate the circuit feed (LINE and NEUTRAL) and distribute the controlled circuit (LOAD) to the fixtures. The module connects to the terminal block and performs dimming control of fluorescent ballasts or LED drivers.

The maximum load is 16 A per channel; the maximum load is 32 A total for the CLXI-2DIMFLV8. The CLXI-2DIMFLV8 accepts two 16 A feeds that can be different phases.

There are LEDs on the module to indicate communication to a Cresnet® network, input power to the module, and output power to the load.

The CLTI terminals and CLXI modules are shown in the following illustrations.

CLTI-2DIMFLV8 Terminal Block with Left-Side CLXI-2DIMFLV8 Label

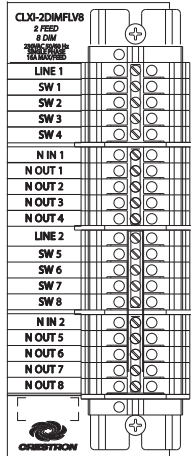

CLXI-2DIMFLV8 Module (Connects to a CLTI-2DIMFLV8)

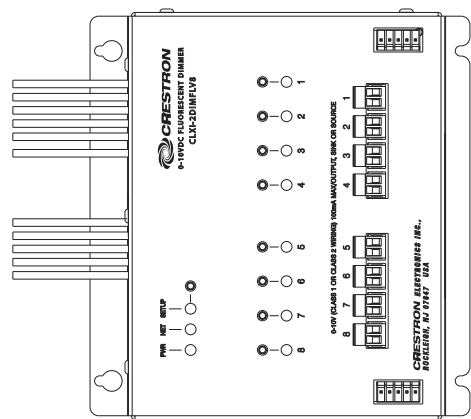

## Specifications

Specifications are listed in the table below.

SPECIFICATION	DETAILS
<b>Load Ratings</b>	
Dimmer Channels	8
Per Channel	4 A
Per Group	Channels 1–4: 16 A Channels 5–8 16 A
Module Total	32 A
0-10 Vdc Output	60 mA Max per output, sink or source
<b>Load Types</b>	
Dimmed Load Types	0-10 V fluorescent ballast or LED driver (4-wire)
Switched Load Types	Incandescent, MLV, ELF, fluorescent ballast, HID
<b>Power Requirements</b>	230 Vac, 50/60 Hz
<b>Environmental</b>	
Temperature	0° to 40 °C (32° to 104 °F)
Humidity	10% to 90% RH (noncondensing)
Heat Dissipation	45 Btu/h
Pollution Degree	2
<b>Voltage Limit for SELV/PELV Circuits</b>	24 V

## Additional Resources

Visit the product page on the Crestron website ([www.crestron.com](http://www.crestron.com)) or scan the QR code to the right for additional information and the latest firmware updates.



CLTI-2DIMFLV8



CLXI-2DIMFLV8

## Installation

A licensed electrician must mount the terminal block and module into a Crestron Automation Enclosure in accordance with all national and local codes.

**CAUTION:** This equipment is for indoor use only and needs to be air cooled. Mount in a well-ventilated area. The ambient temperature must be 0° to 40 °C (32° to 104 °F). The relative humidity must be 10% to 90% (noncondensing).

**NOTE:** The 0–10 V control wires to driver attach directly to the module using 2-pin pluggable connectors. The 0–10 V should be kept clear of the ac wiring.

**NOTE:** The 0–10 V wiring can be run as Class 1 or Class 2.

**NOTE:** For 2-feed systems, the two input lines can be different phases.

**NOTE:** When connecting to an arc fault breaker, ensure the load does not exceed 1,000 watts total. Crestron certified breakers have a 2,000-watt limit.

**NOTE:** Before using the CLXI-2DIMFLV8, ensure the device is using the latest firmware. Check for the latest firmware for the CLXI-2DIMFLV8 at [www.crestron.com/firmware](http://www.crestron.com/firmware). Load the firmware onto the device using Crestron Toolbox™ software.

Install terminal blocks along the left side of single-wide enclosures and along the outside edges (left and right sides) of double-wide enclosures. Install modules along the right side of single-wide enclosures and side-by-side in the center of double-wide enclosures. When installing modules and terminal blocks in a double-wide enclosure, be sure to invert the units on the right side so that they can be properly wired. Refer to the illustrations that follow when considering the location of terminal blocks and modules within an enclosure.

**NOTE:** Modules and terminal blocks must be installed into the lowest available spaces and continue toward the top of the enclosure.

Terminal Block and Module Layout for a Single-Wide Enclosure (CLTI-2DIMFLV8 and CLXI-2DIMFLV8 Shown)

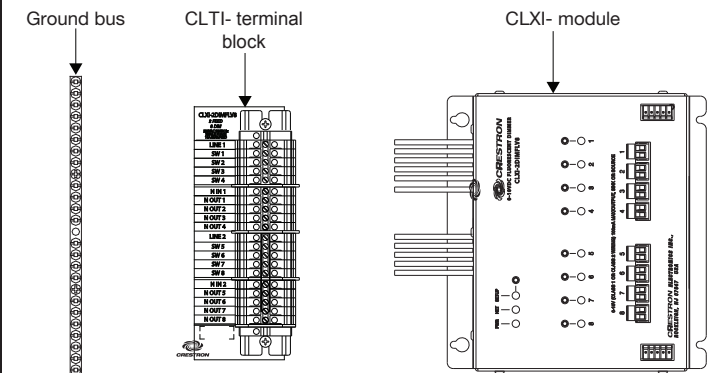

Terminal Block and Module Layout for a Double-Wide Enclosure (CLTI-2DIMFLV8 and CLXI-2DIMFLV8 Shown)

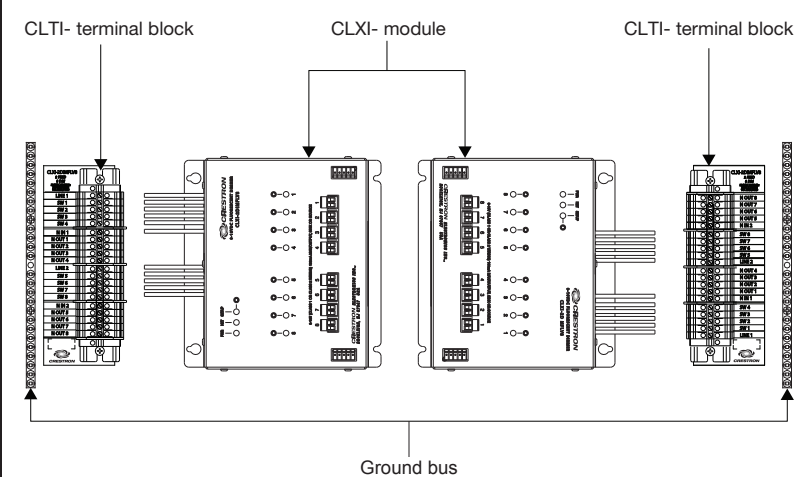

**NOTE:** Unless otherwise indicated, the lighting system specified in this guide is modular, requiring assembly in the field by a licensed electrician in accordance with all national and local codes.

If an assembled UL Listed panel is required, Crestron offers this service through its UL Listed panel shop. This includes complete in-factory system configuration and assembly by Crestron for an additional fee.

### Terminal Block Installation and Field Wiring

Terminal block installation requires installation of the supplied adhesive label and the terminal block. The adhesive label provides the labeling for each terminal in the terminal block and is designed to accommodate installation into the left or right side of a cabinet. Refer to the illustrations that follow for details.

**WARNING:** The CLXI-2DIMFLV8 may be powered from multiple circuit breakers.

**NOTE:** Both left-side and right-side adhesive wiring labels are provided. The left-side labels are used in both single- and double-wide enclosures. The right-side labels are used only in double-wide enclosures.

1. Remove the backing from the left- or right-side adhesive wiring label.
2. Apply the adhesive label by aligning the holes in the label with the holes on the Crestron Automation Enclosure where the terminal block is to be mounted. The wiring label lies beneath the terminal block.
3. Use the two supplied self-tapping Phillips pan head screws (8B x 1/4-inch length) to secure the terminal block to the Crestron Automation Enclosure.

**CAUTION:** Bypass jumpers are provided to allow testing of circuits and to protect the module during installation. When properly secured by five screws, each of the two jumpers on the black and red sections of the terminal block shorts the line in to dim out so that the circuit is energized. Do not remove any bypass jumpers until all feed and load wiring has been completed, the circuit has been tested for electrical faults, and the module has been installed. Refer to “Module Installation and Wiring” for details.

Furthermore, the two jumpers on the white sections of the terminal block tie the neutral ins to the neutral outs. Never remove these jumpers.

**NOTE:** Use copper conductors only, rated 75 °C or greater.

4. Turn off the circuit breakers.

5. Connect the circuit feed (line and neutral) and controlled circuit (load) wires to the terminal block per the markings provided on the wiring label. Terminal blocks accept one 14–10 AWG wire. Strip the wires to 1/2 inch (13 millimeters). Tighten the terminal blocks to 9 in-lb.
6. Grounding terminal blocks are available in the cabinet for termination of ground wires. Tighten to 35 in-lb (14–10 AWG), 40 in-lb (8 AWG), or 45 in-lb (6–4 AWG).
7. Test each circuit for electrical faults by turning on each of the circuit breakers and checking that the breakers do not trip and that power is delivered to the proper loads.

Wiring the Terminal Block to the Feed and Load(s) (Single-Wide and Left-Side Double-Wide Enclosures)

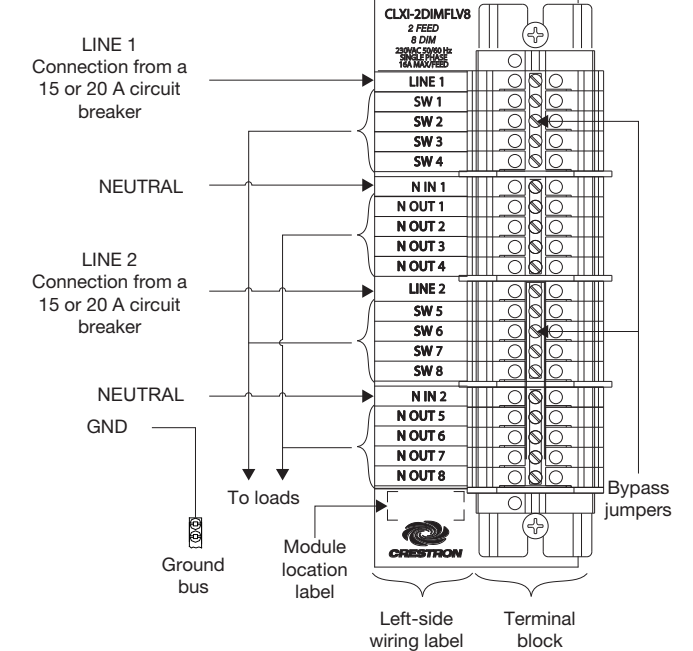

Wiring the Terminal Block to the Feed and Load(s) (Right-Side Double-Wide Enclosures)

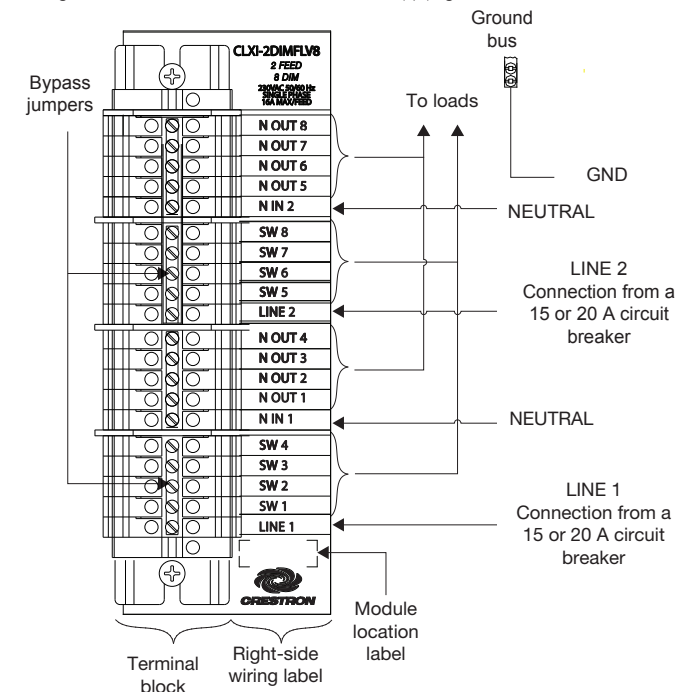

### Module Installation and Wiring

**CAUTION:** The module contains electrostatic sensitive devices (ESDs); the unit must be handled from the metal chassis. Do not touch the PC board or components.

**NOTE:** Install the modules after the enclosure has been completely wired. Refer to “Terminal Block Installation and Field Wiring” for details.

Install and wire the module.

1. Use the four supplied self-tapping Phillips pan head screws (8B x 1/4-inch length) to secure the module to the enclosure.

- Connect the wires from the module to the terminal block. Each wire exits the module directly in line with, and is the same color as, the terminal to which it should be connected. Wires are prestripped to 1/2 inch (13 millimeters). Tighten to 9 in-lb.
- If the module is being installed above another module within the enclosure, attach the supplied module interconnect cable between the two modules. The illustration that follows shows the area within a double-wide enclosure where the corners of four modules meet.

**NOTE:** One wire on the module interconnect cable may be a different color from the rest. The color has no bearing on its orientation during installation.

Using Module Interconnect Cable to Wire One Module to Another

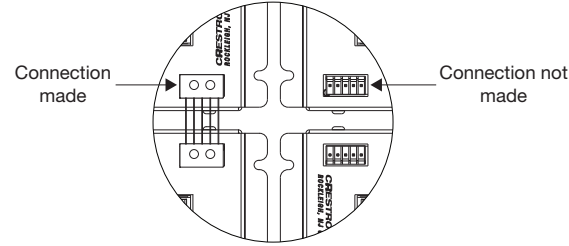

- Turn on the circuit breakers and verify that the green PWR LED on the module lights, the breakers do not trip, and power is delivered to the loads.
- Turn off the circuit breakers.

**NOTE:** Before removing the bypass jumpers, make sure to properly connect and program the control system that provides functionality to the system.

- Remove the bypass jumpers on the black and red sections of the terminal block. The jumpers on the white sections of the terminal block must remain installed.

Wiring the Terminal Block to the Module (Single-Wide and Left-Side Double-Wide Enclosures)

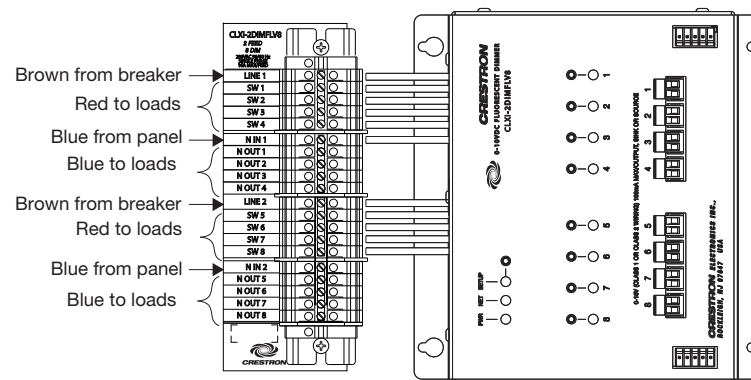

Removing the Line Jumpers after Testing (Single-Wide and Left-Side Double-Wide Enclosures and Right-Side Mounted CLTI-2DIMFLV8 Shown)

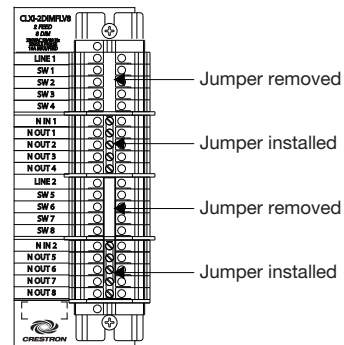

- Turn on the circuit breakers.

**NOTE:** Power must be supplied to LINE 1 for the module to communicate with the control system or for any of the circuits to operate.

- If the program is not yet running, test the loads using Local mode.

## Wire the Ballast

**NOTE:** When making 0-10V connections, strip the ends of the wires approximately 7/16 in (11 mm). Use care to avoid nicking the conductors. Tighten the connector to 5 in-lb (0.5 to 0.6 N-m). The wire gauge should be 14 to 26 AWG.

Make the neutral, switched power, +, and - connections to the ballast.

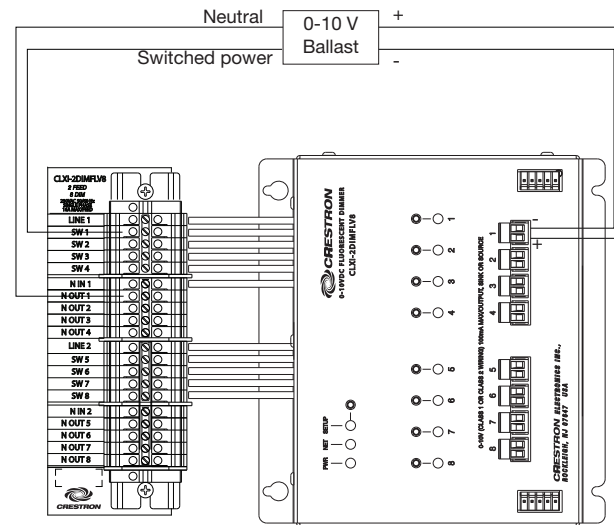

## Local Control

Use the individual output controls to test the functionality of each output. Press the button above the 1-8 LEDs to turn the load on (100%) and off. Press and hold the button to cycle-dim the load. The LED lights red to indicate that the load is on.

When TSID is active, press the SETUP button to identify the device.

The POWER LED lights to indicate that the device is receiving power.

The NET LED lights to indicate that the device is being polled over Cresnet in the past 2 seconds.

## Troubleshooting

The following provides corrective actions for possible trouble situations. If further assistance is required, please contact a Crestron customer service representative.

CLXI-2DIMFLV8 Troubleshooting

TROUBLE	POSSIBLE CAUSE(S)	CORRECTIVE ACTION
The connected loads are not on. No LEDs are lit on the module.	LINE1 breaker is off.	Check the breaker.
	The internal fuse for LINE 1 may have blown due to a short circuit on a switched output.	Find and correct the short. Contact Crestron customer support.
The loads connected to channels 5-8 do not turn on.	LINE 2 breaker is off	Check the breaker.
	The internal fuse for LINE 2 may have blown due to a short circuit on a switched output.	Find and correct the short. Contact Crestron customer support.
The loads on a specific channel stay at a dim level.	The 0-10 V wiring to the ballast or driver may be shorted.	Check the wiring.
	The 0-10 V wiring may be reversed.	Check the wiring.
	Two or more 0-10 V wires may be shorted to ground.	Unplug the 0-10 V connections to identify the faulty wire run. Check the wiring.
The SETUP LED blinks error code 2-1 (2 blinks, pause, 1 blink, long pause, then repeat).	One or more 0-10 V outputs are shorted	Unplug the 0-10 V connections to identify the faulty wire run. Check the wiring.

Perform the following basic steps to troubleshoot 0-10 V driver or ballast issues.

- Apply bypass jumpers so that all fixtures are energized.
- Disconnect the purple and gray wires (0-10 V control) from the module. The fixtures should go to full brightness. If fixtures do not go to full brightness, then one of the following has occurred:
  - There is a short in the wiring (purple to gray).
  - A ballast or driver has the purple and gray wires reversed.
  - One or more purple and one or more gray wires are shorted to ground.
  - There is a faulty driver or ballast.
- Create a short by connecting the purple and gray wires. The fixtures should go to their minimum brightness. If a fixture does not dim down, then one of the following has occurred:
  - There is a break in the gray or purple control wires.
  - There is a faulty driver or ballast.

As of the date of manufacture, the device has been tested and found to comply with specifications for CE marking.



The product warranty can be found at [www.crestron.com/warranty](http://www.crestron.com/warranty).

The specific patents that cover Crestron products are listed at [patents.crestron.com](http://patents.crestron.com).

Certain Crestron products contain open source software. For specific information, please visit [www.crestron.com/opensource](http://www.crestron.com/opensource).

Crestron, the Crestron logo, Cresnet, and Crestron Toolbox are either trademarks or registered trademarks of Crestron Electronics, Inc. in the United States and/or other countries. Other trademarks, registered trademarks, and trade names may be used in this document to refer to either the entities claiming the marks and names or their products. Crestron disclaims any proprietary interest in the marks and names of others. Crestron is not responsible for errors in typography or photography.

This document was written by the Technical Publications department at Crestron.

©2017 Crestron Electronics, Inc.

Crestron Electronics, Inc.  
15 Volvo Drive Rockleigh, NJ 07647  
Tel: 888.CRESTRON  
Fax: 201.767.7576  
[www.crestron.com](http://www.crestron.com)

Installation Guide - DOC. 7942B

(2047539)

03.17

Specifications subject to change without notice.