

# Crestron **HBK-6000 & SMK-6000** Hatchback and Swivel Mount Kits Installation Guide



This document was prepared and written by the Technical Documentation department at:



Crestron Electronics, Inc.  
15 Volvo Drive  
Rockleigh, NJ 07647  
1-888-CRESTRON

# Hatchback and Swivel Mount Kits: HBK-6000 & SMK-6000

## Description

The Hatchback and Swivel Mount Kits, HBK-6000 and SMK-6000 (each sold separately), are designed for attachment to the Crestron® TPS-6000, TPS-5000, and TPS-4500 tilt touchpanels.

The HBK-6000 hatchback is a sleekly designed rear-cover option that provides cable, management, wire strain relief, and prevents unauthorized users from disconnecting the touchpanel. The wire exit hole at the rear of the HBK-6000 is sized to accommodate all cables that would typically be connected to the touchpanel. These include the Crestron-furnished 10-position, Siamese, or Triamese network cable; an off-the-shelf DB15HD VGA cable, a CAT5 Ethernet cable, and a DC power cable from an optional PW-2420RU power supply.

The SMK-6000 swivel mount accessory reduces the chance of theft while improving viewing convenience. The base rotates 330 degrees, mounts on the desktop, in a lectern, or on a conference table, and accommodates surface thicknesses from 3/4-inch minimum to 1 3/8-inches maximum, using the hardware provided. The swivel mount kit includes the same rear cover as the HBK-6000 option, which covers the cable connections. Routing the cables down through the center of the swivel assembly keeps the cables completely hidden from the work surface.

The SMK-6000 should not be used in combination with the TPS-XVGA RGB Graphics Card, as it does not accommodate the size and bend-radius of a typical off-the-shelf RGBHV cable. Instead, the TPS-XVGA-BV RGB Graphics Card w/Balanced Video should be used. The TPS-XVGA-BV includes a special Triamese cable, which is compact and flexible enough to use with the SMK-6000.

## Supplied Hardware

The hardware supplied in the kits is listed in the following table.

*Supplied Hardware of the HBK-6000 and SMK-6000 Hatchback and Swivel Mount Kits*

HBK-6000	SMK-6000*
One (1) Metal Bracket	One (1) Swivel Mount Assembly
One (1) Plastic Cover	One (1) Metal Bracket
Four (4) Screws 4-40 X 3/16 inch	One (1) Metal Plate
	One (1) Plastic Cover
	Sixteen (16) Screws
	(4) 4-40 X 3/16-inch
	(4) 6-32 X 1/4-inch
	(4) 8-32 X 5/8-inch
	(4) 8-32 X 1-inch

\* The SMK-6000 mounting kit includes a template for preparing the mounting surface.

## Installation

This section provides an installation procedure for each kit. The only tools required are #1, #2, and #3 Phillips screwdrivers.

### HBK-6000 Assembly/Installation Procedure

To attach the HBK-6000 Hatch Back Kit to the TPS-4500, -5000, or -6000 Touchpanel, refer to the illustration below and perform the procedures that follow.

#### *HBK-6000 Assembly View*

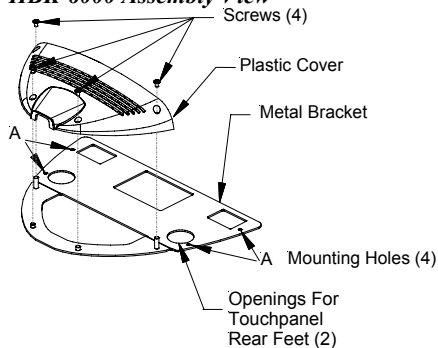

1. If necessary, use the touchpanel position lock buttons to adjust the display to the maximum (most vertical/upright) angle.
2. Place the touchpanel face down on a padded surface to prevent damage to the display screen.
3. Remove the four screws from the bottom rear of the touchpanel that correspond to the mounting holes (A) in the metal bracket.
4. Position the metal bracket on the touchpanel base (mounting holes should align, touchpanel feet should protrude through openings provided, and standoff posts should point toward the touchpanel). Secure the metal bracket to the touchpanel using the four screws removed in step 3.
5. With the touchpanel in its normal position, make certain cable connections are secure, put the plastic cover in position with the cables routed through the rear opening. Secure the cover to the metal bracket using the four # 4-40X 3/16-inch screws supplied.

### SMK-6000 Assembly/Installation Procedure

To attach the SMK-6000 Swivel Mount Kit to the TPS-4500, -5000, or -6000 Touchpanel and install the assembly on a suitable mounting surface, refer to the following illustrations and perform the associated procedures.

1. Prepare the mounting surface using the template provided with the kit. The center hole for the swivel assembly should be 2.5-inches minimum; 2.6-inches maximum. Make certain to observe the “FRONT” position when drilling the four holes for the swivel assembly standoff posts.
2. If necessary, to prevent errors when reconnecting, label and disconnect any cables connected to the touchpanel.
3. If necessary, use the touchpanel position lock buttons to adjust the display to the maximum (most vertical/upright) angle.

4. Place the touchpanel face down on a padded surface to prevent damage to the display screen.
5. Refer to the following illustration and remove the six screws from the bottom rear of the touchpanel that correspond to the mounting holes (A) in the metal bracket of the kit.

**SMK-6000 Swivel Mount Kit Assembly Diagram**

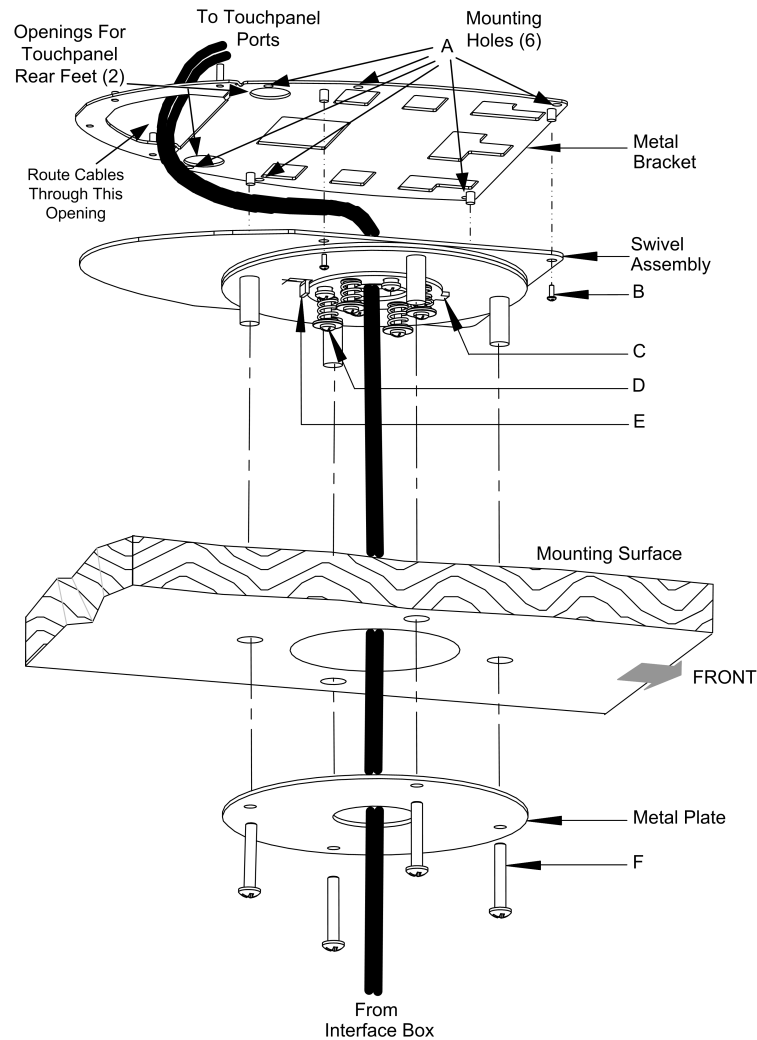

6. Place the metal bracket on the touchpanel base (mounting holes should align, touchpanel feet should protrude through openings provided, and standoff posts for the rear cover should point toward the touchpanel). Secure the metal bracket to the touchpanel using the six screws removed in step 5.
7. Route the cables from the interface box up through the Metal Plate, through the mounting surface, and through the Swivel Assembly, then through the area of the bracket shown in the figure, and connect to the appropriate touchpanel ports. Route the cables carefully to avoid chafing.
8. Being careful to avoid damage to the cables, attach the Swivel Assembly to the Metal Bracket, using the supplied four #6-32 X 1/4 inch screws **B** through the holes in the swivel assembly into the standoff posts on the bracket. Make certain the cables are not twisted or crimped and have sufficient slack at the port connections before fully tightening the screws.

9. Make certain tab **C** is positioned to the front of the swivel assembly, and that it is directly opposite bent tab **E**, and place the touchpanel and swivel mount assembly down on the Mounting Surface.
10. Hold the Metal Plate in position under the mounting surface and secure the assembly in place using the #8-32 screws **F** provided (use the 5/8-inch screws for surfaces 3/4-inch to 1 1/8-inches thick; use the 1-inch screws for surfaces 1 1/8 to 1 3/8 inches thick). Use screws **D** to adjust tension of the swivel assembly.
11. Refer to the following illustration, put the plastic cover in position and secure to the metal bracket using the four #4-40 X 3/16-inch screws supplied.

*SMK-6000 Swivel Mount Kit Rear Cover Assembly*

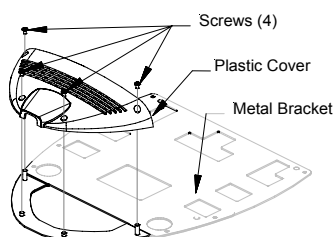

---

## Further Inquiries

If you cannot locate specific information or have questions after reviewing this guide, please take advantage of Crestron's award winning customer service team by calling the Crestron corporate headquarters at 1-888-CRESTRON [1-888-273-7876]. For assistance in your local time zone, refer to the Crestron website ([www.crestron.com](http://www.crestron.com)) for a listing of Crestron worldwide offices.

You can also log onto the online section of the Crestron website ([www.crestron.com](http://www.crestron.com)) to ask questions about Crestron products. First-time users will need to establish a user account to fully benefit from all available features.

As of the date of manufacture, the HBK-6000 and SMK-6000 have been tested and found to comply with specifications for CE marking.



---

## Future Updates

As Crestron adds improvements to the HBK-6000 or SMK-6000, additional information may be made available as manual updates. These updates are solely electronic and serve as intermediary supplements prior to the release of a complete technical documentation revision.

Check the Crestron website ([www.crestron.com](http://www.crestron.com)) periodically for manual update availability and its relevance. Updates are available from the Download | Product Manuals section and are identified as an “Addendum” in the Download column.

---

## Return and Warranty Policies

### Merchandise Returns / Repair Service

1. No merchandise may be returned for credit, exchange, or service without prior authorization from CRESTRON. To obtain warranty service for CRESTRON products, contact the factory and request an RMA (Return Merchandise Authorization) number. Enclose a note specifying the nature of the problem, name and phone number of contact person, RMA number, and return address.
2. Products may be returned for credit, exchange, or service with a CRESTRON Return Merchandise Authorization (RMA) number. Authorized returns must be shipped freight prepaid to CRESTRON, 6 Volvo Drive, Rockleigh, N.J., or its authorized subsidiaries, with RMA number clearly marked on the outside of all cartons. Shipments arriving freight collect or without an RMA number shall be subject to refusal. CRESTRON reserves the right in its sole and absolute discretion to charge a 15% restocking fee, plus shipping costs, on any products returned with an RMA.
3. Return freight charges following repair of items under warranty shall be paid by CRESTRON, shipping by standard ground carrier. In the event repairs are found to be non-warranty, return freight costs shall be paid by the purchaser.

### CRESTRON Limited Warranty

CRESTRON ELECTRONICS, Inc. warrants its products to be free from manufacturing defects in materials and workmanship under normal use for a period of three (3) years from the date of purchase from CRESTRON, with the following exceptions: disk drives and any other moving or rotating mechanical parts, pan/tilt heads and power supplies are covered for a period of one (1) year; touchscreen display and overlay components are covered for 90 days; batteries and incandescent lamps are not covered.

This warranty extends to products purchased directly from CRESTRON or an authorized CRESTRON dealer. Purchasers should inquire of the dealer regarding the nature and extent of the dealer's warranty, if any.

CRESTRON shall not be liable to honor the terms of this warranty if the product has been used in any application other than that for which it was intended, or if it has been subjected to misuse, accidental damage, modification, or improper installation procedures. Furthermore, this warranty does not cover any product that has had the serial number altered, defaced, or removed.

This warranty shall be the sole and exclusive remedy to the original purchaser. In no event shall CRESTRON be liable for incidental or consequential damages of any kind (property or economic damages inclusive) arising from the sale or use of this equipment. CRESTRON is not liable for any claim made by a third party or made by the purchaser for a third party.

CRESTRON shall, at its option, repair or replace any product found defective, without charge for parts or labor. Repaired or replaced equipment and parts supplied under this warranty shall be covered only by the unexpired portion of the warranty.

Except as expressly set forth in this warranty, CRESTRON makes no other warranties, expressed or implied, nor authorizes any other party to offer any warranty, including any implied warranties of merchantability or fitness for a particular purpose. Any implied warranties that may be imposed by law are limited to the terms of this limited warranty. This warranty statement supercedes all previous warranties.

#### Trademark Information

*All brand names, product names, and trademarks are the sole property of their respective owners. Windows is a registered trademark of Microsoft Corporation. Windows95/98/Me/XP and WindowsNT/2000 are trademarks of Microsoft Corporation.*



**Crestron Electronics, Inc.**  
15 Volvo Drive Rockleigh, NJ 07647  
Tel: 888.CRESTRON  
Fax: 201.767.7576  
[www.crestron.com](http://www.crestron.com)

---

**Installation Guide – DOC. 6111**  
**09.02**

Specifications subject to  
change without notice.