

Description

The PMK-3100L is a pre-construction mount kit for the Crestron Isys[®] TPS-3100L series of wall mounted touchpanels. The PMK-3100L is used for installation on a stud. For custom touchpanel placement without a stud, use the WMKT-3100L or the WMKM-3100L. The PMK-3100L includes an 18 AWG bus wire to secure touchpanel cabling prior to drywall installation and to avoid damaging the cables when the opening is routed. Refer to the physical views (bottom, side, and front) of the PMK-3100L, shown after this paragraph. The table that follows lists all parts included with the PMK-3100L.

NOTE: This mounting kit is to be used only with the TPS-3100L series of touchpanels.

PMK-3100L Physical Views

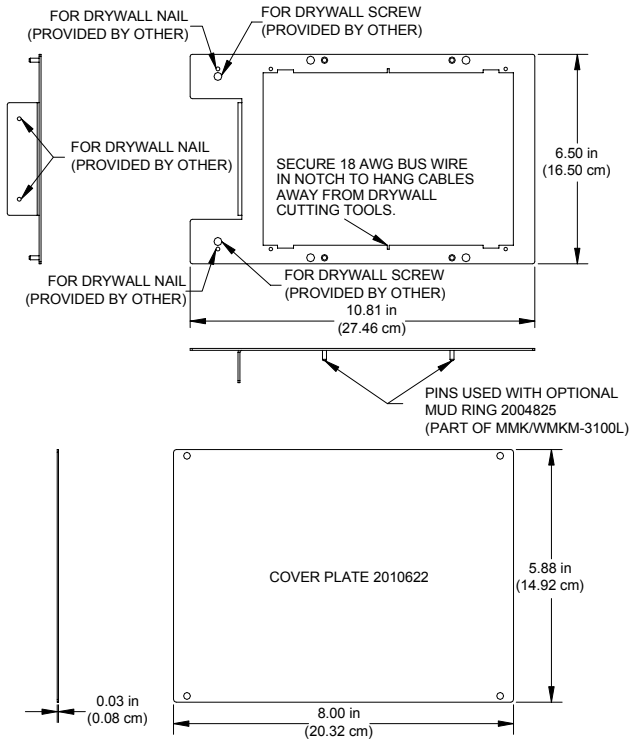

Supplied Components

DESCRIPTION	PART NUMBER	QUANTITY
Metal, Plate, Mounting	2010617	1
Metal, Plate, Cover	2010622	1
Screw, #6-32, 1-1/2"L, Pan, Phil	2007254	4
Jumper wire, 12"L, 18AWG, Black	2007838	1

Installation

The PMK-3100L consists of a single metal plate, which fastens to the stud of a framed wall prior to hanging

Crestron Electronics, Inc.
 15 Volvo Drive Rockleigh, NJ 07647
 Tel: 888.CRESTRON
 Fax: 201.767.7576
 www.crestron.com

drywall (shown after this paragraph). Standard drywall nails or screws to attach the PMK-3100L are not supplied (length can vary).

Metal Plate Secured to Stud

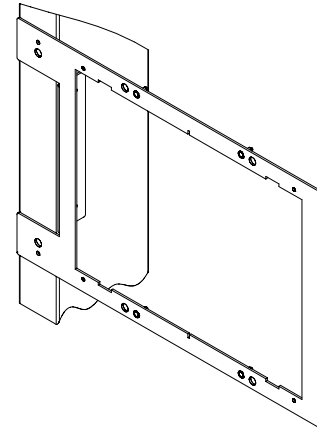

The plate is designed to provide the necessary support for a single touchpanel and can mount to the right or left side of a stud. Confirm that the PMK-3100L is level before application of drywall. A rectangular opening with the dimensions shown in the illustration after this paragraph must be made in the drywall. Verify that the opening exposes the #6-32 tapped holes in each corner.

Dimensions for Drywall Cutout

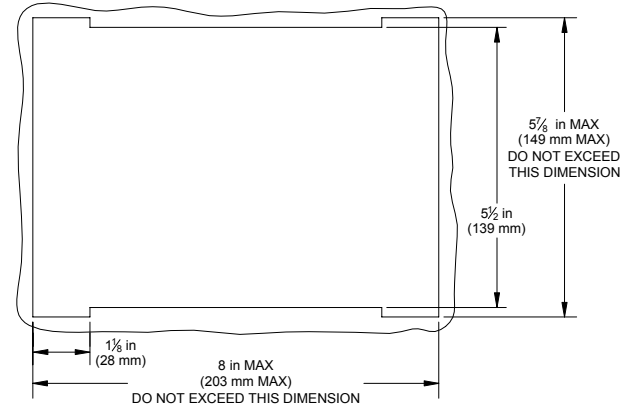

If the opening for the touchpanel in the drywall is too large, two pre-construction accessories are available to make adjustments. Use the optional TMK-3100L (Trim Ring Kit) to provide a smooth edge at the opening. This option provides a finished appearance and is preferred when wallpaper is hung. Use the optional MMK-3100L (Mud Ring Kit) to fill in larger irregularities around the opening (requires plastering).

Complete the installation by either installing the touchpanel, leaving the hole open (if permitted by local building codes), or installing the supplied cover plate with the included #6-32 x 1 1/2" screws (shown after this

paragraph). If the touchpanel is to be installed, refer to the latest revision of the TPS-3100L Operations & Installation Guide (Doc. 6291) for installation instructions.

Attaching Cover

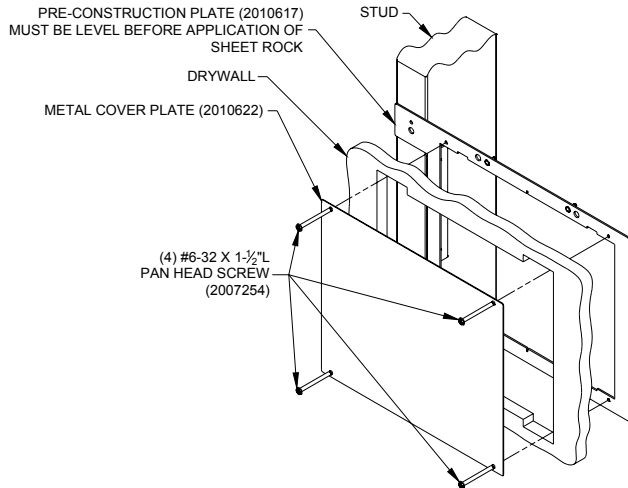

Further Inquiries

If after reviewing this sheet, you cannot locate specific information or have questions, please take advantage of Crestron's award winning customer service team by calling:

- In the US and Canada, call Crestron's corporate headquarters at 1-888-CRESTRON [1-888-273-7876].
- In Europe, call Crestron International at +32-15-50-99-50.
- In Asia, call Crestron Asia at +852-2341-2016.
- In Latin America, call Crestron Latin America at +5255-5093-2160.
- In Australia and New Zealand, call Crestron Control Solutions at +61-2-9737-8203.

You can also log onto the online help section of the Crestron website (www.crestron.com) to ask questions about Crestron products. First-time users will need to establish a user account to fully benefit from all available features.

As of the date of manufacture, the PMK-3100L has been tested and found to comply with specifications for CE marking.



Return and Warranty Policies

Merchandise Returns / Repair Service

1. No merchandise may be returned for credit, exchange, or service without prior authorization from CRESTRON. To obtain warranty service for CRESTRON products, contact the factory and request an RMA (Return Merchandise Authorization) number. Enclose a note specifying the nature of the problem, name and phone number of contact person, RMA number, and return address.
2. Products may be returned for credit, exchange, or service with a CRESTRON Return Merchandise Authorization (RMA) number. Authorized returns must be shipped freight prepaid to CRESTRON, 6 Volvo Drive, Rockleigh, N.J., or its authorized subsidiaries, with RMA number clearly marked on the outside of all cartons. Shipments arriving freight collect or without an RMA number shall be subject to refusal. CRESTRON reserves the right in its sole and absolute discretion to charge a 15% restocking fee, plus shipping costs, on any products returned with an RMA.
3. Return freight charges following repair of items under warranty shall be paid by CRESTRON, shipping by standard ground carrier. In the event repairs are found to be non-warranty, return freight costs shall be paid by the purchaser.

CRESTRON Limited Warranty

CRESTRON ELECTRONICS, Inc. warrants its products to be free from manufacturing defects in materials and workmanship under normal use for a period of three (3) years from the date of purchase from CRESTRON, with the following exceptions: disk drives and any other moving or rotating mechanical parts, pan/tilt heads and power supplies are covered for a period of one (1) year; touchscreen display and overlay components are covered for 90 days; batteries and incandescent lamps are not covered.

This warranty extends to products purchased directly from CRESTRON or an authorized CRESTRON dealer. Purchasers should inquire of the dealer regarding the nature and extent of the dealer's warranty, if any.

CRESTRON shall not be liable to honor the terms of this warranty if the product has been used in any application other than that for which it was intended, or if it has been subjected to misuse, accidental damage, modification, or improper installation procedures. Furthermore, this warranty does not cover any product that has had the serial number altered, defaced, or removed.

This warranty shall be the sole and exclusive remedy to the original purchaser. In no event shall CRESTRON be liable for incidental or consequential damages of any kind (property or economic damages inclusive) arising from the sale or use of this equipment. CRESTRON is not liable for any claim made by a third party or made by the purchaser for a third party.

CRESTRON shall, at its option, repair or replace any product found defective, without charge for parts or labor. Repaired or replaced equipment and parts supplied under this warranty shall be covered only by the unexpired portion of the warranty.

Except as expressly set forth in this warranty, CRESTRON makes no other warranties, expressed or implied, nor authorizes any other party to offer any warranty, including any implied warranties of merchantability or fitness for a particular purpose. Any implied warranties that may be imposed by law are limited to the terms of this limited warranty. This warranty statement supercedes all previous warranties.

Trademark Information

All brand names, product names, and trademarks are the sole property of their respective owners. Windows is a registered trademark of Microsoft Corporation. Windows95/98/Me/XP and WindowsNT/2000 are trademarks of Microsoft Corporation.