

IDOC-PAD-LCA-DSC/DSWC CONVERSION KIT

Conversion Kit for IDOC-PAD-LCA-DSC and IDOC-PAD-LCA-DSWC
Installation Guide



Description

The IDOC-PAD-LCA-DSC/DSWC_CONVERSION_KIT is used to make the Crestron® IDOC-PAD-LCA-DSC and IDOC-PAD-LCA-DSWC (both referred to hereafter as "iPanel®") compatible with the iPad Air® 2. The kit can be installed at any time.

NOTE: Once installed, first generation iPad Air models can no longer be placed in the iPanel.

Additional Resources

Visit the product page on the Crestron website (www.crestron.com) for information and the latest firmware updates. Use a QR reader application on your mobile device to scan the QR code.



Installation

Preparation

The kit consists of two self-adhesive, plastic rails that are installed into the iPanel. Perform the following procedure to install the rails.

1. If installed, remove the iPad® from the iPanel.

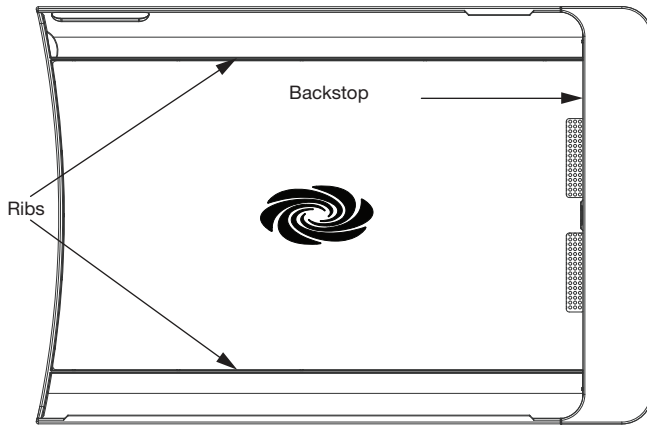

2. Clean the surfaces of the cradle's ribs using the supplied alcohol wipe. Make sure the surfaces are fully dried before continuing to the next step.

3. Remove the adhesive backing from a rail, and without allowing the adhesive surface to touch the rib, place the edge of the rail against the backstop inside the cradle with the adhesive facing the outside of the rib as shown below.

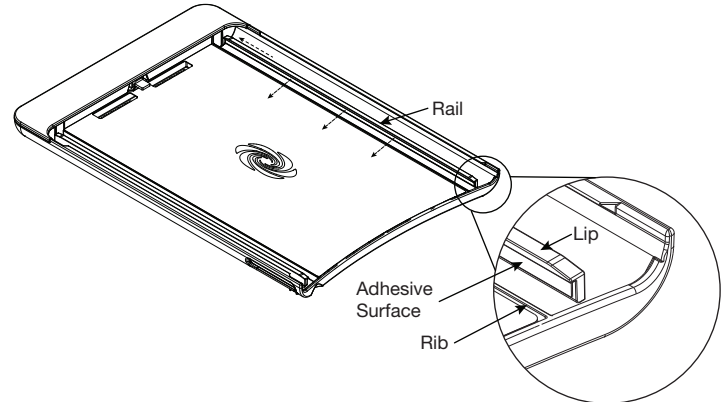

4. Slide the rail along the bottom of the cradle towards the outside of the rib until the adhesive backing makes contact with the rib.
5. Press the rail's lip down to the top of the rib, and ensure there is no gap between the bottom of the rail's lip and the top of the cradle's rib. If there is, carefully remove the rail and reinstall.

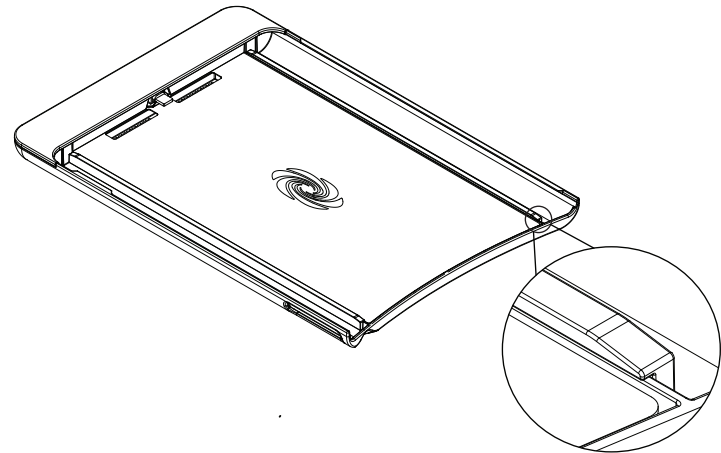

6. Apply pressure along the length of the back of the rail to make solid contact between the rib and adhesive backing.
7. Repeat steps 3-6 for the other rail.

As of the date of manufacture, the product has been tested and found to comply with specifications for CE marking.



The product warranty can be found at www.crestron.com/warranty.

The specific patents that cover Crestron products are listed at patents.crestron.com.

Crestron, the Crestron logo, and iPanel are either trademarks or registered trademarks of Crestron Electronics, Inc. in the United States and/or other countries. iPad and iPad Air are either trademarks or registered trademarks of Apple, Inc. in the United States and/or other countries. Other trademarks, registered trademarks, and trade names may be used in this document to refer to either the entities claiming the marks and names or their products. Crestron disclaims any proprietary interest in the marks and names of others. Crestron is not responsible for errors in typography or photography.

This document was written by the Technical Publications department at Crestron.

©2015 Crestron Electronics, Inc.

Crestron Electronics, Inc.
15 Volvo Drive Rockleigh, NJ 07647
Tel: 888.CRESTRON
Fax: 201.767.7576
www.crestron.com

Installation Guide - DOC. 7805A
(2044334)
07.15

Specifications subject to
change without notice.