

DM NUX USB over Network Wall Plates with Routing

The DM NUX USB over Network Wall Plates with Routing ([DM-NUX-L2-1G](#) and [DM-NUX-R2-1G](#)) deliver reliable, high-speed USB signal extension and routing for USB 1.0, 1.1, and 2.0 devices throughout a home, business, or campus for distances up to 330 ft (100 m). Featuring Virtual Hub capabilities, five DM-NUX-R2-1G endpoints may simultaneously be connected to a single DM-NUX-L2-1G endpoint. Creating this virtual hub allows numerous USB devices to control a single host device (such as a PC).¹ The USB signals are transported over the local network and managed through a Crestron control system.

The DM-NUX-L2-1G and DM-NUX-R2-1G are functionally similar. For simplicity within this guide, the term "USB endpoint" is used except where noted. The USB endpoints are also compatible with the USB over Ethernet Extenders with Routing ([DM-NUX-L2](#) and [DM-NUX-R2](#)).



In the Box

- 1 DM-NUX-L2-1G¹ or DM-NUX-R2-1G¹

Additional Items

- 2 Screw, 6-32 x 1/4 in., Pan Head, SEMS (2007218)
- 1 Connector, 2-Pin (2003574)
- 1 Ferrite Bead, Cable Mount (2054945)

1. Refer to the [DM-NUX-L2-1G](#) and [DM-NUX-R2-1G](#) product pages for color variations.

DM NUX USB over Network Wall Plates with Routing



Install the USB Endpoint

The USB endpoint uses Power over Ethernet (PoE) and mounts in a North American, unobstructed, 1-gang electrical box (not included). A minimum mounting depth of 2 in. (51 mm) is required. The DM-NUX-L2-1G also receives power from the USB host port.

The DM-NUX-L2-1G and DM-NUX-R2-1G may be used without a control system or DigitalMedia™ system to offer point-to-point USB extension over a LAN or a dedicated CAT5e (or higher) cable.

NOTE: A ferrite bead is provided to reduce or prevent EMI (electromagnetic interference). When using a power source other than PoE, Crestron recommends installing this ferrite bead on the power supply cable close to the device.

Connect the USB Endpoints

Connect the DM-NUX-L2-1G and DM-NUX-R2-1G.

NOTE: Signal routing is not supported when the DM-NUX-L2-1G and DM-NUX-R2-1G are used to provide point-to-point USB extension or when PoE is not being used. In addition, a separate 24V 0.75A power supply is needed.

1. Feed the CAT5e (or better) shielded twisted-pair (STP) cable through the opening on the top of the electrical box.

NOTES:

- To comply with the European Directive (CE), Crestron recommends using high-quality, solid core CAT5e (or better) shielded twisted pair (STP) cable.
- The CAT5e (or better) cable must have a straight-through conductor configuration with no crossovers and must be terminated with 8-conductor RJ45 connectors at both ends.

2. Using CAT5e (or better) cable, connect the LINK port on each endpoint to an Ethernet network, the LAN port of a DigitalMedia transmitter or receiver, or to the LINK port of another DM NUX endpoint. The maximum cable distance is 330 ft (100 m).

CAUTION: Do not connect the DM-NUX-L2-1G or DM-NUX-R2-1G to a USB-EXT extender. The USB-EXT extenders are intended for use as point-to-point USB extenders and must not be connected to an Ethernet LAN or any other network device via the Link port.

3. Using a USB 2.0 A to B cable (not included), connect the USB B end to the DM-NUX-L2-1G host port (🔌), and connect the USB A end to a USB Type A port on the host device (USB 1.1 or 2.0 compatible).

DM NUX USB over Network Wall Plates with Routing

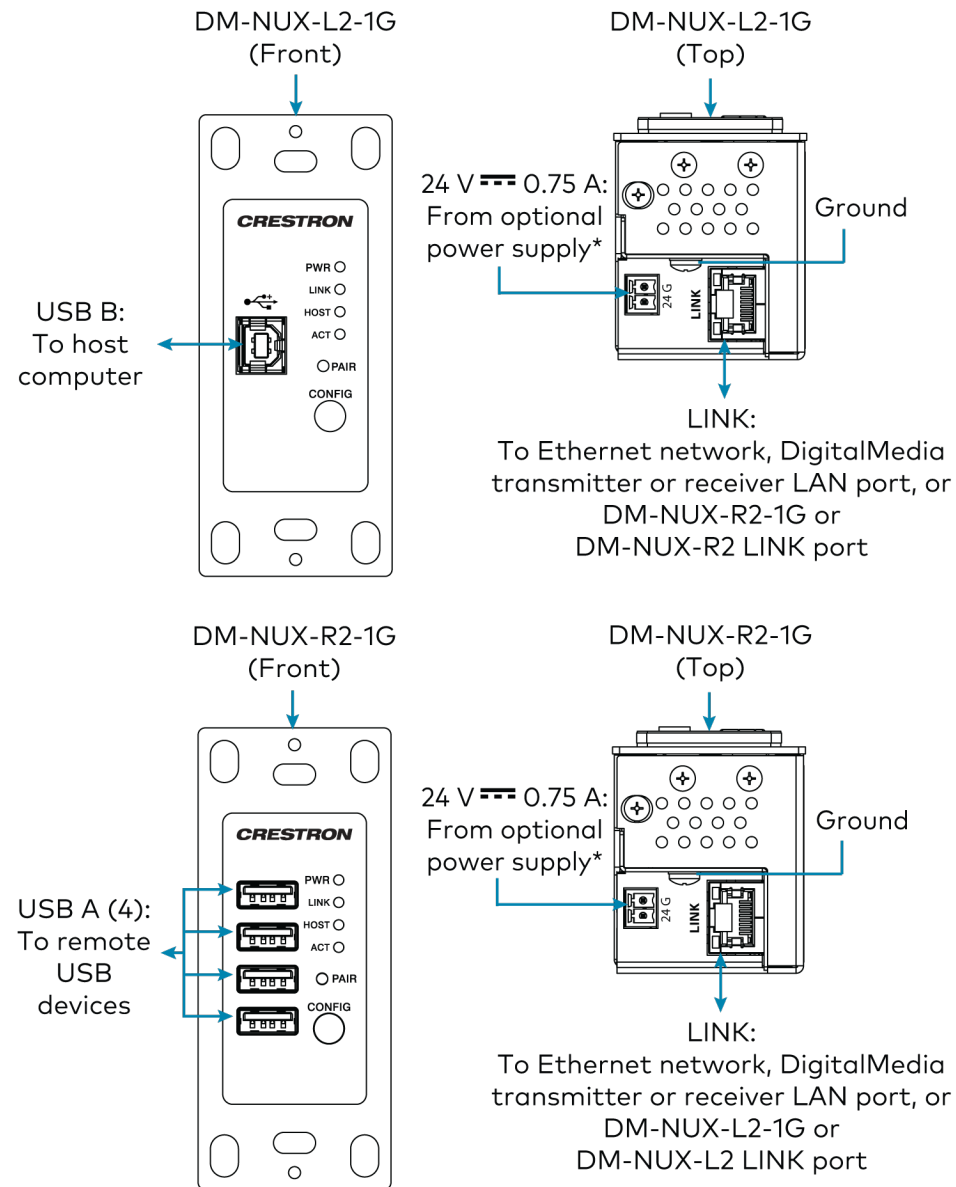

*Connection to a 24VDC power supply is not required when PoE is used to power the USB extender or when the DM-NUX-L2-1G is connected to the Host device.

NOTE: The CONFIG jack on the USB endpoint is reserved for factory use only.

Mount the USB Endpoint

1. Place the USB endpoint into the electrical box.
2. Use two included 6-32 x 1/4 in. pan-head mounting screws to attach the USB endpoint to the electrical box.
3. Attach a faceplate (not included) to the USB endpoint.

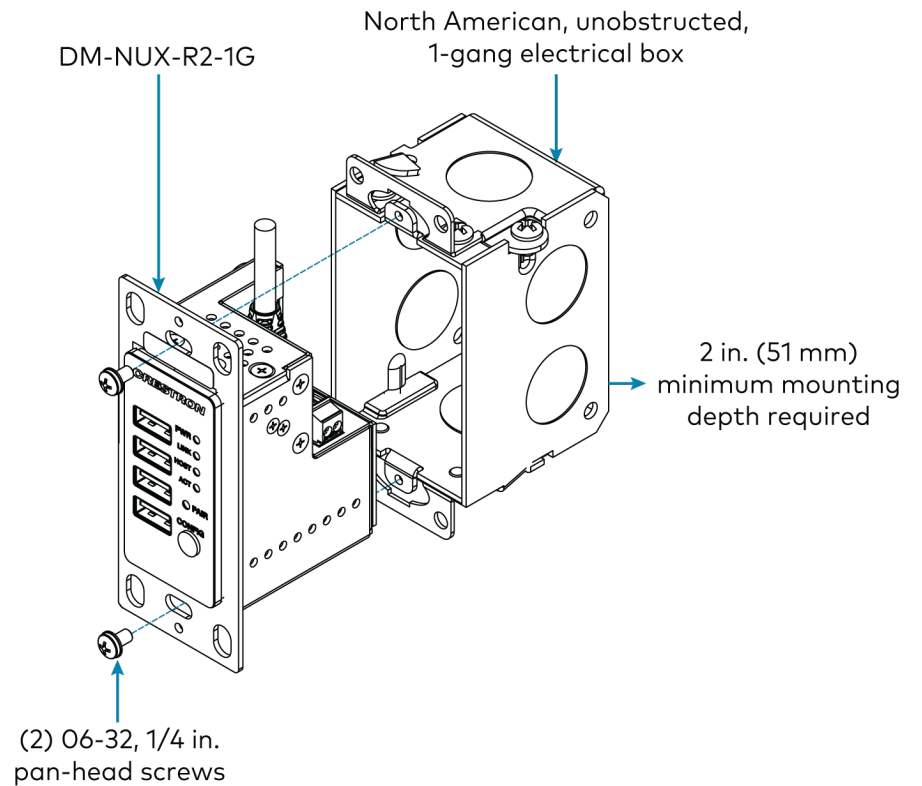

DM NUX USB over Network Wall Plates with Routing

Connect the USB Devices

1. Install any software on the host computer that is required to operate the USB device(s). Refer to the USB device documentation for installation instructions.
2. Using USB 2.0 cables (not supplied), connect the USB devices (USB 1.1 or 2.0 compatible) to the DM-NUX-R2-1G. Up to four USB devices may be connected.
3. Confirm that each USB device is properly installed on the host computer and that it is detected by the operating system.

NOTES:

- The USB endpoint is engineered to deliver maximum compatibility with the widest possible range of devices. Crestron does not guarantee that all USB devices or hosts are compatible with the USB endpoint.
- A web camera may not be used when five or more DM-NUX-R2-1G endpoints are paired.
- Video from two cameras connected to a DM-NUX-R2-1G may not be viewed on different applications simultaneously.
- The USB endpoint supports high-speed (480 Mbps) USB devices; however, DM 8G+® Ethernet links support speeds up to 100 Mbps only. If higher bandwidth is required, ensure that the USB endpoint is communicating via a gigabit Ethernet network.

Check the Installation

Check that the ACT, HOST, LINK, and PWR LEDs light on both the DM-NUX-L2-1G and the DM-NUX-R2-1G. If the HOST or LINK LEDs do not light, then the cabling between the USB endpoints and the network may be installed incorrectly or may be defective.

The following table describes the behavior of the LEDs on the front panel of the USB endpoint.

LED	Color	Description
ACT	Flashing amber	Data transmission is occurring between the DM-NUX-L2-1G and the DM-NUX-R2-1G.
HOST	Solid green	The host device is recognizing the USB endpoint.
LINK	Solid green	A valid link is established between the USB endpoint.
	Fast-flashing green	The USB endpoint is in Pairing mode.
	Slow-flashing green	The USB endpoint is attempting to establish a link.
PWR	Blue	The USB endpoint is receiving power.

Additionally, check to see whether USB endpoint system has been installed correctly on the host computer. Refer to the below instructions.

For Windows Software:

1. Open **Device Manager**.
2. Expand the **Universal Serial Bus** controllers node.
3. Check to see if the extender system appears on the list of controllers. If the extender system has been properly installed, it appears on the list as a "Generic USB Hub."

DM NUX USB over Network Wall Plates with Routing

For macOS Software:

1. Open **System Profiler**.
2. In the left column under Hardware, select **USB**.
3. Check to see if the extender system appears in the USB Device Tree at the top right of the System Profiler window. If the extender system has been properly installed, it is listed as a "Hub" under the **USB High-Speed Bus/USB Bus** node.

If the USB endpoint system does not detect correctly or fails to detect, refer to [Troubleshoot the USB Endpoint](#).



Program the USB Endpoint

Program the USB endpoint using the DM-NUX Module in the Crestron Studio® application or SIMPL Windows.

Pair the USB Endpoint (Optional)

Pairing the USB endpoint establishes a link between the DM-NUX-L2-1G and DM-NUX-R2-1G. Manual pairing may be performed when a DM-NUX-L2-1G and DM-NUX-R2-1G are directly connected to each other in a point-to-point configuration or connected over the Network for multipoint connections. In a point-to-point configuration, USB switching is not performed. In a configuration in which USB switching is to be performed, SIMPL programming automatically pairs the extenders.

Pair a DM-NUX-L2-1G to a DM-NUX-R2-1G.

1. Ensure that the DM-NUX-L2-1G is directly connected to the DM-NUX-R2-1G.

2. On the DM-NUX-L2-1G, press and hold the **PAIR** button for less than 10 seconds. The LINK LED on the front panel of the endpoint starts flashing green fast, indicating that the endpoint is in Pairing mode.

NOTE: Press and hold the **PAIR** button a second time for less than 10 seconds to cancel Pairing mode.

3. Within 10 minutes of activating Pairing mode on the DM-NUX-L2-1G, press and hold the **PAIR** button on the DM-NUX-R2-1G for less than 10 seconds. The LINK LED on the endpoint starts flashing green, indicating that the unit is in Pairing mode.

NOTE: Press and hold the **PAIR** button a second time for less than 10 seconds to cancel Pairing mode.

4. Observe that the LINK LEDs on both endpoints may start flashing slowly before turning solid green. Once the LINK LEDs are solid green, a valid link is established between both endpoints.

NOTE: If more than 10 minutes pass and the endpoints are not yet paired, the endpoints switch back to the regular mode of operation and reestablish the previous links they had (if any).

Unpair a USB Endpoint

If pairing must be removed from an endpoint, press and hold the **PAIR** button for more than 10 seconds.

DM NUX USB over Network Wall Plates with Routing



Troubleshoot the USB Endpoint

The following table provides corrective actions for possible trouble situations. If further assistance is required, please contact a [Crestron Customer service representative](#).

Symptom	Issue	Action
The PWR LED on the DM-NUX-L2-1G is off.	The endpoint is not receiving power from the USB port.	Ensure that the host device is connected to the DM-NUX-R2-1G. If the problem persists, connect the USB cable to another USB port on the host device.
The PWR LED on the DM-NUX-R2-1G is off.	The endpoint is not receiving power from the PoE connection or the optional AC power source.	Check the PoE connection or the optional power source for sufficient supply.
The LINK LED is off.	No connection exists between the DM-NUX-L2-1G and the DM-NUX-R2-1G.	Verify that the CAT5e (or better) cable connections between the extenders.
	The CAT5e (or better) cable is defective.	Replace the cable.
The LINK LED is blinking fast.	No connection exists between the DM-NUX-L2-1G and the DM-NUX-R2-1G.	Verify that the extenders are connected directly or are connected to active network switches.
	Network switches exist on different subnets.	Ensure that network switches can communicate with each other and are on the same subnet.
	Network switch is blocking traffic from the extenders.	Ensure that traffic is not blocked due to MAC address or traffic patterns. If the problem persists, contact the network administrator.
The LINK LED is blinking slowly.	The DM-NUX-L2-1G and DM-NUX-R2-1G are paired with each other but have not yet established a link.	If the LINK LED does not display solid green after a few minutes, contact the network administrator to determine if any traffic is being blocked between the endpoint.
The LINK LED on the DM-NUX-L2-1G is on, but the Host LED is off.	One or more of the following conditions exist: <ul style="list-style-type: none"> The host device is not powered on. The DM-NUX-L2-1G is not connected to the computer. The host device is not recognizing the DM-NUX-L2-1G. The host device does not support USB hubs. 	Disconnect and reconnect the devices and endpoints: <ol style="list-style-type: none"> 1. Disconnect all USB devices from the DM-NUX-R2-1G. 2. Disconnect the DM-NUX-L2-1G from the host device. 3. Disconnect the DM-NUX-R2-1G from the AC power. 4. Reconnect the DM-NUX-L2-1G to the host device. 5. Reconnect the DM-NUX-R2-1G to the AC power.

DM NUX USB over Network Wall Plates with Routing



Visit the Product Page

Scan the QR code to visit the product page.

DM-NUX-L2-1G



www.crestron.com/model/6512570

DM-NUX-R2-1G



www.crestron.com/model/6512572

Additional Information

Original Instructions

The U.S. English version of this document is the original instructions. All other languages are a translation of the original instructions.

Regulatory Models: M201904002

Crestron product development software is licensed to Crestron dealers and Crestron Service Providers (CSPs) under a limited nonexclusive, nontransferable Software Development Tools License Agreement. Crestron product operating system software is licensed to Crestron dealers, CSPs, and end-users under a separate End-User License Agreement. Both of these Agreements can be found on the Crestron website at www.crestron.com/legal/software_license_agreement.

The product warranty can be found at www.crestron.com/warranty.

The specific patents that cover Crestron products are listed at www.crestron.com/legal/patents.

Certain Crestron products contain open source software. For specific information, visit www.crestron.com/opensource.

Crestron, the Crestron logo, DigitalMedia, and DM 8G+ are either trademarks or registered trademarks of Crestron Electronics, Inc. in the United States and/or other countries. macOS is either a trademark or registered trademark of Apple, Inc. in the United States and/or other countries. Windows is either a trademark or registered trademark of Microsoft Corporation in the United States and/or other countries. Other trademarks, registered trademarks, and trade names may be used in this document to refer to either the entities claiming the marks and names or their products. Crestron disclaims any proprietary interest in the marks and names of others. Crestron is not responsible for errors in typography or photography.

©2022 Crestron Electronics, Inc.

Doc. 9207A

01/27/22