

## TSD-2020-PMK

### Pre-Construction Wall Mount Kit for TSD-2020-WMK-BB

#### DO Install the Device

The Crestron® TSD-2020-PMK consists of a single metal plate that fastens to two studs of a framed wall prior to hanging drywall. Standard drywall screws or nails to attach the TSD-2020-PMK are not supplied.

The plate is designed to provide the necessary support for the TSD-2020-WMK-BB Wall Mount Kit and Back Box (sold separately).

To install the device, do the following:

1. Position the plate against the front edges of the studs.

**CAUTION:** Allow an air gap of at least 12 inches (305 mm) in the wall cavity above and below the TSD-2020-PMK for heat dissipation.

2. Attach the plate to the studs using standard drywall screws or nails (not supplied).

Mounting the TSD-2020-PMK

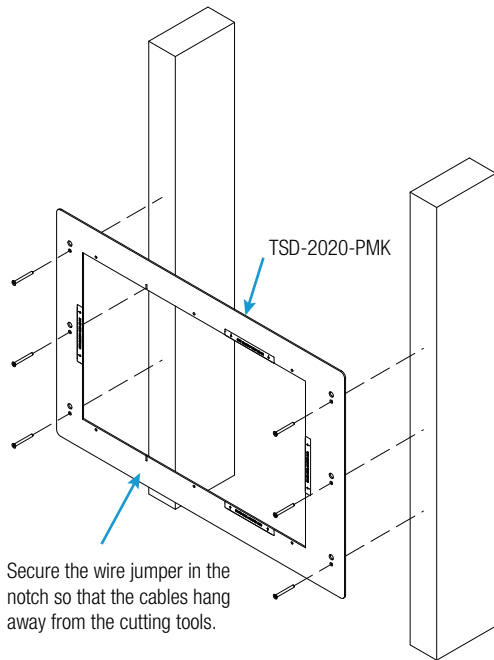

3. Position the drywall over the TSD-2020-PMK.

4. Cut a rectangular opening in the drywall to expose the six 06-32 tapped holes shown in the illustration to the right.

#### DO Check the Box

QTY	PRODUCT	COLOR	PART NUM.
1	Metal Cover Plate, Blank		2041923
6	Screws, 06-32 x 1 1/2"		2007254
1	Wire Jumper	Black	2007838

**NOTE:** Cut the drywall along the inside edge of the mounting plate. The labels on the front of the mounting plate indicate the perimeter of the opening that should be cut.

**NOTE:** The six tapped holes on the front of the mounting plate must be exposed in order to accept the TSD-2020-WMK-BB mounting screws. These holes are found along the top and bottom of the drywall opening.

5. Complete the installation by installing the optional cover plate with the included 06-32 x 1 1/2" screws, installing the TSD-2020-WMK-BB, or leaving the hole open (if permitted by local building codes).

Installing the Cover Plate (Exploded View)

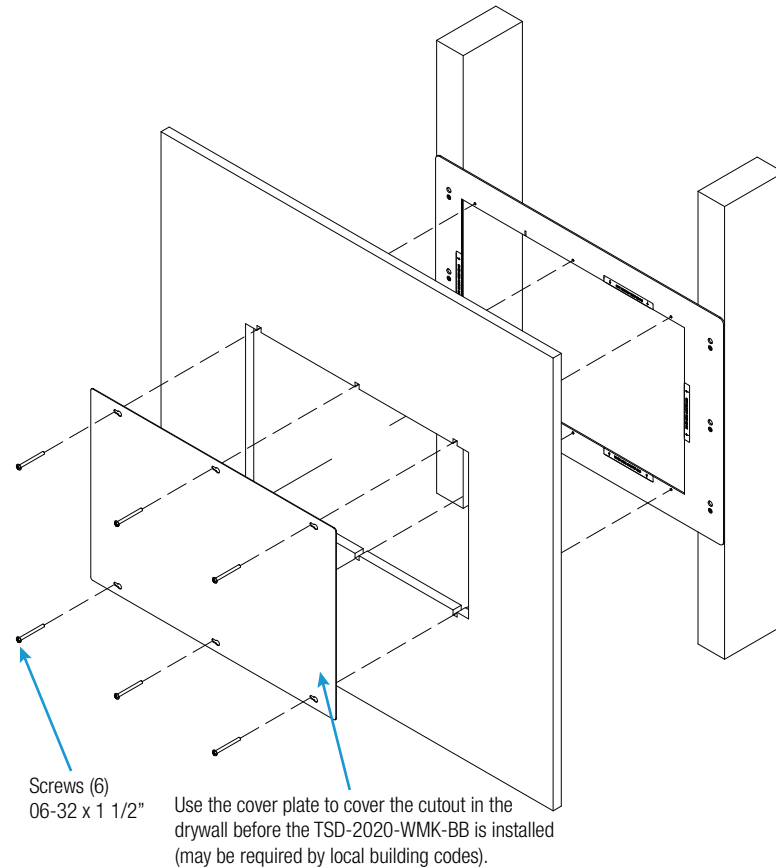

Installing the TSD-2020-WMK-BB (Exploded View)

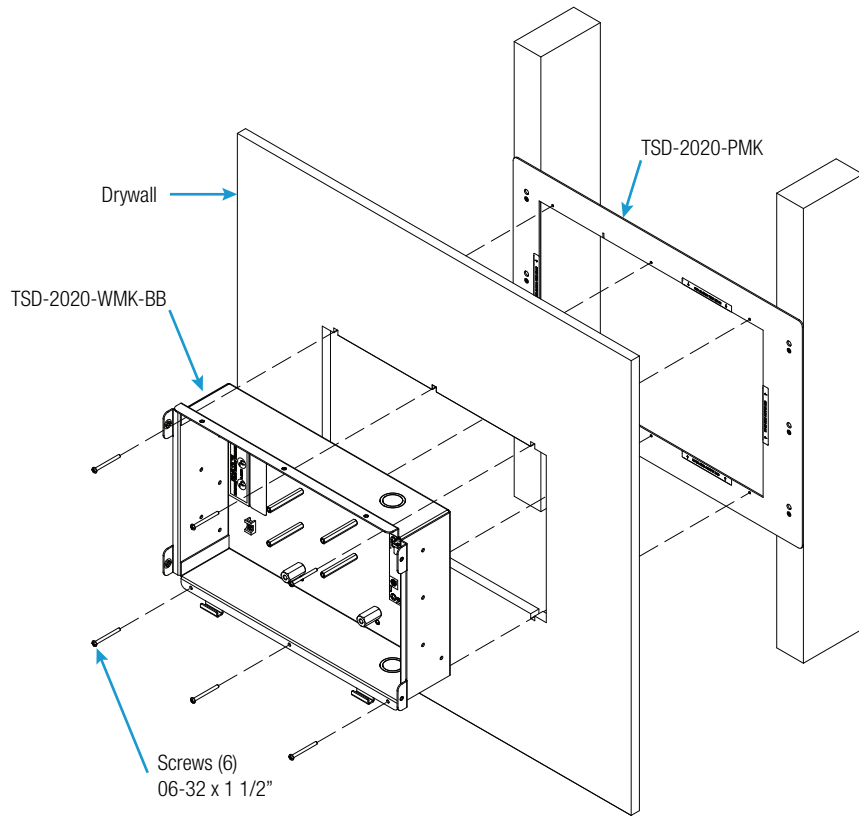

**DO** Learn More

Visit the website for additional information and the latest firmware updates.

**Crestron Electronics**  
15 Volvo Drive, Rockleigh, NJ 07647  
888.CRESTRON | [www.crestron.com](http://www.crestron.com)



The specific patents that cover Crestron products are listed at [patents.crestron.com](http://patents.crestron.com).

The product warranty can be found at [www.crestron.com/warranty](http://www.crestron.com/warranty).

Crestron and the Crestron logo are either trademarks or registered trademarks of Crestron Electronics, Inc. in the United States and/or other countries. Other trademarks, registered trademarks, and trade names may be used in this document to refer to either the entities claiming the marks and names of their products. Crestron disclaims any proprietary interest in the marks and names of others. Crestron is not responsible for errors in typography or photography.

This document was written by the Technical Publications department at Crestron.

©2015 Crestron Electronics, Inc.