

Crestron **PMK-1000L**
Pre-Construction Wall Mount Kit
for APAD

Installation Guide



Contents

Pre-Construction Wall Mount Kit: PMK-1000L	1
Description.....	1
Setup.....	3
Mounting.....	3
Installation.....	4
Other Mounting Option Accessories.....	6
Resources.....	7
Industry Compliance.....	7
Reference Documents.....	7
Further Inquiries.....	7
Future Updates.....	7
Return and Warranty Policies.....	8
Merchandise Returns / Repair Service.....	8
CRESTRON Limited Warranty.....	8

All brand names, product names and trademarks are the property of their respective owners.
©2008 Crestron Electronics, Inc.

Pre-Construction Wall Mount Kit: PMK-1000L

Description

The PMK-1000L is a pre-construction mount kit for the Crestron® APAD LCD controller. The PMK-1000L is used for installation on a stud. For custom controller placement without a stud, use the TMK/WMKT-1000L or MMK/WMKM-1000L. The PMK-1000L includes a 12-inch long, 18 AWG jumper wire to secure controller cabling prior to drywall installation and to avoid damaging the cables when the opening is routed. Refer to the physical views of the PMK-1000L shown on the following page. The table that follows lists all parts included with the PMK-1000L.

NOTE: This mounting kit is to be used only with the APAD LCD controller.

Supplied Hardware for the PMK-1000L

DESCRIPTION	PART NUMBER	QUANTITY
Metal, Plate, Pre-Construction	4505161	1
Metal, Plate, Cover	2004826	1
Screw, #04-40 x 2", Pan, Phil	2018793	4
Jumper wire, 12", 18 AWG, Black	2007838	1

The dimensions of the PMK-1000L are shown below.

Dimensional Drawing

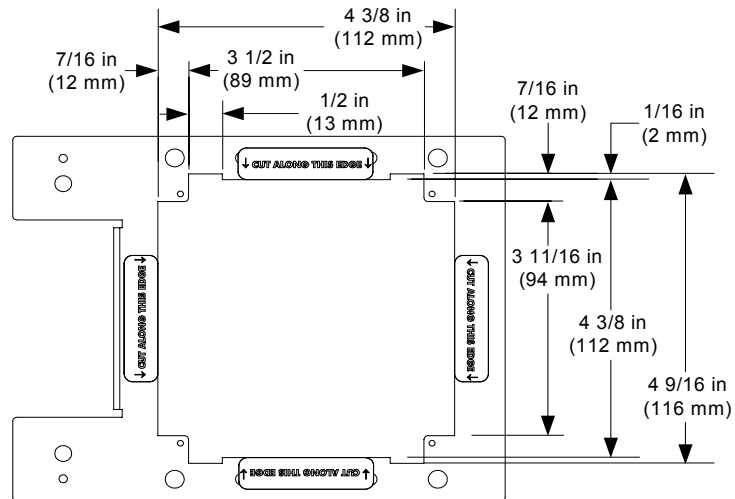
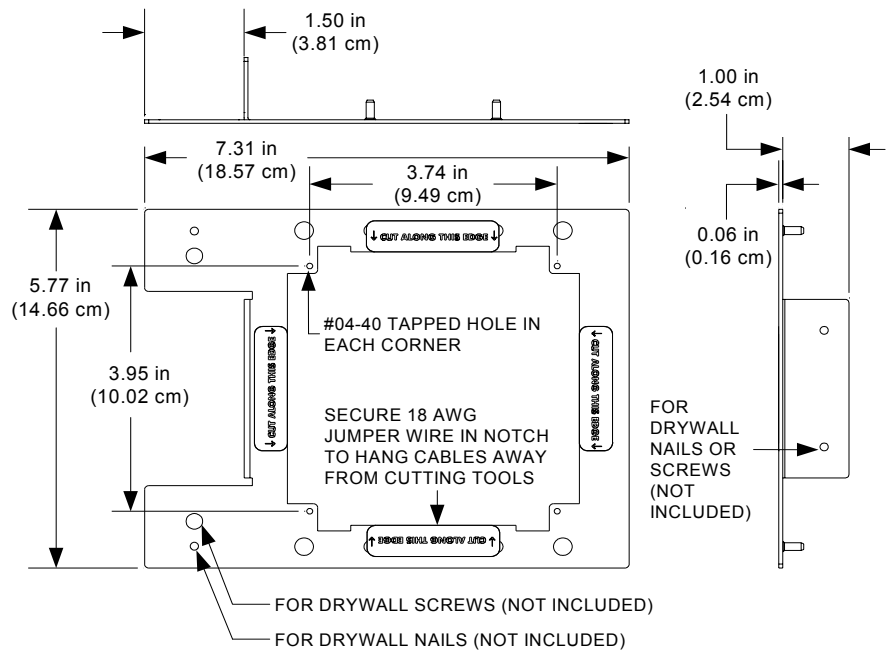

Dimensional Drawing - Cover Plate

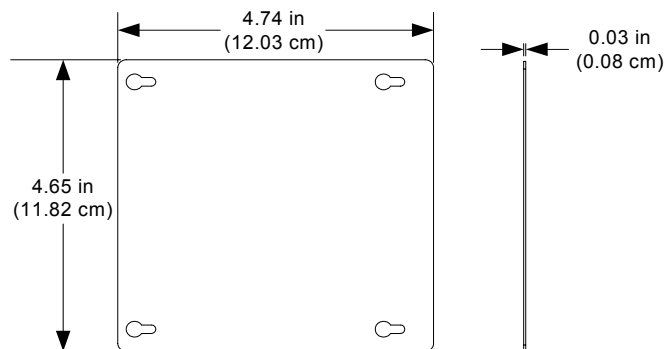

Setup

Mounting

The PMK-1000L consists of a single metal plate, which fastens to the stud of a framed wall prior to hanging drywall. Standard drywall nails or screws to attach the PMK-1000L are not supplied (length can vary).

The plate is designed to provide the necessary support for a single controller and can mount to the right or left side of a stud. Confirm that the PMK-1000L is level before applying drywall.

Mounting the PMK-1000L

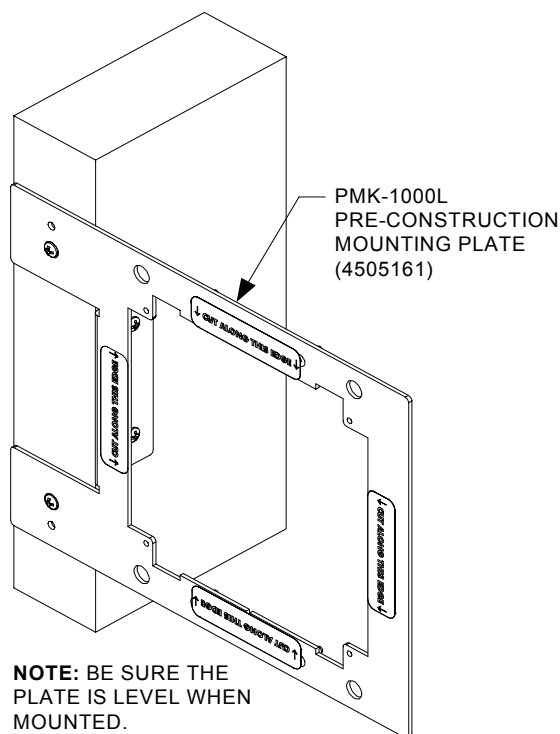

CAUTION: Allow an air gap of at least 12 inches (30.48 cm) in the wall cavity above and below the controller for heat dissipation.

After drywall is positioned, a rectangular opening must be made. Position the opening to expose the #40-40 tapped holes in each corner.

NOTE: Cut the drywall along the inside edge of the front of the mounting plate. The labels on the front of the mounting plate indicate the perimeter of the opening that should be cutout. Refer to the **NOTE** in “Mounting the PMK-1000L” shown on the illustration above.

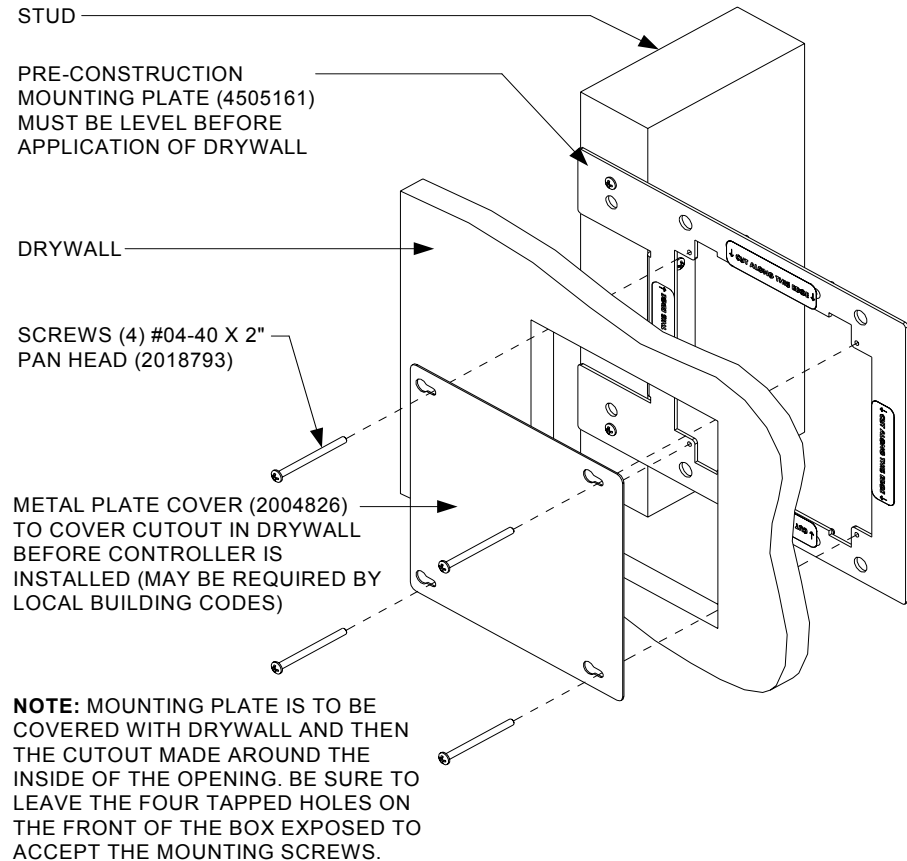
Mounted View with Cover Plate (Mounting Example Prior to Drywall Installation)

NOTE: The four tapped holes on the front of the mounting plate must be exposed to accept the controller mounting screws. These holes are found beneath the drywall just outside the four corners of the opening made by cutting out the drywall. Refer to the **NOTE** in “Mounted View with Cover Plate” illustration above.

Installation

Complete the installation by either installing the controller, leaving the hole open (if permitted by local building codes) or installing the optional cover plate with the included #04-40 x 2” screws. If the controller is to be installed, refer to the latest revision of the APAD Installation and Operations Guide (Doc. 6455) for installation instructions. The document is available from the Crestron website (<http://www.crestron.com/manuals>). Refer also to the comprehensive illustration on the following page.

Controller Mounting – Exploded View

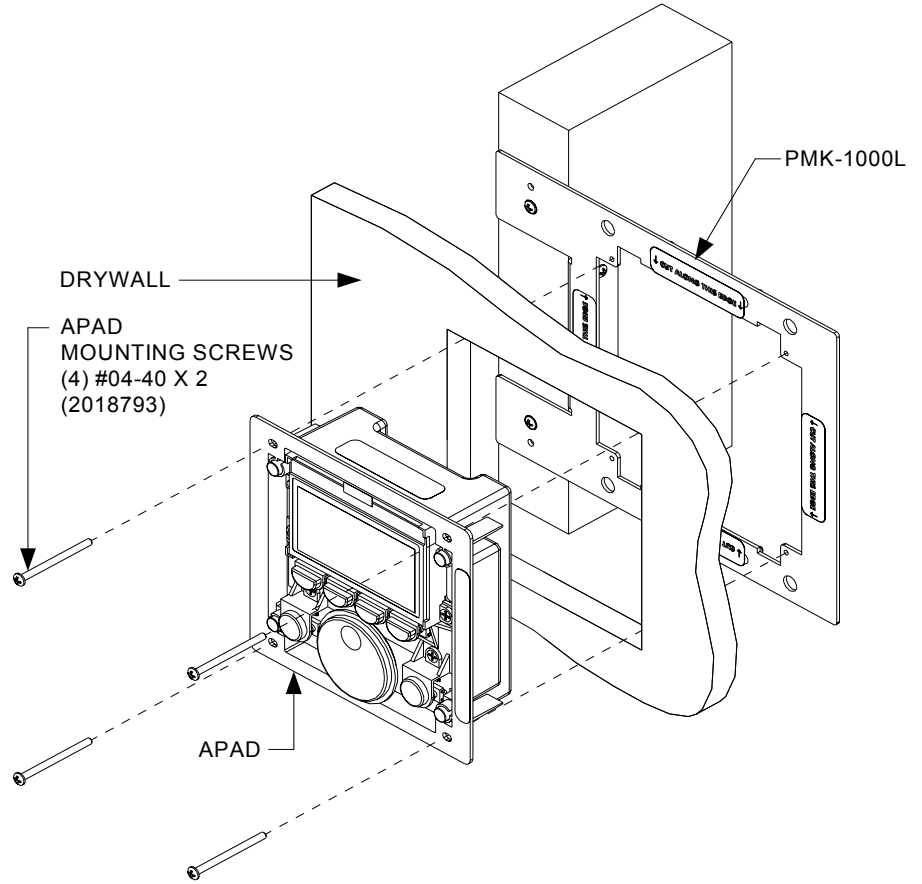

Other Mounting Option Accessories

If too much of the mounting plate is exposed after the drywall is cut, you may need to patch the area. Crestron provides the following accessories:

- MMK-1000L (Doc. 6062) - for larger repairs and to fill in larger irregularities around the opening (requires plastering).
- TMK-1000L (Doc. 6063) - for smaller repairs and to provide a smooth edge at the opening. This option provides a finished appearance and is preferred when wallpaper is hung.

The manuals for the MMK-1000L and TMK-1000L are available from the Crestron website.

Resources

Industry Compliance

As of the date of manufacture, the PMK-1000L has been tested and found to comply with specifications for CE marking marking.



Reference Documents

The latest version of all documents mentioned within the guide can be obtained from the Crestron website (<http://www.crestron.com/manuals>). This link will provide a list of product manuals arranged in alphabetical order by model number.

List of Related Reference Documents

DOCUMENT TITLE
APAD Wall Mount LCD Controller
MMK-1000L Mud Mount Kit
TMK-1000L Trim Ring Mount Kit

Further Inquiries

If you cannot locate specific information or have questions after reviewing this guide, please take advantage of Crestron's award winning customer service team by calling the Crestron corporate headquarters at 1-888-CRESTRON [1-888-273-7876]. For assistance in your local time zone, refer to the Crestron website (www.crestron.com/offices) for a listing of Crestron worldwide offices.

You can also log onto the online help section of the Crestron website (www.crestron.com/onlinehelp) to ask questions about Crestron products. First-time users will need to establish a user account to fully benefit from all available features.

Future Updates

As Crestron adds improvements to the PMK-1000L additional information may be made available as manual updates. These updates are solely electronic and serve as intermediary supplements prior to the release of a complete technical documentation revision.

Check the Crestron website periodically for manual update availability and its relevance. Updates are identified as an “Addendum” in the Download column.

Return and Warranty Policies

Merchandise Returns / Repair Service

1. No merchandise may be returned for credit, exchange or service without prior authorization from CRESTRON. To obtain warranty service for CRESTRON products, contact an authorized CRESTRON dealer. Only authorized CRESTRON dealers may contact the factory and request an RMA (Return Merchandise Authorization) number. Enclose a note specifying the nature of the problem, name and phone number of contact person, RMA number and return address.
2. Products may be returned for credit, exchange or service with a CRESTRON Return Merchandise Authorization (RMA) number. Authorized returns must be shipped freight prepaid to CRESTRON, 6 Volvo Drive, Rockleigh, N.J. or its authorized subsidiaries, with RMA number clearly marked on the outside of all cartons. Shipments arriving freight collect or without an RMA number shall be subject to refusal. CRESTRON reserves the right in its sole and absolute discretion to charge a 15% restocking fee plus shipping costs on any products returned with an RMA.
3. Return freight charges following repair of items under warranty shall be paid by CRESTRON, shipping by standard ground carrier. In the event repairs are found to be non-warranty, return freight costs shall be paid by the purchaser.

CRESTRON Limited Warranty

CRESTRON ELECTRONICS, Inc. warrants its products to be free from manufacturing defects in materials and workmanship under normal use for a period of three (3) years from the date of purchase from CRESTRON, with the following exceptions: disk drives and any other moving or rotating mechanical parts, pan/tilt heads and power supplies are covered for a period of one (1) year; touchscreen display and overlay components are covered for 90 days; batteries and incandescent lamps are not covered.

This warranty extends to products purchased directly from CRESTRON or an authorized CRESTRON dealer. Purchasers should inquire of the dealer regarding the nature and extent of the dealer's warranty, if any.

CRESTRON shall not be liable to honor the terms of this warranty if the product has been used in any application other than that for which it was intended or if it has been subjected to misuse, accidental damage, modification or improper installation procedures. Furthermore, this warranty does not cover any product that has had the serial number altered, defaced or removed.

This warranty shall be the sole and exclusive remedy to the original purchaser. In no event shall CRESTRON be liable for incidental or consequential damages of any kind (property or economic damages inclusive) arising from the sale or use of this equipment. CRESTRON is not liable for any claim made by a third party or made by the purchaser for a third party.

CRESTRON shall, at its option, repair or replace any product found defective, without charge for parts or labor. Repaired or replaced equipment and parts supplied under this warranty shall be covered only by the unexpired portion of the warranty.

Except as expressly set forth in this warranty, CRESTRON makes no other warranties, expressed or implied, nor authorizes any other party to offer any warranty, including any implied warranties of merchantability or fitness for a particular purpose. Any implied warranties that may be imposed by law are limited to the terms of this limited warranty. This warranty statement supersedes all previous warranties.

Trademark Information

All brand names, product names and trademarks are the sole property of their respective owners. Windows is a registered trademark of Microsoft Corporation. Windows95/98/Me/XP/Vista and WindowsNT/2000 are trademarks of Microsoft Corporation.

This page is intentionally left blank.



Crestron Electronics, Inc.
15 Volvo Drive Rockleigh, NJ 07647
Tel: 888.CRESTRON
Fax: 201.767.7576
www.crestron.com

Installation Guide – DOC. 6061A
(2002105)
01.08
Specifications subject to
change without notice.