

Crestron **BB-4L**
Wall Mount Back Box

Installation Guide



Contents

Wall Mount Back Box: BB-4L	1
Description.....	1
Setup.....	4
Assembly.....	4
Mounting.....	4
Installation.....	6
Other Mounting Option Accessories.....	7
Resources.....	8
Industry Compliance.....	8
Reference Documents.....	8
Further Inquiries.....	8
Future Updates.....	8
Return and Warranty Policies.....	9
Merchandise Returns / Repair Service.....	9
CRESTRON Limited Warranty.....	9

All brand names, product names and trademarks are the property of their respective owners.
©2007 Crestron Electronics, Inc.

Wall Mount Back Box: BB-4L

Description

The BB-4L is a UL[®]-listed pre-construction mounting option for the Crestron Isys[®] TPS-4L wall mounted touchpanel. It is designed to be installed before the drywall is put up. The table below lists all parts included with the BB-4L.

NOTE: If mounting into a material other than drywall (for example, wood lectern, concrete, or rock) use the cutout template, available in the post-construction kit WMKM-4L or WMKT-4L.

NOTE: For concrete and rock mounting material, allow for proper ventilation before mounting the touchpanel.

Supplied Hardware for the BB-4L

DESCRIPTION	PART NUMBER	QUANTITY
Assembly, Wall Mount, Back Box	4505359	1
Metal, Plate, Blank	2013239	1
Screw, #08-8B x 1/4", Pan, Phil	2007277	1
Screw, #04-40 x 2", Pan, Phil	2018793	4

The mounted view of the BB-4L is shown in the following illustration.

BB-4L Mounted View (Optional Cover Plate Attached)

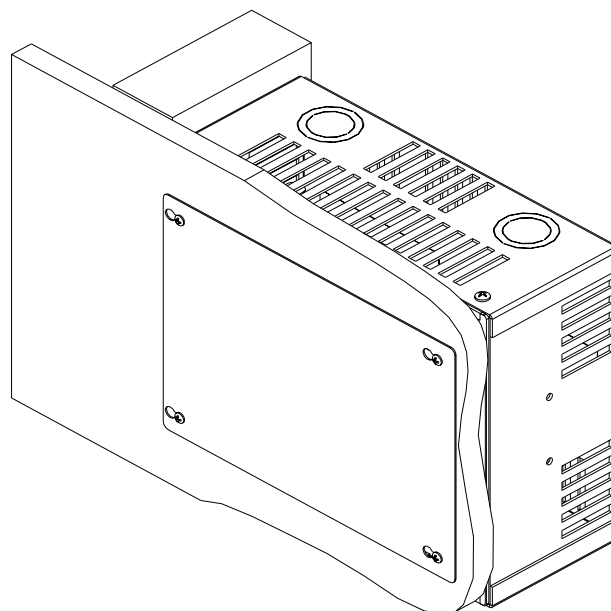

The dimensions of the BB-4L are shown below and on the next page.

Dimensional Drawing (Fully Assembled without Cover Plate)

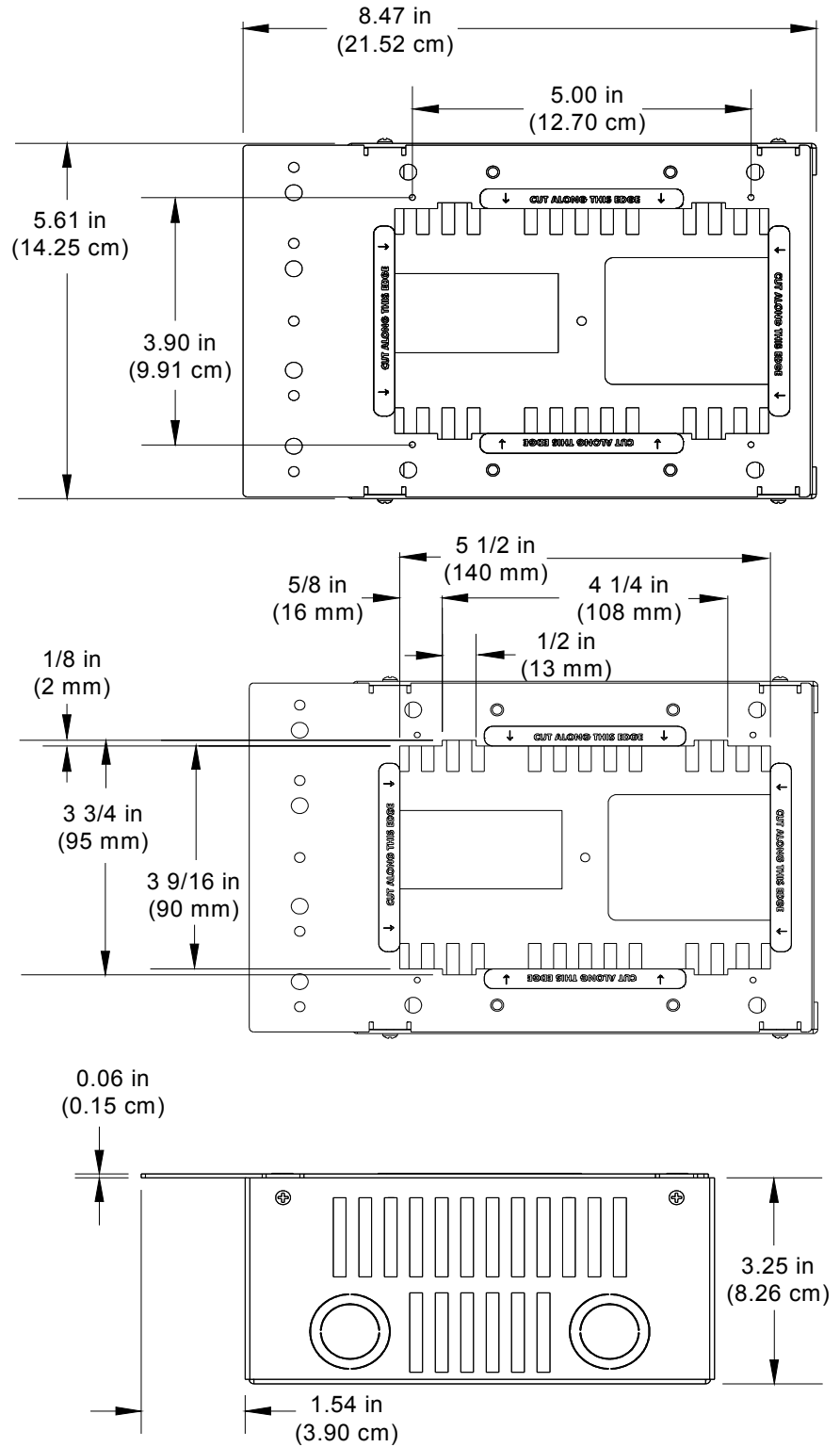

NOTE: Knockout holes are intended for Class 2 wiring only and are 1/2" and 3/4" diameter.

Dimensional Drawing - Cover Plate

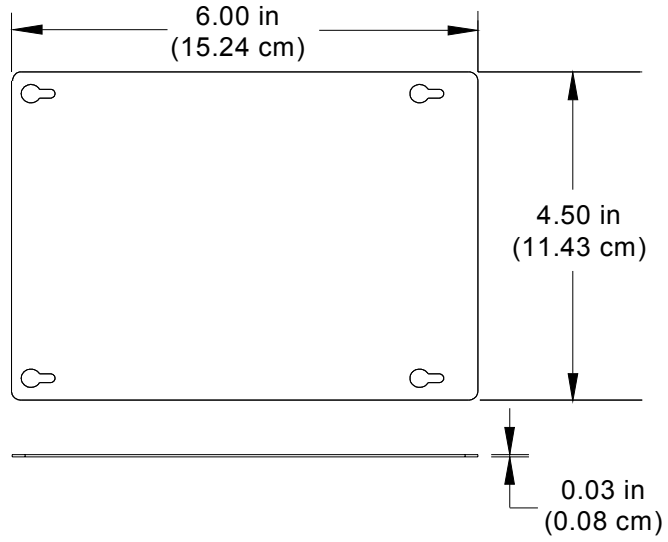

Setup

Assembly

Required Tools:

- #2 Phillips tip screwdriver

The back box mounting enclosure assembly comes fully assembled except for a grounding screw. Complete the following procedure in the order provided.

1. Remove knockouts as required.
2. Attach the supplied #08-8B self-tapping screw to back box mounting enclosure assembly for grounding.

NOTE: #08-8B self-tapping screw (2007277), supplied for grounding purposes, is installed in the rear of the back box mounting enclosure assembly.

Mounting

Required Tools and Materials:

- #2 Phillips tip screwdriver or hammer
- Level
- Standard drywall screws or nails (not included)

CAUTION: Allow an air gap of at least 12 inches (30.48 cm) in the wall cavity above and below the touchpanel for heat dissipation.

NOTE: If your installation is not on wooden studs, be sure to consider the needs of your particular situation. For example, screw type may vary for steel studs, etc.

Complete the following procedure (refer to illustrations on the next page) to mount the back box.

1. Position the back box against the stud so that the extended edge of the attached mounting plate covers the front edge of the stud. Be sure that the side of the back box is also against the side of the stud.
2. Use the level and verify that the back box is horizontal. Leveling must be done before proceeding.
3. Attach the back box to the left or right side of the stud with standard drywall screws or nails (not included). If mounting to the left side of a stud, the back box must be turned over so that the extended edge of the attached mounting plate is on the right side.
4. Feed cables through knockout holes.

NOTE: This assembly should use Class 2 wiring only.

Mounting the Back Box

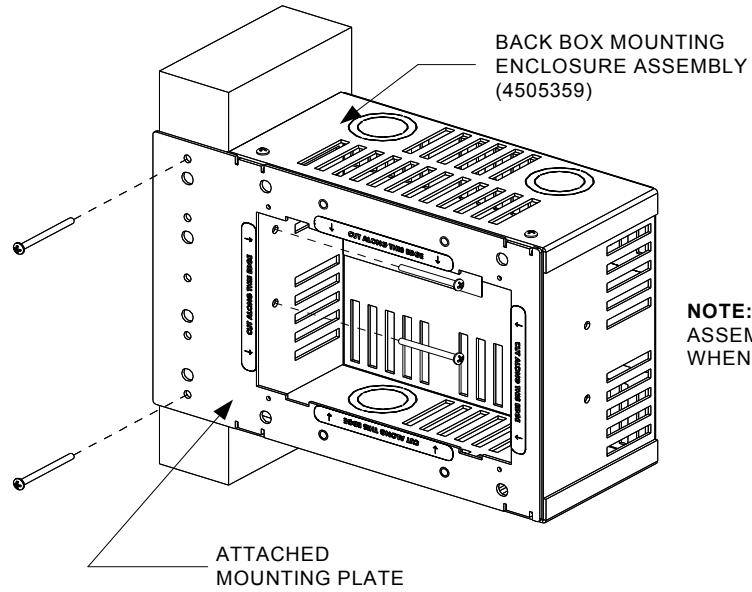

NOTE: BE SURE THE ASSEMBLY IS LEVEL WHEN MOUNTED

Mounted View with Cover Plate (Mounting Example Prior to Drywall Installation)

NOTE: BACK BOX IS TO BE COVERED WITH DRYWALL AND THEN THE CUTOUT MADE AROUND THE INSIDE OF THE OPENING. BE SURE TO LEAVE THE FOUR TAPPED HOLES ON THE FRONT OF THE BOX EXPOSED TO ACCEPT THE MOUNTING SCREWS

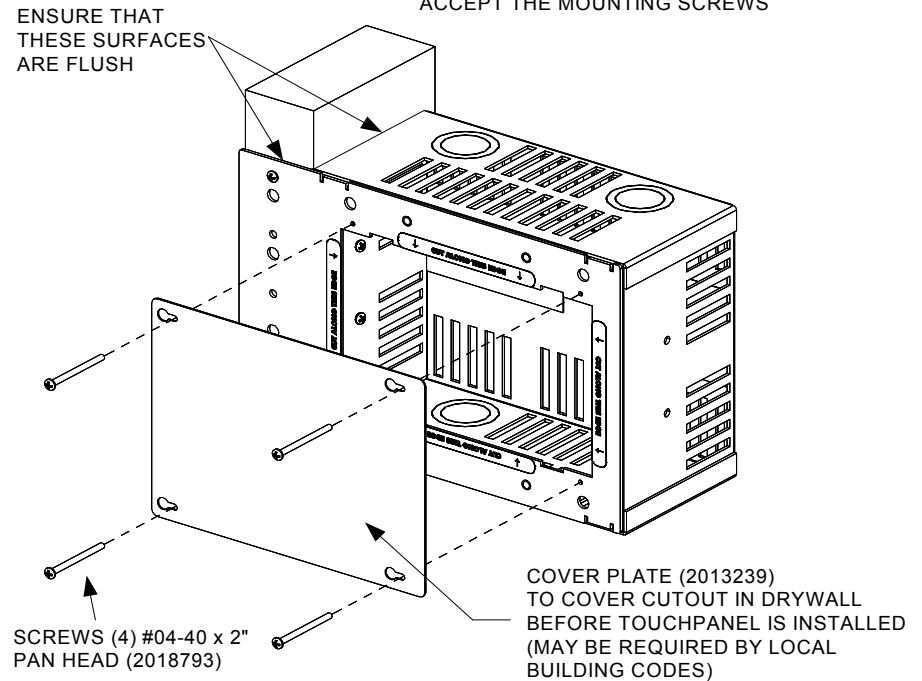

NOTE: Cut the drywall along the inside edge of the front of the back box. The labels on the front of the back box indicate the perimeter of the opening that should be cutout. Refer to the **NOTE** in “Mounting the Back Box” shown on the previous page.

NOTE: The four tapped holes on the front of the back box must be exposed to accept the touchpanel mounting screws. These holes are found beneath the drywall just outside the four corners of the opening made by cutting out the drywall. Refer to the **NOTE** in “Mounted View with Cover Plate” shown on previous page.

Installation

Complete the installation by either installing the touchpanel, leaving the hole open (if permitted by local building codes) or installing the optional cover plate with the included #04-40 x 2” screws. If the touchpanel is to be installed, refer to the latest revision of the TPS-4L Installation and Operations Guide (Doc. 6449) for installation instructions. The document is available from the Crestron website (<http://www.crestron.com/manuals>). Refer also to the following comprehensive illustration.

Touchpanel Mounting – Exploded View

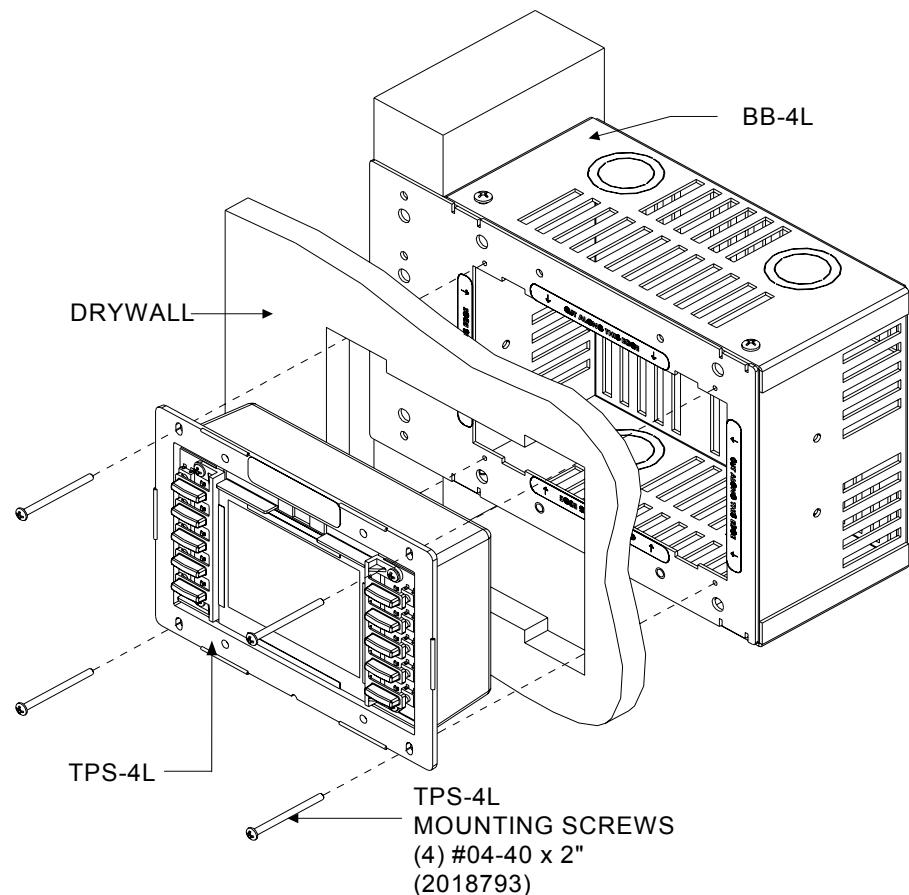

Other Mounting Option Accessories

If too much of the mounting plate is exposed after the drywall is cut, you may need to patch the area. Crestron provides the following accessories:

- MMK-4L (Doc. 6389) - for larger repairs and to fill in larger irregularities around the opening (requires plastering).
- TMK-4L (Doc. 6390) - for smaller repairs and to provide a smooth edge at the opening. This option provides a finished appearance and is preferred when wallpaper is hung.

The manuals for the MMK-4L and TMK-4L are available from the Crestron website.

Resources

Industry Compliance

This product is Listed to applicable UL Standards and requirements by Underwriters Laboratories Inc.



As of the date of manufacture, the BB-4L has been tested and found to comply with specifications for CE marking and standards per EMC and Radiocommunications Compliance Labelling.



Reference Documents

The latest version of all documents mentioned within the guide can be obtained from the Crestron website (<http://www.crestron.com/manuals>). This link will provide a list of product manuals arranged in alphabetical order by model number.

List of Related Reference Documents

DOCUMENT TITLE
MMK-4L and WMKM-4L Mud Mount Kits
TMK-4L and WMKT-4L Trim Ring Mount Kits
TPS-4L Isys® 3.6" Wall Mount Touchpanel

Further Inquiries

If you cannot locate specific information or have questions after reviewing this guide, please take advantage of Crestron's award winning customer service team by calling the Crestron corporate headquarters at 1-888-CRESTRON [1-888-273-7876]. For assistance in your local time zone, refer to the Crestron website (www.crestron.com/offices) for a listing of Crestron worldwide offices.

You can also log onto the online help section of the Crestron website (www.crestron.com/onlinehelp) to ask questions about Crestron products. First-time users will need to establish a user account to fully benefit from all available features.

Future Updates

As Crestron adds improvements to the BB-4L additional information may be made available as manual updates. These updates are solely electronic and serve as intermediary supplements prior to the release of a complete technical documentation revision.

Check the Crestron website periodically for manual update availability and its relevance. Updates are identified as an “Addendum” in the Download column.

Return and Warranty Policies

Merchandise Returns / Repair Service

1. No merchandise may be returned for credit, exchange or service without prior authorization from CRESTRON. To obtain warranty service for CRESTRON products, contact an authorized CRESTRON dealer. Only authorized CRESTRON dealers may contact the factory and request an RMA (Return Merchandise Authorization) number. Enclose a note specifying the nature of the problem, name and phone number of contact person, RMA number and return address.
2. Products may be returned for credit, exchange or service with a CRESTRON Return Merchandise Authorization (RMA) number. Authorized returns must be shipped freight prepaid to CRESTRON, 6 Volvo Drive, Rockleigh, N.J. or its authorized subsidiaries, with RMA number clearly marked on the outside of all cartons. Shipments arriving freight collect or without an RMA number shall be subject to refusal. CRESTRON reserves the right in its sole and absolute discretion to charge a 15% restocking fee plus shipping costs on any products returned with an RMA.
3. Return freight charges following repair of items under warranty shall be paid by CRESTRON, shipping by standard ground carrier. In the event repairs are found to be non-warranty, return freight costs shall be paid by the purchaser.

CRESTRON Limited Warranty

CRESTRON ELECTRONICS, Inc. warrants its products to be free from manufacturing defects in materials and workmanship under normal use for a period of three (3) years from the date of purchase from CRESTRON, with the following exceptions: disk drives and any other moving or rotating mechanical parts, pan/tilt heads and power supplies are covered for a period of one (1) year; touchscreen display and overlay components are covered for 90 days; batteries and incandescent lamps are not covered.

This warranty extends to products purchased directly from CRESTRON or an authorized CRESTRON dealer. Purchasers should inquire of the dealer regarding the nature and extent of the dealer's warranty, if any.

CRESTRON shall not be liable to honor the terms of this warranty if the product has been used in any application other than that for which it was intended or if it has been subjected to misuse, accidental damage, modification or improper installation procedures. Furthermore, this warranty does not cover any product that has had the serial number altered, defaced or removed.

This warranty shall be the sole and exclusive remedy to the original purchaser. In no event shall CRESTRON be liable for incidental or consequential damages of any kind (property or economic damages inclusive) arising from the sale or use of this equipment. CRESTRON is not liable for any claim made by a third party or made by the purchaser for a third party.

CRESTRON shall, at its option, repair or replace any product found defective, without charge for parts or labor. Repaired or replaced equipment and parts supplied under this warranty shall be covered only by the unexpired portion of the warranty.

Except as expressly set forth in this warranty, CRESTRON makes no other warranties, expressed or implied, nor authorizes any other party to offer any warranty, including any implied warranties of merchantability or fitness for a particular purpose. Any implied warranties that may be imposed by law are limited to the terms of this limited warranty. This warranty statement supersedes all previous warranties.

Trademark Information

All brand names, product names and trademarks are the sole property of their respective owners. Windows is a registered trademark of Microsoft Corporation. Windows95/98/Me/XP/Vista and WindowsNT/2000 are trademarks of Microsoft Corporation.



Crestron Electronics, Inc.
15 Volvo Drive Rockleigh, NJ 07647
Tel: 888.CRESTRON
Fax: 201.767.7576
www.crestron.com

Installation Guide – DOC. 6387B
(2019474)
11.07
Specifications subject to
change without notice.