

CCS-UCA-SMK

Swivel Mount Kit for Crestron Mercury™ Tabletop Conference System

DO Prepare the Mounting Location

NOTE: The mounting surface should have a thickness of 1" (25 mm) to 1-3/8" (34 mm).

The kit includes a template that is used to mark the location of the mounting hole on top of the mounting surface, and the location of the stop plate under the mounting surface. When using the template, make sure the arrow on the template points toward the front edge of the mounting surface.

1. Secure the template to a mounting location that allows the full pivot of the device on the top of the mounting surface and a close mounting location for accessories beneath the mounting surface.
2. Place 2" painters tape (not included) on the hole location and mark the hole on the tape.
3. Drill a 1-3/16" (30 mm) mounting hole in the marked location on the tape.
4. Relocate the template to the underside of the mounting surface and orient it so that the arrow on the template points toward the front edge of the table. Verify that the template location of the stop plate permits the Crestron Mercury™ device to swivel.

DO Install the Cable Retention Bracket

NOTE: If a cable retention plate is already installed, it must be removed. For new installations, skip to step 3. Otherwise, follow this procedure:

1. Use two small flat head screwdrivers to slowly pry off the existing retention plate.
2. Remove all adhesive residue from the surface.
3. Clean the surface with an alcohol wipe (not supplied).
4. Remove the paper liner from the back of the cable retention bracket.
5. Install the cable retention bracket as shown in the following diagram.

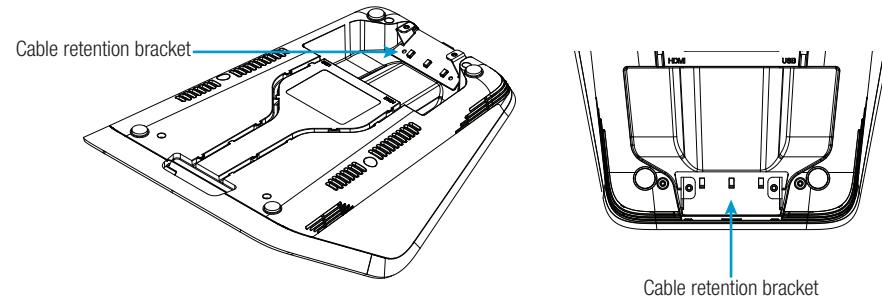

6. Press firmly on the cable retention bracket for approximately 30 seconds.

CAUTION: When turning over the device, place the device on a soft surface to avoid damage to the unit.

DO Connect the Device

1. Drill pilot holes with a 1/8" bit in the stop plate's mounting location and attach the stop plate to the underside of the mounting surface with the six included 8-8B x 1/2" screws.
2. Place the swivel tube plate on the mounting surface.
3. Route all cables that connect to the Crestron Mercury device from underneath the mounting surface through the swivel kit hardware as shown below. Cables with larger connectors should be routed first, followed by cables with smaller connectors.

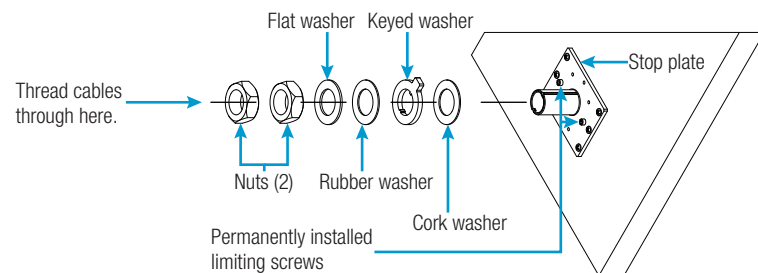

If the HDMI® input cable and the USB cable are to be routed to the front of the Crestron Mercury device, do not route these cables through the swivel kit hardware.

DO Check the Box

QUANTITY	PRODUCT	COLOR	PART NUMBER
1	Bit, Slotted 1/4" W		2049730
1	Bit, Slotted 23/64" W		2049474
1	Bracket, Cable Retention		4526653
1	Cable, HDMI, Male to Female Extender		2049637
4	Insert, Metal, M7, 6-32 Thread, 0.28" L		2049476
2	Insert, Metal, M10, 10-32 Thread, 0.41" L		2049328
2	Nut, 1-1/8"-12		2049390
2	Screw, 4-40 x 1/4", Pan Head, Phillips	Black	2007158
2	Screw, 6-32 x 1/2", Pan Head, Phillips	Black	2007238
2	Screw, 6-32 x 1", Truss Head, Phillips	Black	2049649
6	Screw, 8-8B x 1/2", Pan Head, Phillips		2017784
2	Screw, 8-32 x 1/8", Cap Head, Socket	Black	2017634
2	Screw, 10-32 x 1", Pan Head, Phillips	Black	2049391
1	Stop Plate, Swivel, with Screws		4526651
1	Template, Cutout		4526654
5	Tie Wrap		2047935
1	Washer, Cork, 2.0" OD, 1.19" ID, 0.06" TH		2049448
1	Washer, Keyed		4526609
1	Washer, Metal, 2.0" OD, 1.19" ID, 0.10" TH		2049389
1	Washer, Rubber, 2.0" OD, 1.19" ID, 0.06" TH		2049449

If the Crestron Mercury device's HDMI OUT port is to be used, perform the following procedure:

- a. Connect the HDMI Extension Cable (2049637) to the HDMI OUT port.
- b. Route the cable extender through the swivel tube.
- c. Connect the HDMI cable provided with the Crestron Mercury device to the cable extender.

4. Make the necessary connections to the device. Refer to the DO Guide or Installation Guide included with the Crestron Mercury system.

5. Use the included tie wraps to secure all of the cables to the cable retention bracket that was installed in "DO Install the Cable Retention Bracket."

Standard Wiring



Zoom Wiring



6. If the front USB and HDMI input connections are to be used, press the USB and HDMI IN cables into the channels on the underside of the device as shown in the following diagram (cables removed for clarity) so that the connectors can be routed to the front of the device.

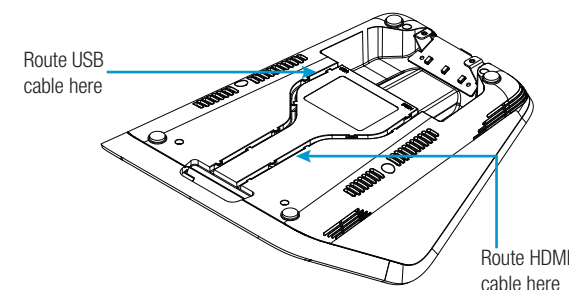

DO Attach the Swivel Tube Plate to the Device

NOTE: A manual bit screwdriver (not included) is required for this procedure.

1. Install the inserts as shown in the following diagram (cables removed for clarity).

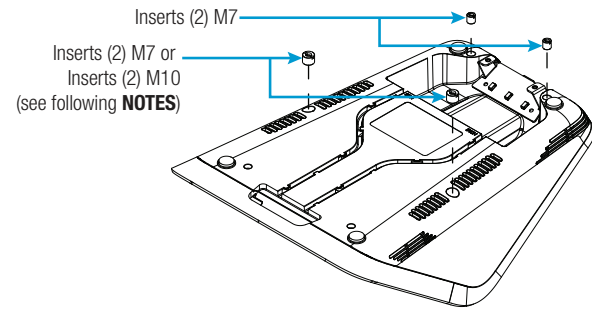

NOTE: Due to variances in manufacturing, these insert locations use either the small diameter inserts or the large diameter inserts. Use the inserts (and matching screws) that fit into the holes in the device's chassis.

NOTE: The M7 inserts drop down into the two center holes in the base prior to tightening.

- a. Place the correct insert in the proper location with the slotted end on top.
- b. Use a manual bit screwdriver to secure the inserts to the Crestron Mercury device by turning each insert until it locks itself snugly into the base.
 - For the smaller insert, use the included 1/4" slotted bit to turn the insert.
 - For the larger insert, use the included 23/64" slotted bit to turn the insert.

2. Refer to the following diagram (cables removed for clarity) to attach the swivel tube plate to the device.

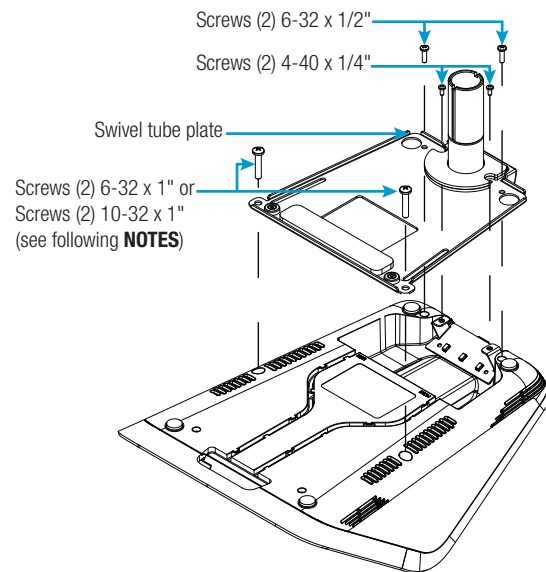

CAUTION: Ensure that all screws are fully seated to avoid damage to the mounting surface.

NOTE: Use the screws that fit the inserts installed in step 1.

NOTE: To avoid bending the swivel tube plate, do not overtorque the screws.

DO Secure the Device to the Mounting Surface

1. Slide the included hardware onto the swivel tube as shown in the following diagram (cables removed for clarity).

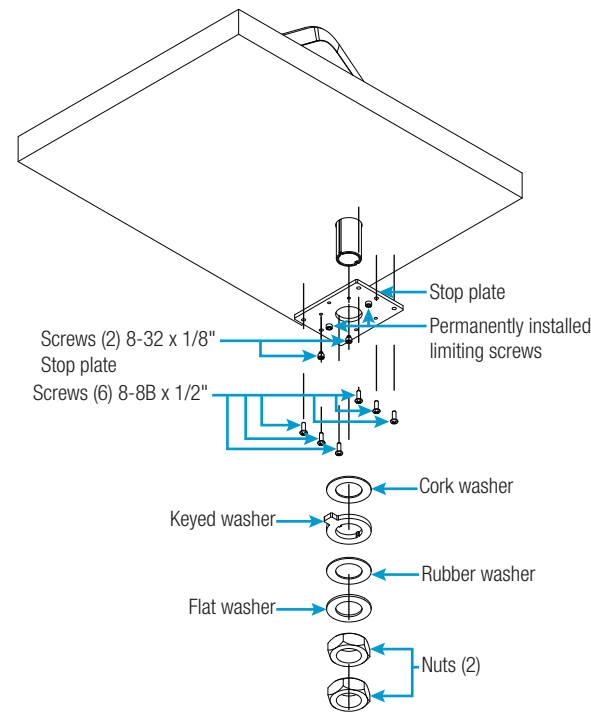

NOTE: The keyed washer limits the swivel range to approximately 180 degrees. The swivel range can be further limited by installing additional cap screws in the stop plate. Refer to "DO Customize the Swivel Range" for instructions.

2. Tighten the upper nut to achieve the desired resistance in the swivel motion. Use a flat tool, such as a large, flat-head screwdriver in the slot on the bottom of the swivel tube to hold the tube in place while tightening the nut.
3. Manually tighten the lower nut to the upper nut to prevent the upper nut from slipping.

DO Customize the Swivel Range (Optional)

Two additional 8-32 x 1/8" screws are included to further customize the swivel range. Refer to the following illustrations for details on customizing the swivel range.

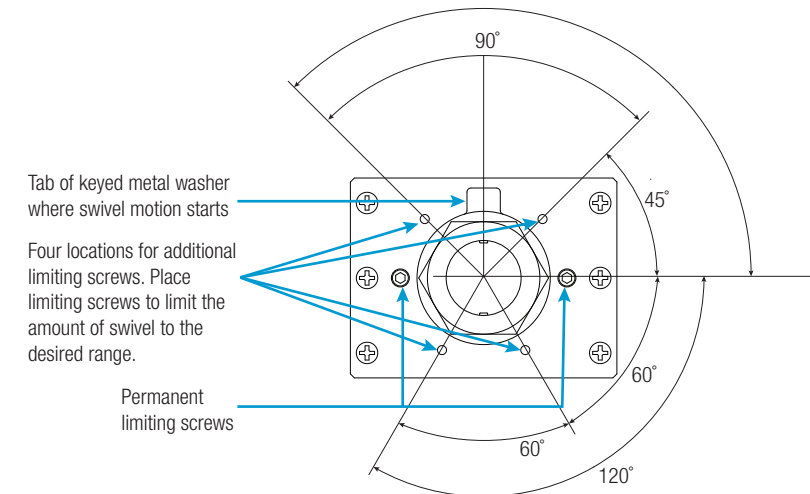

DO Complete the Installation

If the HDMI cable extender was used, connect the HDMI output cable to the HDMI cable extender. Use tie wraps on both ends of the connection to secure the cable connection to the other cables exiting the swivel tube.

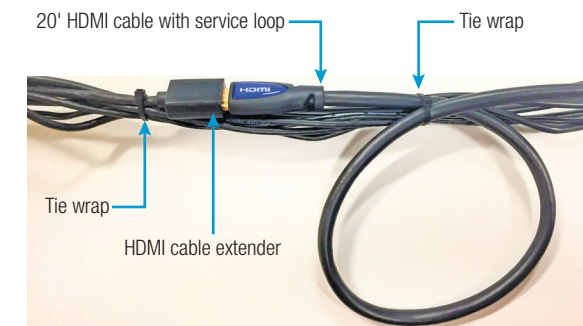

DO Learn More

Visit the website for additional information and the latest firmware updates. To learn more about this product, use a QR reader application on your mobile device to scan the QR image.

Crestron Electronics
15 Volvo Drive, Rockleigh, NJ 07647
888.CRESTRON | www.crestron.com



CE As of the date of manufacture, the product has been tested and found to comply with specifications for CE marking.

Federal Communications Commission (FCC) Compliance Statement

This device complies with part 15 of the FCC Rules. Operation is subject to the following two conditions:

- (1) This device may not cause harmful interference, and (2) this device must accept any interference received, including interference that may cause undesired operation.

CAUTION: Changes or modifications not expressly approved by the manufacturer responsible for compliance could void the user's authority to operate the equipment.

NOTE: This equipment has been tested and found to comply with the limits for a Class B digital device, pursuant to part 15 of the FCC Rules. These limits are designed to provide reasonable protection against harmful interference in a residential installation. This equipment generates, uses and can radiate radio frequency energy and, if not installed and used in accordance with the instructions, may cause harmful interference to radio communications. However, there is no guarantee that interference will not occur in a particular installation.

If this equipment does cause harmful interference to radio or television reception, which can be determined by turning the equipment off and on, the user is encouraged to try to correct the interference by one or more of the following measures:

- Reorient or relocate the receiving antenna.
- Increase the separation between the equipment and receiver.
- Connect the equipment into an outlet on a circuit different from that to which the receiver is connected.
- Consult the dealer or an experienced radio/TV technician for help.

Industry Canada (IC) Compliance Statement

CAN ICES-3(B)/NMB-3(B)

Crestron product development software is licensed to Crestron dealers and Crestron Service Providers (CSPs) under a limited non-exclusive, non-transferable Software Development Tools License Agreement. Crestron product operating system software is licensed to Crestron dealers, CSPs, and end-users under a separate End-User License Agreement. Both of these Agreements can be found on the Crestron website at www.crestron.com/legal/software_license_agreement.

The specific patents that cover Crestron products are listed at www.crestron.com/legal/patents.

Certain Crestron products contain open source software. For specific information, visit www.crestron.com/legal/open-source-software.

Crestron, the Crestron logo, and Crestron Mercury are either trademarks or registered trademarks of Crestron Electronics, Inc., in the United States and/or other countries. HDMI is either a trademark or registered trademark of HDMI Licensing LLC in the United States and/or other countries. Other trademarks, registered trademarks, and trade names may be used in this document to refer to either the entities claiming the marks and names or their products. Crestron disclaims any proprietary interest in the marks and names of others. Crestron is not responsible for errors in typography or photography.

This document was written by the Technical Publications department at Crestron.

©2017 Crestron Electronics, Inc.

The product warranty can be found at www.crestron.com/legal/sales-terms-conditions-warranties.