

Horizon™ In-Wall Switch with infiNET EX® Wireless Communication, 120 VAC

The Crestron® [HZ-SWEX](#) Horizon™ in-wall switch features the following:

- infiNET EX® Wireless Communication to Crestron Gateway (CEN-GWEXER)
- Field replaceable, engravable button caps available in various sizes (not supplied)
- REM input for multiway control for up to four HZ-KPEX or HZ-AUX devices

The HZ-SWEX controls incandescent, magnetic low voltage, electronic ballast, and tungsten-halogen transformer loads as well as 1/2 HP motors. The device offers the following load ratings:

- Input Rating: 120 VAC (Requires Neutral Wire Connection)
- Output Rating: 10 A Max. (No Minimum Load)



In the Box

- 1 HZ-SWEX, Horizon™ In-Wall Switch with infiNET EX® Wireless Communication, 120 VAC

Additional Items

- 2 Screw, 6-32 x 1 in., Truss Head, Combo (2054883)
- 1 Spacer, Multi-Gang Alignment (2049924)
- 1 Nut, Wire, Red (2053634)

Horizon™ In-Wall Switch with infiNET EX® Wireless Communication, 120 VAC



Important Notes

WARNINGS:

- To avoid fire, shock, or death, turn off power at circuit breaker or fuse and test that power is off before wiring!
- New installations should be checked for short circuits prior to installing an HZ-SWEX switch. With power off, close the circuit and restore power. If the lights do not work or a breaker trips, check and correct the wiring or fixture (if necessary). Install the dimmer only when the short is no longer present. The warranty is void if the dimmer is installed and operated with a shorted load.

CAUTION: TO REDUCE THE RISK OF OVERHEATING AND POSSIBLE DAMAGE TO OTHER EQUIPMENT, DO NOT INSTALL TO CONTROL A RECEPTACLE, A MOTOR-OPERATED APPLIANCE, A FLUORESCENT LIGHTING FIXTURE, OR A TRANSFORMER-SUPPLIED APPLIANCE.

ATTENTION: GRADATEURS COMMANDANT UN BALLAST-AFIN DE RÉDUIRE LE RISQUE DE SURCHAUFFE ET LA POSSIBILITÉ D'ENDOMMAGEMENT À D'AUTRES MATÉRIELS, NE PAS INSTALLER POUR COMMANDER UNE PRISE, UN APPAREIL D'ÉCLAIRAGE FLUORESCENT, UN APPAREIL OPÉRÉ DE MOTEUR OU UN APPAREIL ALIMENTÉ PAR UN TRANSFORMATEUR.

NOTES: Observe the following points.

- Neutral: The HZ-SWEX requires a neutral connection to operate.
- Codes: This product should be installed and used in accordance with appropriate electrical codes and regulations.
- Installation: This product should be installed by a qualified electrician.
- Wiring: Use copper wire only. For supply connections, use wires rated for at least 75° C (167° F).

- Lamp Type: For control of permanently installed incandescent, magnetic low voltage, tungsten-halogen, electronic ballasts, or 1/2 HP motors.
- Temperature: For use where temperatures are between 32° to 86° F (0° to 30° C).
- Electrical Boxes: Devices mount in standard electrical boxes. For easy installation, use 3-1/2 in. (89 mm) deep electrical boxes. Several devices can be installed in one electrical box (multigang). For a smooth appearance, one-piece multigang faceplates (not supplied) must be installed. When installing into a multigang box, do not fully tighten the devices to the box until the faceplate has been aligned.
- Switches: Mechanical 3- or 4-way switches do not work with HZ-SWEX series switches.
- Spacing: If mounting one device above another, leave at least 4-1/2 in. (115 mm) vertical space between them.
- Low Voltage Applications: Operation of a low voltage circuit with all lamps inoperative or removed may result in current flow in excess of normal levels. To avoid transformer overheating and premature transformer failure, Crestron recommends the following:
 - Do not operate low voltage circuits without operative lamps in place.
 - Replace burned-out lamps as quickly as possible.
 - Use transformers that incorporate thermal protection or fuse transformer primary windings to prevent transformer failure due to overcurrent.

Horizon™ In-Wall Switch with infiNET EX® Wireless Communication, 120 VAC



Installation

Install the HZ-SWEX:

1. Turn power off at the circuit breaker.

WARNING: If the HZ-SWEX is used with an HZ-AUX or HZ-KPEX, power may need to be turned off at multiple breakers.

2. Wire the device as shown in the following diagrams. In multigang installations, daisy-chain Hot and Neutral wires with other Horizon devices to eliminate excess wiring.

NOTE: To wire one or more HZ-AUX or HZ-KPEX, refer to the HZ-AUX Quick Start (Doc. 8485) or the HZ-KPEX Quick Start (Doc. 8284) at crestron.com/manuals.

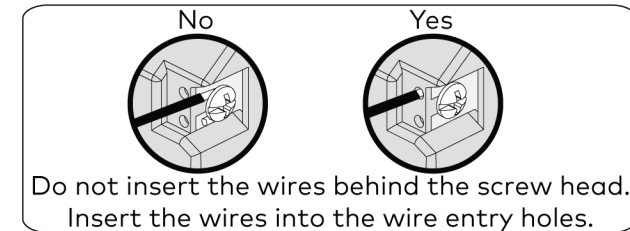
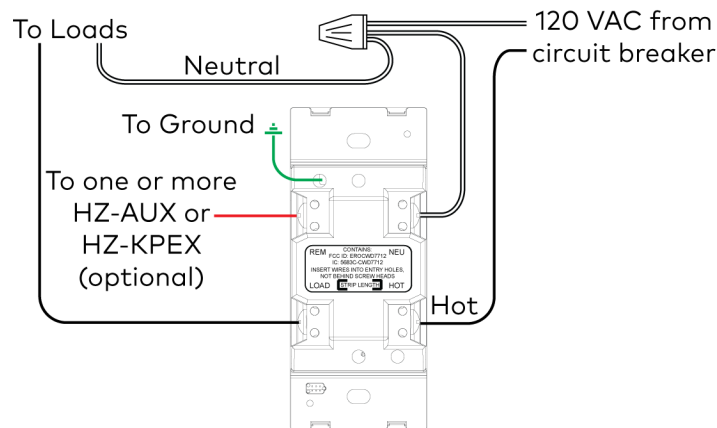

3. Fold the wires into the electrical box. Avoid pinched wires.
4. Secure the HZ-SWEX to the electrical box using the integrated mounting screws on the device. To allow for adjustments, do not fully tighten the screws at this time. Ensure that any text on the device is in the proper orientation and facing up.

CAUTION: Do not overtighten the screws when attaching the keypad to the electrical box. Damage to the unit and undesired functionality may occur.

5. Place the metal mounting bracket (not supplied) over the back of the HZ-SWEX. The two parts of the metal mounting bracket clip together which allows the wiring to remain in place.

NOTE: When installing the HZ-FP-G faceplate over an old work electrical box, do not use the metal mounting bracket.

6. Attach the HZ-FP-G series Horizon faceplate using the faceplate mounting screws. Ensure that the "Top" label is properly oriented.
7. Ensure that the HZ-SWEX is properly aligned within the HZ-FP-G and then fully tighten the integrated mounting screws to secure the device to the electrical box.
8. Attached the magnetic top and bottom trim pieces to the HZ-FP-G.
9. Ensure that all buttons actuate without sticking.
10. Restore power at the circuit breaker.

Horizon™ In-Wall Switch with infiNET EX® Wireless Communication, 120 VAC

HZ-SWEX Single Gang Installation

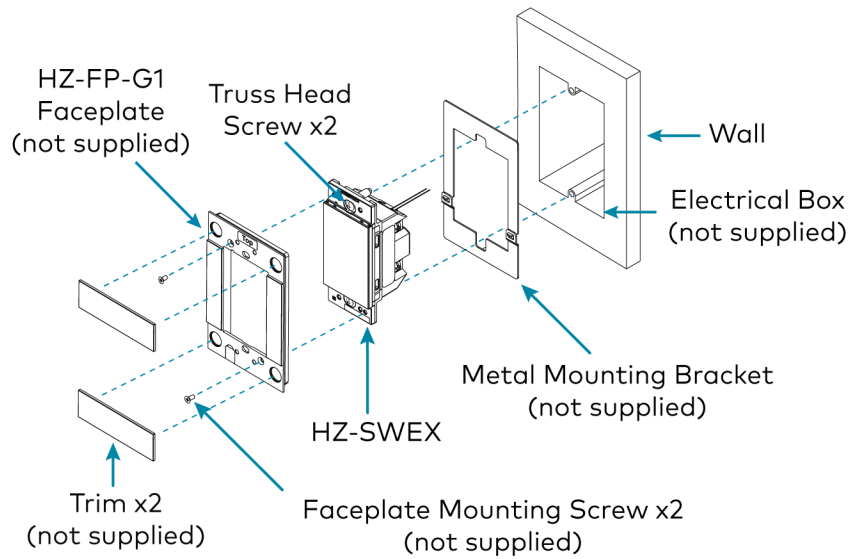

HZ-SWEX Multigang Installation

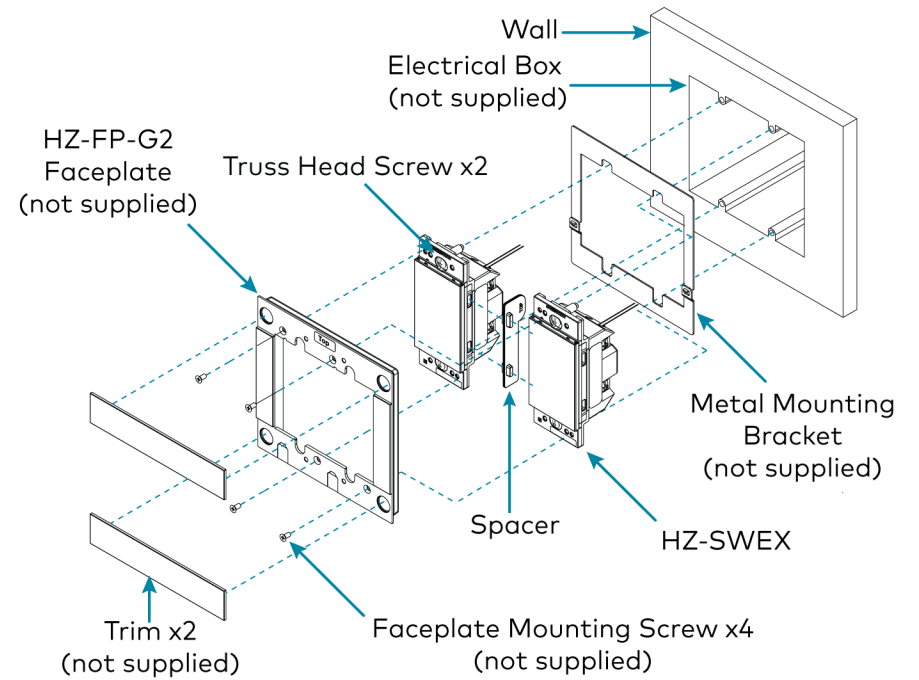

Horizon™ In-Wall Switch with infiNET EX® Wireless Communication, 120 VAC



Operation

NOTE: Before using the HZ-SWEX, ensure the device is using the latest firmware. Check for the latest firmware for the HZ-SWEX at www.crestron.com/firmware. Firmware is loaded onto the device using either Crestron Toolbox™ software or Crestron Home™ software.

Basic Operation

The operations in this guide assume the HZ-SWEX is operating with Local mode enabled (with or without a control system). The device can also operate in Remote mode, in which the control system program dictates button behavior and load control. The HZ-SWEX is shipped with a rocker button preinstalled, which functions as described below.

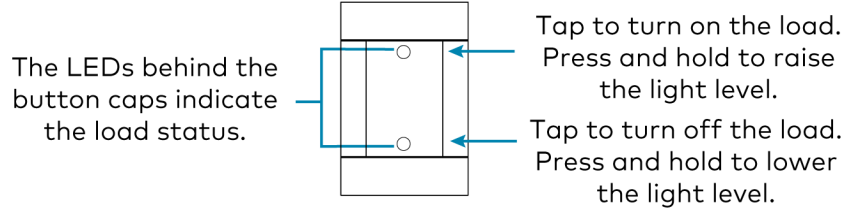

Default Button Functionality

The figure below illustrates the press and hold actuation sequences for each local button option as selected in programming. There is only one local button available per device.

Button behavior can be altered by the control system program. If the local button is disabled in the control system program and communication to the control system is lost, the device will default to the shown behavior. When enabled, the local button can still act as a remote trigger. However, LED feedback for the local button will be dictated only by the local load.

Default Local Button

On	On			Off	On	Off/On
		On				
	Off		On			
		Off				
Off			Off			

NOTE: The single push button or side-to-to-side rocker can be designated as the local button in any of the five available positions.

LED Behavior

The LEDs on the HZ-SWEX display the state of the connected loads and are located under each button cap.

Each LED can be in one of the following states:

- On: The load is powered.
- Off: The load is not powered.

NOTE: LED functionality for both local and remote behavior can be modified when programming the device.

Horizon™ In-Wall Switch with infiNET EX® Wireless Communication, 120 VAC

Multiway Operation

For more information on multiway operation, refer to the HZ-AUX Quick Start (Doc. 8485) or the HZ-KPEX Quick Start (Doc. 8284) at crestron.com/manuals.



Wireless Communications

The device connects to the Crestron network via the infiNET EX communications protocol. Use the following procedures to join or leave an infiNET EX network and to verify communications between the device and the control system.

NOTE: The HZ-SWEX is not compatible with the MC3 internal gateway when using channels 25 or 26.

Joining an infiNET EX Network

Before a device can be used in a lighting system, it must first join an infiNET EX network by being acquired by an infiNET EX gateway.

NOTE: A device can be acquired by only one gateway.

1. Put the infiNET EX gateway into Acquire mode from the unit itself or from Crestron Toolbox software, as described in the gateway's manual at www.crestron.com/manuals.

NOTE: In an environment where multiple gateways are installed, only one gateway should be in Acquire mode at any time.

2. Place the device into Acquire mode.
 - a. Tap the top button three times, and then press and hold it down (tap-tap-tap-press+hold) until all of the LEDs flash red once (this can take up to 10 seconds if the device has been previously acquired to a gateway).

NOTE: If a side-to-side rocker is in the top position, either side of the rocker can be pressed and held.

- b. Release the button to start the acquire process. The top button's LED flashes red slowly to show that the device is actively scanning the infiNET EX network.
 - The top button's LED lights red for 5 seconds to show that the device has been successfully acquired to the infiNET EX network.
 - The top button's LED flashes red quickly to indicate that the device was not successfully acquired by the infiNET EX network. Tap the setup button to acknowledge failure to acquire the infiNET EX network. Before attempting the acquire process again, ensure one of the following:
 - The gateway is in Acquire mode and within range.
 - A non-battery powered infiNET EX device is in Acquire mode on the same gateway.
3. Once all devices have been acquired, take the gateway out of Acquire mode. Refer to the gateway's manual for details.

Leaving an infiNET EX Network

To leave an infiNET EX network, put the device into Acquire mode. Ensure that no gateway is in Acquire mode when removing a device from an infiNET EX network.

To place a device into Acquire mode, refer to step 2 in [Joining an infiNET EX Network](#).

Horizon™ In-Wall Switch with infiNET EX® Wireless Communication, 120 VAC

Verifying Communications Status

To check the communications status of the device, tap the top button three times and then press and hold it down (tap-tap-tap-press+hold) for up to 2 seconds. The button must be released before the LEDs flash to indicate the communications status. Refer to the following table for details.

NOTES:

- If a side-to-side rocker is in the top position, either side of the rocker can be pressed and held.
- If there is a communication error and a remote button is pressed, all of the LEDs will flash red in one of the patterns described in the table below.

LED	Communications Status
Turns on for 5 seconds	The device is communicating with the control system.
Flashes three times	The device is communicating with the gateway, but the gateway is not communicating with the control system.
Flashes twice	The device was previously joined to the network but is not communicating with the gateway.
Flashes once	The device is not joined to the network.



Ambient Light Sensor Calibration

An LED backlight behind each button illuminates engravings. The ambient light sensor adjusts the backlight brightness according to the light level in the room. The ambient light sensor can be affected by room conditions and should be calibrated manually (locally or through programming), or the appropriate setting can be changed in control system programming.

To locally calibrate the light sensor:

1. Ensure that all room lights are fully on.
2. Ensure the faceplate and bottom trim piece are installed correctly. Remove the top trim piece.
3. Press and hold the setup button with a small pointed object for about 2 seconds until all keypad backlights flash magenta. This can also be triggered in programming.
4. Avoid blocking the light sensor on the bottom of the HZ-SWEX. The light sensor should remain unobstructed and free of direct light. After about 5 seconds, the calibration process is complete. The keypad returns to normal operation.

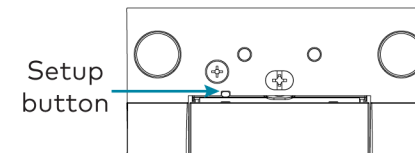

Horizon™ In-Wall Switch with infiNET EX® Wireless Communication, 120 VAC



Backlight Customization

Backlight color customization can be accomplished locally or through programming.

NOTE: Custom and preset color themes may be defined in the control system program. Custom programming will override local settings.

To locally change the color of the LED backlights:

1. Press the setup button with a small pointed object once. The LED backlights will light brightly for 15 seconds.
2. Press the setup button repeatedly to cycle through the backlight color options.



Troubleshooting

The module displays error codes using the dimmer output LEDs. The LED flashes a pattern to indicate the error on that output. For example, a 2-1 error flashes the LED two times, pauses for 1 second, flashes once, pauses for 2 seconds, and then repeats for 90 seconds (except where otherwise noted). Refer to the following table for possible corrections.

Error Code	Fault Name	Fault Description
2-3	Over Temperature	The dimmer has overheated and shut down due to an excessive load. Verify that the total load matches the proper ganged rating. The dimmer resumes normal operation after cooling.
3-3	Device Error	The device is experiencing a hardware issue. Please contact Crestron Technical Support.

For general troubleshooting, please refer to the following table:

Trouble	Probable Cause(s)	Corrective Action
The device does not function.	The device is not receiving power.	Verify that the power connections are correct and that the circuit breaker is closed.
	The load is not operational (e.g. lamps are burned out).	Verify that the load is operational.
	The button(s) being used are not set to control the local load.	Check the program to verify that at least one button is programmed to control the local load.
	The neutral wire is not connected to the device.	Connect a dedicated neutral wire to the device.

Horizon™ In-Wall Switch with infiNET EX® Wireless Communication, 120 VAC



Visit the Product Page

Scan the QR code to visit the product page.



www.crestron.com/model/6509598

Additional Information

Original Instructions

The U.S. English version of this document is the original instructions. All other languages are a translation of the original instructions.

Crestron product development software is licensed to Crestron dealers and Crestron Service Providers (CSPs) under a limited nonexclusive, nontransferable Software Development Tools License Agreement. Crestron product operating system software is licensed to Crestron dealers, CSPs, and end-users under a separate End-User License Agreement. Both of these Agreements can be found on the Crestron website at www.crestron.com/legal/software_license_agreement.

The product warranty can be found at www.crestron.com/warranty.

The specific patents that cover Crestron products are listed at www.crestron.com/legal/patents.

Certain Crestron products contain open source software. For specific information, visit www.crestron.com/opensource.

Crestron, the Crestron logo, Crestron Home, Crestron Toolbox, Horizon, and infiNET EX are either trademarks or registered trademarks of Crestron Electronics, Inc. in the United States and/or other countries. Other trademarks, registered trademarks, and trade names may be used in this document to refer to either the entities claiming the marks and names or their products. Crestron disclaims any proprietary interest in the marks and names of others. Crestron is not responsible for errors in typography or photography.

©2020 Crestron Electronics, Inc.

Doc ID 8282B

03/25/20