

Crestron **TPS-6X-IMCW**
Interface Module

Installation Guide



This document was prepared and written by the Technical Documentation department at:



Crestron Electronics, Inc.
15 Volvo Drive
Rockleigh, NJ 07647
1-888-CRESTRON

Regulatory Compliance

As of the date of manufacture, the TPS-6X-IMCW has been tested and found to comply with specifications for CE marking and standards per EMC and Radiocommunications Compliance Labelling.



Federal Communications Commission (FCC) Compliance Statement

This device complies with part 15 of the FCC Rules. Operation is subject to the following conditions:
(1) This device may not cause harmful interference and (2) this device must accept any interference received, including interference that may cause undesired operation.

CAUTION: Changes or modifications not expressly approved by the manufacturer responsible for compliance could void the user's authority to operate the equipment.

NOTE: This equipment has been tested and found to comply with the limits for a Class B digital device, pursuant to part 15 of the FCC Rules. These limits are designed to provide reasonable protection against harmful interference in a residential installation. This equipment generates, uses and can radiate radio frequency energy and, if not installed and used in accordance with the instructions, may cause harmful interference to radio communications. However, there is no guarantee that interference will not occur in a particular installation. If this equipment does cause harmful interference to radio or television reception, which can be determined by turning the equipment off and on, the user is encouraged to try to correct the interference by one or more of the following measures:

- Reorient or relocate the receiving antenna
- Increase the separation between the equipment and receiver
- Connect the equipment into an outlet on a circuit different from that to which the receiver is connected
- Consult the dealer or an experienced radio/TV technician for help

Industry Canada (IC) Compliance Statement

This Class B digital apparatus complies with Canadian ICES-003.

Cet appareil numérique de la classe B est conforme à la norme NMB-003 du Canada.

Contents

Interface Module for TPS-6X-DS: TPS-6X-IMCW	1
Introduction	1
Features and Functions	1
Specifications	2
Physical Description	4
Setup	9
Network Wiring	9
Supplied Hardware	10
Installation	11
Hardware Hookup	13
Problem Solving	16
Troubleshooting	16
Check Network Wiring	17
Further Inquiries	18
Future Updates	18
Return and Warranty Policies	19
Merchandise Returns / Repair Service	19
CRESTRON Limited Warranty	19

Interface Module: TPS-6X-IMCW

Introduction

The TPS-6X-IMCW is the interface module that is included as standard with the Isys™ TPS-6 Tilt Touchpanel, TPS-6X Series Wireless Touchpanels and TPS-6X-DS and TPS-6XNL-DS Docking Stations. It provides a convenient pluggable connection for the docking station via a single 10-pin RJ-50 jack on its front panel. On the rear are connections for Cresnet®, Ethernet, balanced or unbalanced video and a choice of Cresnet or local DC power. An additional DC power jack is included on the front panel to simplify the connection of a local power supply in a typical wall mount application.

Using the hardware provided, the TPS-6X-IMCW can be mounted in a standard 1-gang electrical box, to a flat surface or to a 19-inch rack rail. Multiple TPS-6X-IMCW interface modules may be purchased individually and installed as part of a complete system to provide multiple connection locations.

Features and Functions

- Single wire connection for the TPS-6, TPS-6X Series and TPS-6X-DS and TPS-6XNL-DS docking stations
- Mounts in a single-gang wall box
- Includes inserts to match black or white faceplates
- Surface mount and rack rail installation options included
- Wired Ethernet and Cresnet control system connections
- Balanced or coaxial video input
- Versatile powering options

Specifications

Specifications for the TPS-6X-IMCW are listed in the following table.

TPS-6X-IMCW Specifications

SPECIFICATION	DETAILS
Power Requirements*	
Power Pack	0.75 Amps @ 24 Volts DC (power pack sold separately)
Cresnet Power Usage	0.5 Watts (0.02 Amps @ 24 Volts DC), module only; 18 Watts (0.75 Amps @ 24 Volts DC), with TPS-6 or TPS-6X Series touchpanel connected
Environmental	
Temperature	32° to 112°F (0° to 45°C)
Humidity	10% to 90% RH (non-condensing)
Heat Dissipation	61 BTU/Hr
Enclosure	
Construction	Metal, black matte powder coat finish, includes (2) metal inserts to allow choice of black or white front panel
Flush Wall Mount	1-gang mountable in a standard electrical box, 2.5 inch (64 mm) deep minimum; requires third- party decorative faceplate (not included)
Surface Mount	Surface mount bracket included
Rack Mount	Mountable to a single 19-inch EIA rack rail

(Continued on following page)

TPS-6X-IMCW Specifications (Continued)

SPECIFICATION	DETAILS
Dimensions	
Height	4.11 in (105 mm)
Width	1.72 in (44 mm) 1.93 in (49 mm) with surface mount bracket
Depth	1.43 in (37 mm) 1.49 in (38 mm) with surface mount bracket
Weight	6 oz (162 g) 9 oz (232 g) with bracket
Available Accessories	
Power Pack	24 Volt Power Pack, Universal

* May be powered by power pack (sold separately) or Cresnet network power, not both.

Physical Description

This section provides information on the connections, controls and indicators available on your TPS-6X-IMCW.

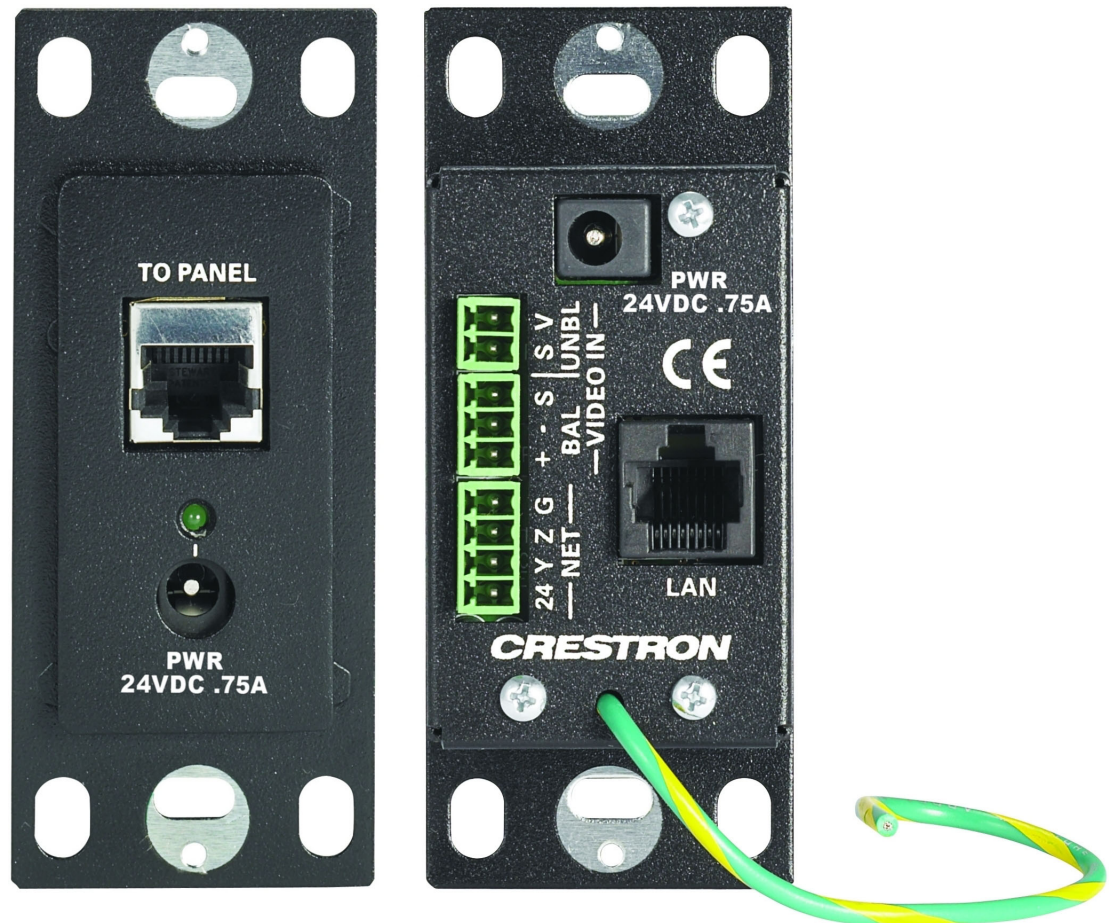

TPS-6X-IMCW Physical View

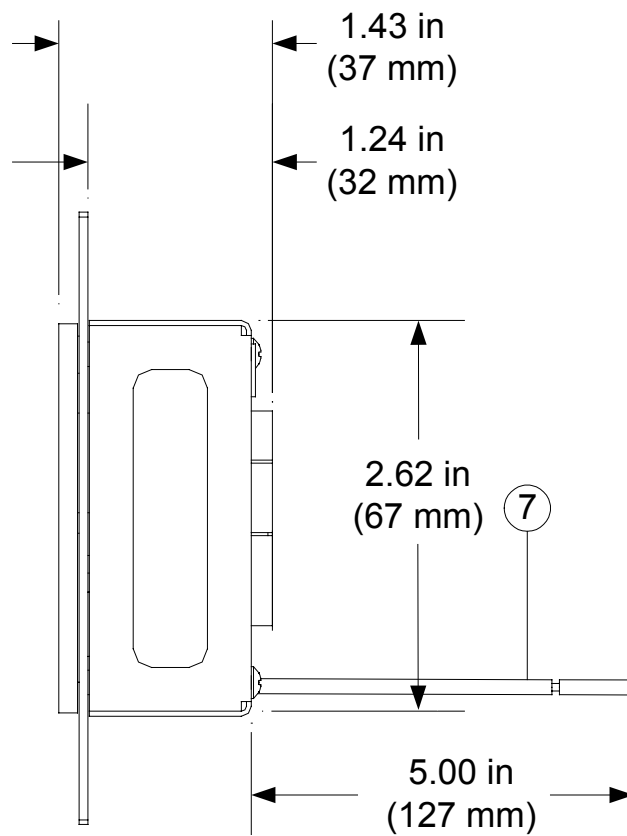
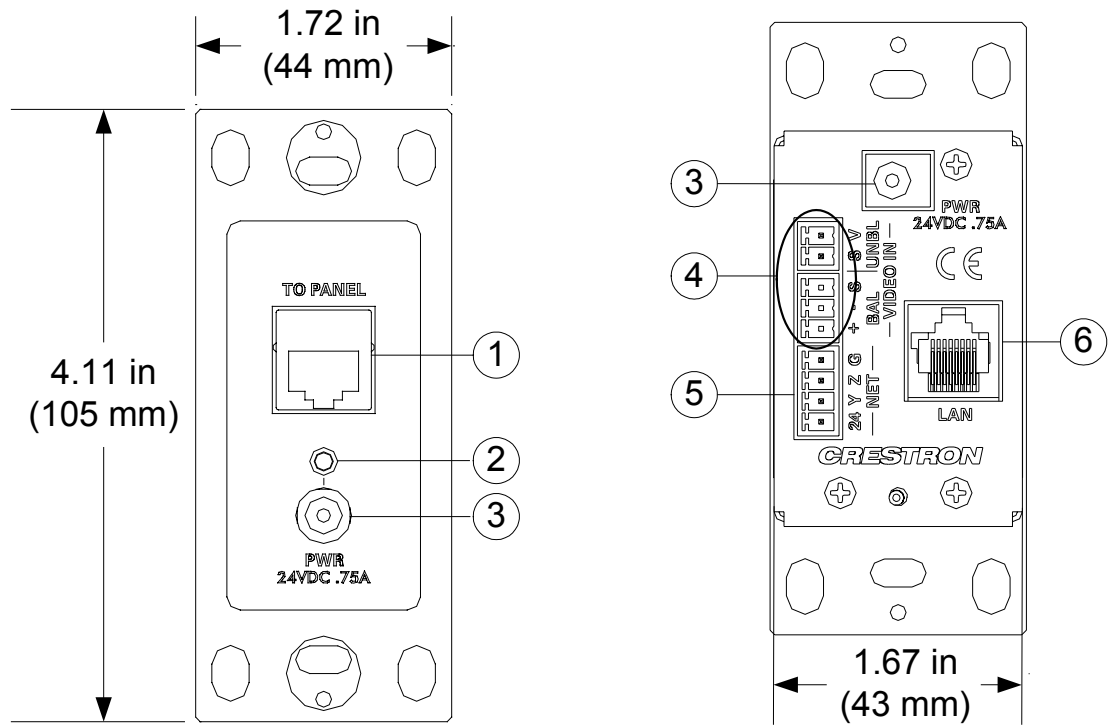

TPS-6X-IMCW Overall Dimensions



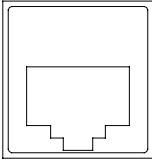

Connectors, Controls & Indicators

#	CONNECTORS ¹ , CONTROLS & INDICATORS	DESCRIPTION																																			
1	TO PANEL 	(1) 10-wire RJ-50 female; Connection for TPS-6 touchpanel or TPS-6X Series docking station <table border="1"> <thead> <tr> <th>TYPE</th> <th>PIN</th> <th>COLOR</th> <th>SIGNALS</th> </tr> </thead> <tbody> <tr> <td rowspan="10">10-Position RJ-50</td> <td>1</td> <td>Gray</td> <td>Ground</td> </tr> <tr> <td>2</td> <td>Orange/ White</td> <td>Ethernet TX+</td> </tr> <tr> <td>3</td> <td>Orange</td> <td>Ethernet TX-</td> </tr> <tr> <td>4</td> <td>Green/ White</td> <td>Ethernet RX+</td> </tr> <tr> <td>5</td> <td>Blue</td> <td>Cresnet Y</td> </tr> <tr> <td>6</td> <td>Blue/ White</td> <td>Cresnet Z</td> </tr> <tr> <td>7</td> <td>Green</td> <td>Ethernet RX-</td> </tr> <tr> <td>8</td> <td>Brown/ White</td> <td>Diff Video +</td> </tr> <tr> <td>9</td> <td>Brown</td> <td>Diff Video -</td> </tr> <tr> <td>10</td> <td>Gray/ White</td> <td>Power 24V</td> </tr> </tbody> </table>	TYPE	PIN	COLOR	SIGNALS	10-Position RJ-50	1	Gray	Ground	2	Orange/ White	Ethernet TX+	3	Orange	Ethernet TX-	4	Green/ White	Ethernet RX+	5	Blue	Cresnet Y	6	Blue/ White	Cresnet Z	7	Green	Ethernet RX-	8	Brown/ White	Diff Video +	9	Brown	Diff Video -	10	Gray/ White	Power 24V
TYPE	PIN	COLOR	SIGNALS																																		
10-Position RJ-50	1	Gray	Ground																																		
	2	Orange/ White	Ethernet TX+																																		
	3	Orange	Ethernet TX-																																		
	4	Green/ White	Ethernet RX+																																		
	5	Blue	Cresnet Y																																		
	6	Blue/ White	Cresnet Z																																		
	7	Green	Ethernet RX-																																		
	8	Brown/ White	Diff Video +																																		
	9	Brown	Diff Video -																																		
	10	Gray/ White	Power 24V																																		
2	PWR LED	(1) Green LED, indicates DC power supplied from Cresnet network or DC power pack																																			
3	PWR 24VDC .75A ² 	(1 on front panel and 1 on back panel) 2.1 mm barrel DC power jack; 24 Volt DC power input; (power supply sold separately)																																			

(Continued on following page)

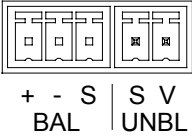
Connectors, Controls, & Indicators (Continued)

#	CONNECTORS ¹ , CONTROLS & INDICATORS	DESCRIPTION
4	<p>VIDEO IN³</p> 	<p>(1) 3-pin 3.5 mm detachable terminal block; Balanced composite video input; Input impedance: 100 Ω nominal; Input level: 1 V_{p-p} nominal, 1.5 V_{p-p} maximum; Maximum DC offset: ±2 Volts; Connects to any Creston CAT5 video out port via CresCAT cable</p> <p>(1) 2-pin 3.5 mm detachable terminal block; Unbalanced composite video input; Input impedance: 75 Ω nominal Input level: 1 V_{p-p} nominal, 1.5 V_{p-p} maximum; Maximum DC offset: ±2 Volts; Connects to any conventional coax video source</p>
5	<p>NET²</p> 	<p>(1) 4-pin 3.5 mm detachable terminal block; Cresnet slave port, connects to Cresnet control network</p> <p>24: Power (24 Volts DC) Y: Data Z: Data G: Ground</p>

(Continued on following page)

Connectors, Controls, & Indicators (Continued)

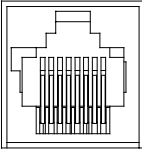
#	CONNECTORS ¹ , CONTROLS & INDICATORS	DESCRIPTION																				
6	<p>LAN</p> 	<p>(1) 8-wire RJ-45; 10/100BASE-T Ethernet port</p> <table border="1"> <thead> <tr> <th>TYPE</th> <th>PIN</th> <th>SIGNALS</th> </tr> </thead> <tbody> <tr> <td rowspan="8">8-Position RJ-45</td> <td>1</td> <td>TD+</td> </tr> <tr> <td>2</td> <td>TD-</td> </tr> <tr> <td>3</td> <td>RD+</td> </tr> <tr> <td>4</td> <td>N/C</td> </tr> <tr> <td>5</td> <td>N/C</td> </tr> <tr> <td>6</td> <td>RD-</td> </tr> <tr> <td>7</td> <td>N/C</td> </tr> <tr> <td>8</td> <td>N/C</td> </tr> </tbody> </table>	TYPE	PIN	SIGNALS	8-Position RJ-45	1	TD+	2	TD-	3	RD+	4	N/C	5	N/C	6	RD-	7	N/C	8	N/C
TYPE	PIN	SIGNALS																				
8-Position RJ-45	1	TD+																				
	2	TD-																				
	3	RD+																				
	4	N/C																				
	5	N/C																				
	6	RD-																				
	7	N/C																				
	8	N/C																				
7	GROUND ⁴	(1) Flying lead, grounding wire																				

1. Interface connectors for **NET** and **VIDEO IN** ports are provided with the unit.
2. May be powered by power pack (sold separately) or Cresnet network power, not both. Be sure to use a Crestron approved power supply as another may cause damage.
3. Balanced and unbalanced video inputs are mutually exclusive.
4. A grounding lead is provided for connection to earth ground (building steel). This ground connection is recommended to provide a common ground reference for signals provided to the TPS6X-IMCW, notably video inputs and to reduce the incidence of possible damage to the unit from static discharge.

Setup

Network Wiring

When wiring the Cresnet and Ethernet network, consider the following:

- Use Crestron Certified Wire.
- Use Crestron power supplies for Crestron equipment.
- Provide sufficient power to the system.

CAUTION: Insufficient power can lead to unpredictable results or damage to the equipment. Please use the Crestron Power Calculator to help calculate how much power is needed for the system (www.crestron.com/calculators).

Cresnet

For networks with 20 or more devices, use a Cresnet Hub/Repeater (CNXHUB) to maintain signal quality.

For more details, refer to “Check Network Wiring” which starts on page 17.

Ethernet

The TPS-6X-IMCW can also use high-speed Ethernet for communications between the device and a control system, computer, digital media server and other IP-based devices.

For information on connecting Ethernet devices in a Crestron system, refer to the latest version of the Crestron e-Control[®] Reference Guide (Doc. 6052), which is available from the Crestron website (www.crestron.com/manuals).

Supplied Hardware

The hardware supplied with the TPS-6X-IMCW is listed in the following table.

Supplied Hardware for the TPS-6X-IMCW

DESCRIPTION	PART NUMBER	QTY
Assy, Insert, Black	4503186	1
Assy, Insert, White	4503188	1
Metal, Bracket, 16 GA CRS	2016054	1
Conn, Plug, 2-pin, SKT, Single Row	2003574	1
Conn, Plug, 3-pin, SKT, Single Row	2003575	1
Conn, Plug, 4-pin, SKT, Single Row	2003576	1
Hole Plug, Ferrule Dust Cap, Blk	2017028	1
Screw, #06-32 x 1", Flat, Slot	2013235	2
Screw, #06-32 x 3/16", Pan, Phil	2007203	2

Installation

The TPS-6X-IMCW can be installed in either a 1-gang box, rack mounted or mounted to any flat surface using the provided surface mount bracket.

**Installing in
1-Gang Box**

To install the TPS-6X-IMCW in a 1-gang box, ensure the unit is mounted into the electrical box as shown in the following illustration.

TPS-6X-IMCW 1-Gang Box – Exploded View

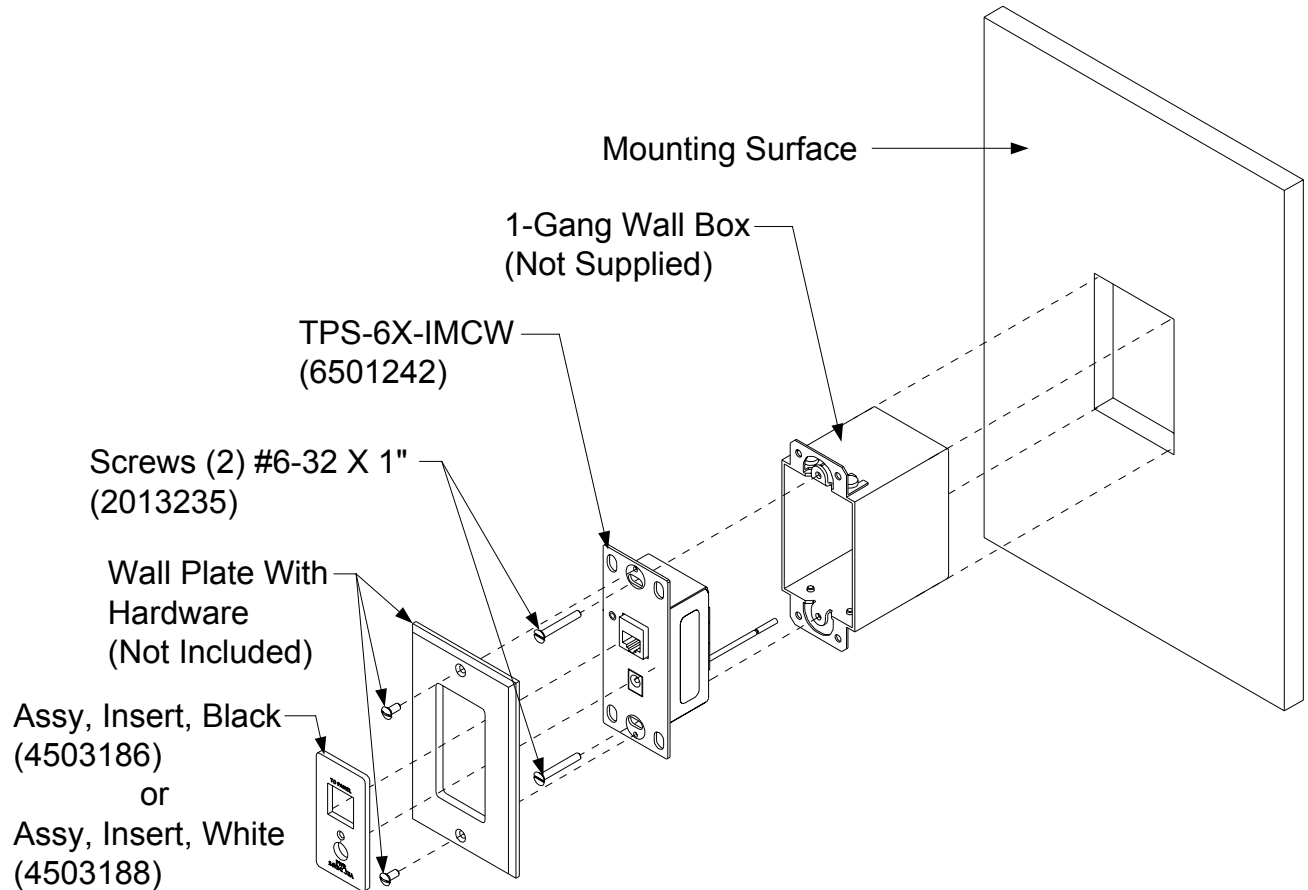

**Rack
Mounting**

The TPS-6X-IMCW can be mounted in a rack with other equipment using the four mounting holes on the corners of the interface module, as shown in the following illustration.

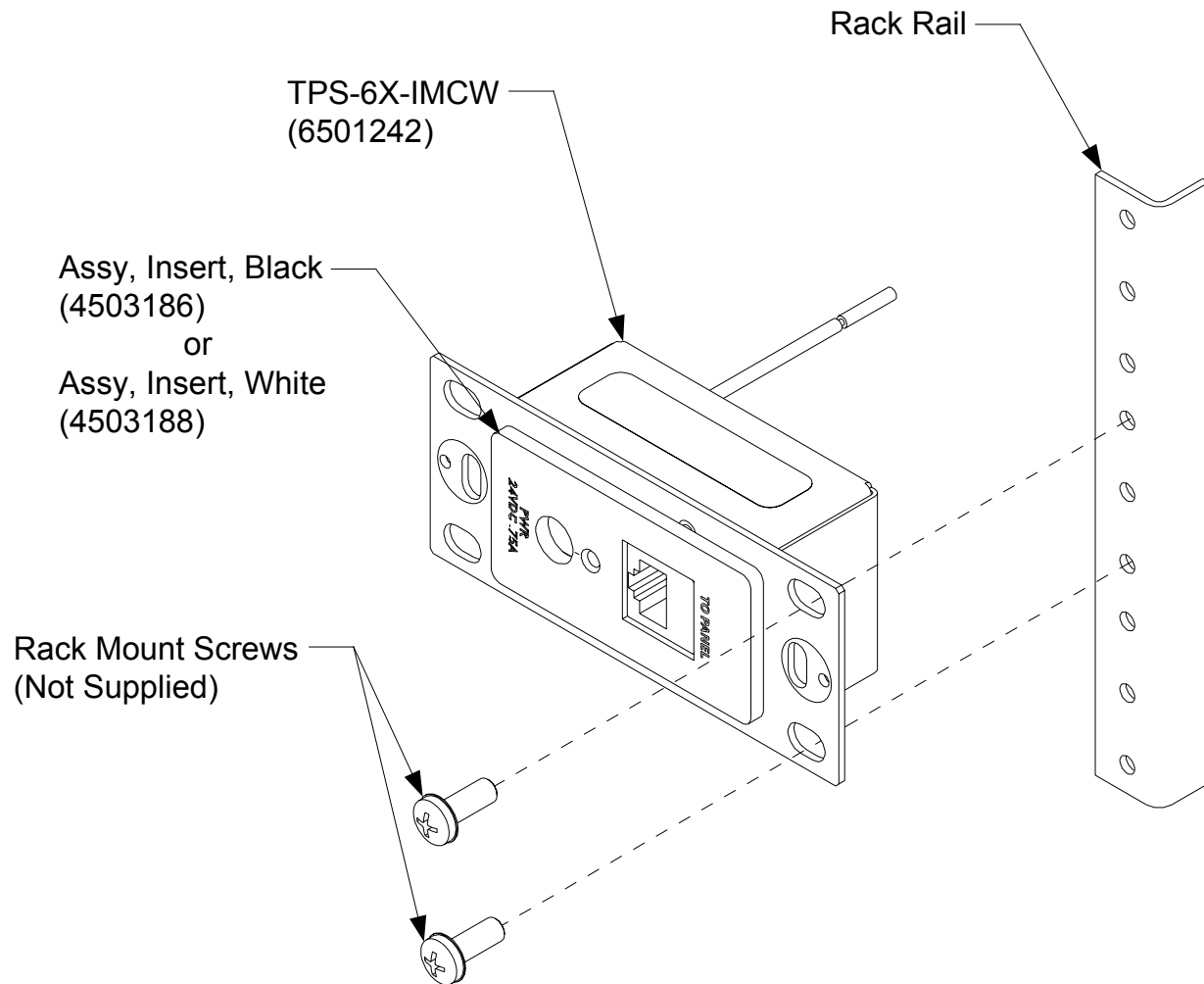
TPS-6X-IMCW Rack Mount – Exploded View

WARNING: To prevent bodily injury when mounting or servicing this unit in a rack, take special precautions to ensure that the system remains stable. The following guidelines are provided to ensure your safety:

- When mounting this unit in a partially filled rack, load the rack from the bottom to the top with the heaviest component at the bottom of the rack.
 - If the rack is provided with stabilizing devices, install the stabilizers before mounting or servicing the unit in the rack.
-

*Installing on
a Level
Surface*

To prepare the TPS-6X-IMCW to be mounted onto a level surface, ensure the unit is attached to the surface mount bracket, as shown in the following illustration.

TPS-6X-IMCW Bracket Mount – Exploded View

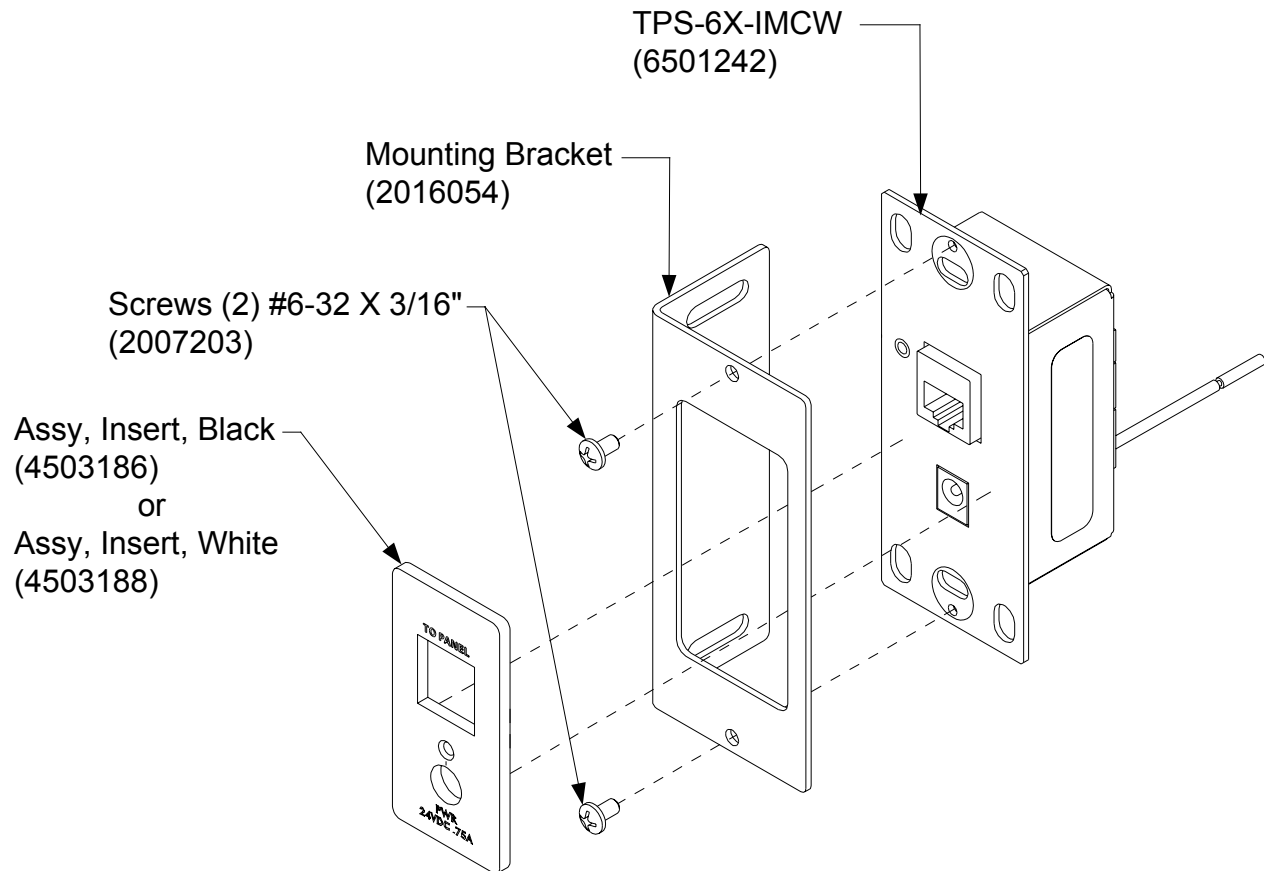

Hardware Hookup

Make the necessary connections as called out in the illustration on the following page. Refer to “Network Wiring” on page 9 before attaching the 4-position terminal block connector. Apply power after all connections have been made.

When making connections to the TPS-6X-IMCW, use Crestron power supplies for Crestron equipment.

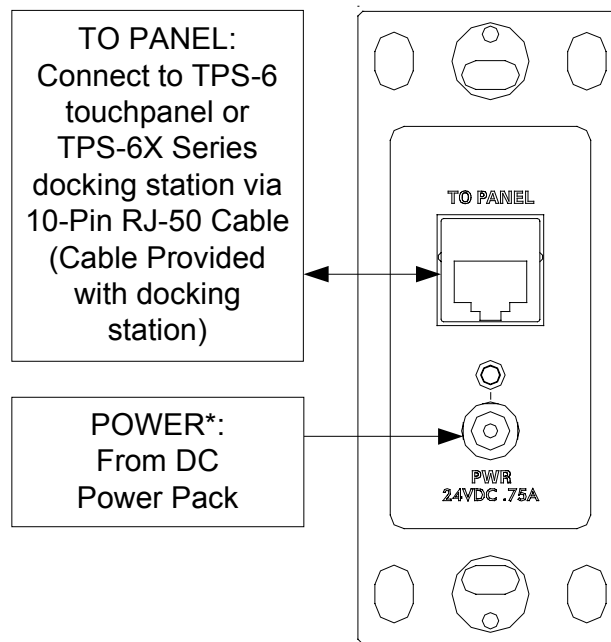
Hardware Connections for the TPS-6X-IMCW (Front)

* A ferrule dust cap (2017028) is provided to cover the front panel DC power jack when not in use.

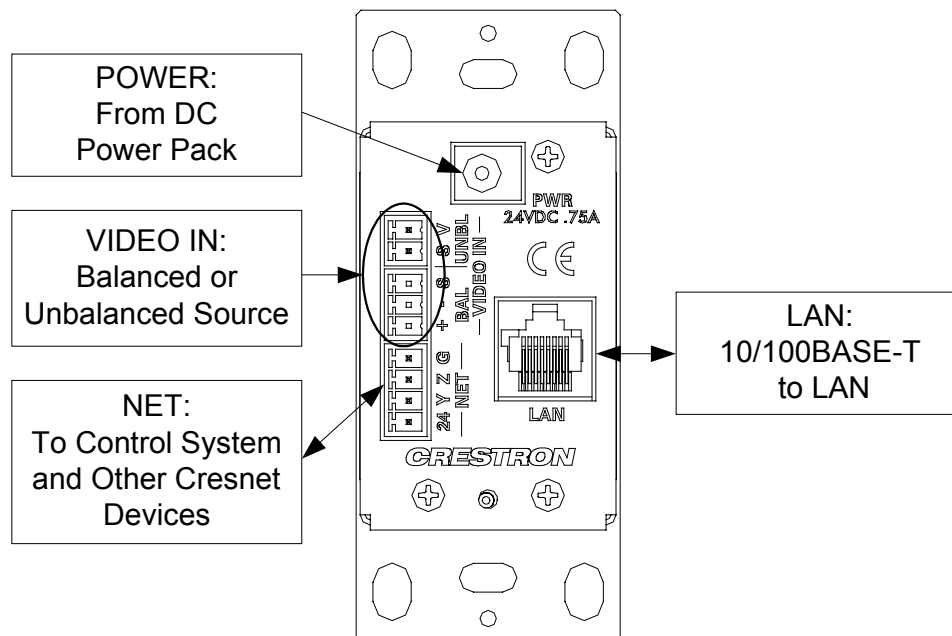
Hardware Connections for the TPS-6X-IMCW (Back)

NOTE: Ensure the unit is properly grounded by connecting the chassis ground lug to an earth ground (building steel).

NOTE: The TPS-6X-IMCW can be powered via the **PWR** jack on either the front or the back of the unit if the **NET** port is not being used to power the module.

Problem Solving

Troubleshooting

The following table provides corrective action for possible trouble situations. If further assistance is required, please contact a Crestron customer service representative.

TPS-6X-IMCW Troubleshooting

TROUBLE	POSSIBLE CAUSE(S)	CORRECTIVE ACTION
Device does not function.	Device is not receiving sufficient power.	Use a Crestron approved power source and verify connections.
		Use the Crestron Power Calculator to help calculate how much power is needed for the system.
PWR LED does not illuminate.	Device is not receiving sufficient power.	Use a Crestron approved power source and verify connections.
		Use the Crestron Power Calculator to help calculate how much power is needed for the system.
Loss of functionality due to electrostatic discharge.	Improper grounding.	Check that all ground connections have been made properly.

Check Network Wiring

Use the Right Wire

In order to ensure optimum performance over the full range of your installation topology, Crestron Certified Wire and only Crestron Certified Wire may be used. Failure to do so may incur additional charges if support is required to identify performance deficiencies because of using improper wire.

Calculate Power

CAUTION: Use only Crestron power supplies for Crestron equipment. Failure to do so could cause equipment damage or void the Crestron warranty.

CAUTION: Provide sufficient power to the system. Insufficient power can lead to unpredictable results or damage to the equipment. Please use the Crestron Power Calculator to help calculate how much power is needed for the system (www.crestron.com/calculators).

When calculating the length of wire for a particular Cresnet run, the wire gauge and the Cresnet power usage of each network unit to be connected must be taken into consideration. Use Crestron Certified Wire only. If Cresnet units are to be daisy-chained on the run, the Cresnet power usage of each network unit to be daisy-chained must be added together to determine the Cresnet power usage of the entire chain. If the unit is home-run from a Crestron system power supply network port, the Cresnet power usage of that unit is the Cresnet power usage of the entire run. The wire gauge and the Cresnet power usage of the run should be used in the following equation to calculate the cable length value on the equation's left side.

Cable Length Equation

$$L < \frac{40,000}{R \times P}$$

Where: L = Length of run (or chain) in feet
 R = 6 Ohms (Crestron Certified Wire: 18 AWG (0.75 MM²))
 or 1.6 Ohms (Cresnet HP: 12 AWG (4 MM²))
 P = Cresnet power usage of entire run (or chain)

Make sure the cable length value is less than the value calculated on the right side of the equation. For example, a Cresnet run using 18 AWG Crestron Certified Wire and drawing 20 watts should not have a length of run more than 333 feet. If Cresnet HP is used for the same run, its length could extend to 1250 feet.

NOTE: All Crestron certified Cresnet wiring must consist of two twisted pairs. One twisted pair is the +24V conductor and the GND conductor and the other twisted pair is the Y conductor and the Z conductor.

Strip and Tin Wire

When daisy-chaining Cresnet units, strip the ends of the wires carefully to avoid nicking the conductors. Twist together the ends of the wires that share a pin on the network connector and tin the twisted connection. Apply solder only to the ends of the twisted wires. Avoid tinning too far up the wires or the end becomes brittle. Insert the tinned connection into the Cresnet connector and tighten the retaining screw. Repeat the procedure for the other three conductors.

Add Hubs

For larger networks (i.e., greater than 28 network devices), it may become necessary to add a Cresnet Hub/Repeater (CNXHUB) to maintain signal quality throughout the network. Also, for networks with lengthy cable runs it may be necessary to add a Hub/Repeater after only 20 devices.

Further Inquiries

If you cannot locate specific information or have questions after reviewing this guide, please take advantage of Crestron's award winning customer service team by calling Crestron at 1-888-CRESTRON [1-888-273-7876].

You can also log onto the online help section of the Crestron website (www.crestron.com/onlinehelp) to ask questions about Crestron products. First-time users will need to establish a user account to fully benefit from all available features.

Future Updates

As Crestron improves functions, adds new features and extends the capabilities of the TPS-6X-IMCW, additional information may be made available as manual updates. These updates are solely electronic and serve as intermediary supplements prior to the release of a complete technical documentation revision.

Check the Crestron website periodically for manual update availability and its relevance. Updates are identified as an “Addendum” in the Download column.

Return and Warranty Policies

Merchandise Returns / Repair Service

1. No merchandise may be returned for credit, exchange or service without prior authorization from CRESTRON. To obtain warranty service for CRESTRON products, contact an authorized CRESTRON dealer. Only authorized CRESTRON dealers may contact the factory and request an RMA (Return Merchandise Authorization) number. Enclose a note specifying the nature of the problem, name and phone number of contact person, RMA number and return address.
2. Products may be returned for credit, exchange or service with a CRESTRON Return Merchandise Authorization (RMA) number. Authorized returns must be shipped freight prepaid to CRESTRON, 6 Volvo Drive, Rockleigh, N.J. or its authorized subsidiaries, with RMA number clearly marked on the outside of all cartons. Shipments arriving freight collect or without an RMA number shall be subject to refusal. CRESTRON reserves the right in its sole and absolute discretion to charge a 15% restocking fee plus shipping costs on any products returned with an RMA.
3. Return freight charges following repair of items under warranty shall be paid by CRESTRON, shipping by standard ground carrier. In the event repairs are found to be non-warranty, return freight costs shall be paid by the purchaser.

CRESTRON Limited Warranty

CRESTRON ELECTRONICS, Inc. warrants its products to be free from manufacturing defects in materials and workmanship under normal use for a period of three (3) years from the date of purchase from CRESTRON, with the following exceptions: disk drives and any other moving or rotating mechanical parts, pan/tilt heads and power supplies are covered for a period of one (1) year; touchscreen display and overlay components are covered for 90 days; batteries and incandescent lamps are not covered.

This warranty extends to products purchased directly from CRESTRON or an authorized CRESTRON dealer. Purchasers should inquire of the dealer regarding the nature and extent of the dealer's warranty, if any.

CRESTRON shall not be liable to honor the terms of this warranty if the product has been used in any application other than that for which it was intended or if it has been subjected to misuse, accidental damage, modification or improper installation procedures. Furthermore, this warranty does not cover any product that has had the serial number altered, defaced or removed.

This warranty shall be the sole and exclusive remedy to the original purchaser. In no event shall CRESTRON be liable for incidental or consequential damages of any kind (property or economic damages inclusive) arising from the sale or use of this equipment. CRESTRON is not liable for any claim made by a third party or made by the purchaser for a third party.

CRESTRON shall, at its option, repair or replace any product found defective, without charge for parts or labor. Repaired or replaced equipment and parts supplied under this warranty shall be covered only by the unexpired portion of the warranty.

Except as expressly set forth in this warranty, CRESTRON makes no other warranties, expressed or implied, nor authorizes any other party to offer any warranty, including any implied warranties of merchantability or fitness for a particular purpose. Any implied warranties that may be imposed by law are limited to the terms of this limited warranty. This warranty statement supersedes all previous warranties.

Trademark Information

All brand names, product names and trademarks are the sole property of their respective owners. Windows is a registered trademark of Microsoft Corporation. Windows95/98/Me/XP/Vista/7 and WindowsNT/2000 are trademarks of Microsoft Corporation.



Crestron Electronics, Inc.
15 Volvo Drive Rockleigh, NJ 07647
Tel: 888.CRESTRON
Fax: 201.767.7576
www.crestron.com

Installation Guide – DOC. 6874B
(2025142)
01.10
Specifications subject to
change without notice.