

Cameo® In-Wall Universal Phase Dimmer, 120 VAC

The Crestron® [CLW-DIMUEX-P](#) is a Cameo® in-wall universal phase dimmer with field replaceable, engravable button caps. The CLW-DIMUEX-P features auto load detection, which allows the dimmer to switch between reverse and forward phase dimming depending on the load connected. iFiNET EX® communication technology brings reliability to the CLW-DIMUEX-P without the need for physical control wiring.



In the Box

- 1 CLW-DIMUEX-P, Cameo® In-Wall Universal Phase Dimmer, 120 VAC

Additional Items

- 2 Plastic, Button, 2 Position
- 4 Plastic, Button, 4 Position
- 2 Screw, 6-32 x 3/4 in., Truss Head, Combo (2009211)

NOTE: Refer to the CLW-DIMUEX-P [product page](#) for a complete list of color and texture variations.



Important Notes

WARNINGS:

- To avoid fire, shock, or death, turn off power at circuit breaker or fuse and test that power is off before wiring!

- New installations should be checked for short circuits prior to installing a CLW-DIMUEX-P dimmer. With power off, close the circuit and restore power. If the lights do not work or a breaker trips, check and correct the wiring or fixture (if necessary). Install the dimmer only when the short is no longer present. The warranty is void if the dimmer is installed and operated with a shorted load.

CAUTION: TO REDUCE THE RISK OF OVERHEATING AND POSSIBLE DAMAGE TO OTHER EQUIPMENT, DO NOT INSTALL TO CONTROL A RECEPTACLE, A MOTOR-OPERATED APPLIANCE, A FLUORESCENT LIGHTING FIXTURE, OR A TRANSFORMER-SUPPLIED APPLIANCE.

ATTENTION: GRADATEURS COMMANDANT UN BALLAST-AFIN DE RÉDUIRE LE RISQUE DE SURCHAUFFE ET LA POSSIBILITÉ D'ENDOMMAGEMENT À D'AUTRES MATÉRIELS, NE PAS INSTALLER POUR COMMANDER UNE PRISE, UN APPAREIL D'ÉCLAIRAGE FLUORESCENT, UN APPAREIL OPÉRÉ DE MOTEUR OU UN APPAREIL ALIMENTÉ PAR UN TRANSFORMATEUR.

NOTES:

- Codes: This product should be installed and used in accordance with appropriate electrical codes and regulations.
- Installation: This product should be installed by a qualified electrician.
- Wiring: Use copper wire only. For supply connections, use wires rated for at least 75° C (167° F).
- Lamp Type: For use with permanently installed LED, incandescent, electronic low voltage, or magnetic low voltage transformer lamp fixtures only.
- Temperature: For use where temperatures are between 32° to 95° F (0° to 35° C).
- Electrical Boxes: Devices mount in standard electrical boxes. For easy installation, use 3 1/2 in. (89 mm) deep electrical boxes. Several devices can be installed in one electrical box (multigang). This requires derating of the dimming device. For a smooth appearance, one-piece multigang faceplates (not supplied) can be installed.

Cameo® In-Wall Universal Phase Dimmer, 120 VAC

- Switches: Mechanical 3- or 4-way switches do not work with CLW-DIMUEX-P dimmers.
- Spacing: If mounting one device above another, leave at least 4 1/2 in. (115 mm) vertical space between them.
- Low Voltage Applications: Operation of a low voltage circuit with all lamps inoperative or removed may result in current flow in excess of normal levels. To avoid transformer overheating and premature transformer failure, Crestron recommends the following:
 - Do not operate low voltage circuits without operative lamps in place.
 - Replace burned-out lamps as quickly as possible.
 - Use transformers that incorporate thermal protection or fuse transformer primary windings to prevent transformer failure due to overcurrent.

Installation

Install the CLW-DIMUEX-P:

1. Turn power off at the circuit breaker.
2. Wire the device as shown in the following diagrams.

NOTES:

- The dimmer and any connected remote dimmer (CLW-SLVU-P) requires a neutral wire connection.
- Up to four CLW-SLVU-P remote dimmers can be used with a CLW-DIMUEX-P dimmer. To wire one or more CLW-SLVU-P remote dimmers, refer to the [CLW-SLVU-P Installation Guide](#) (Doc. 7364).

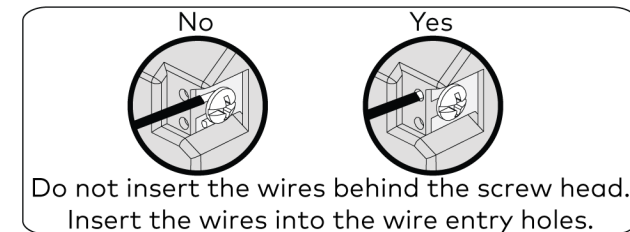
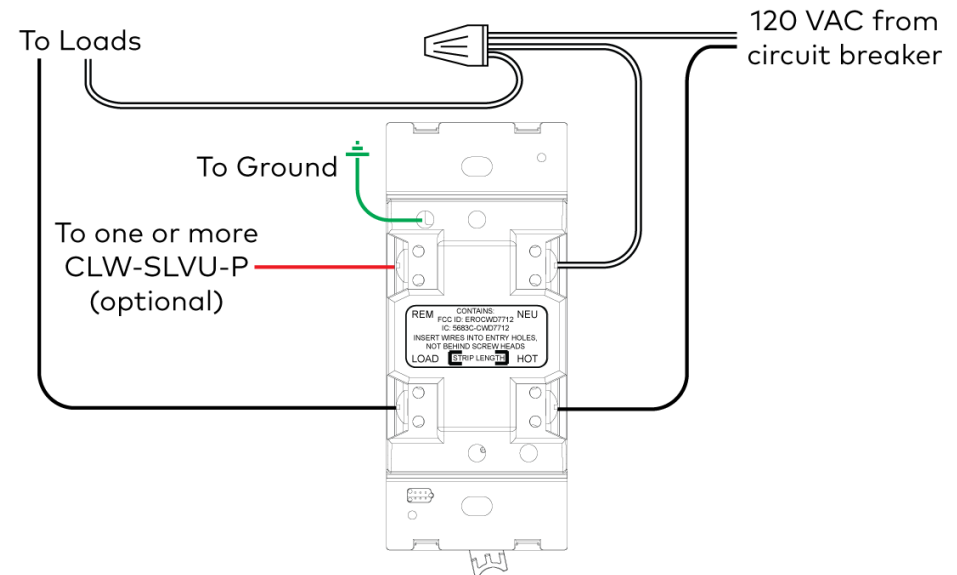

3. Fold the wires into the electrical box. Avoid pinched wires.
4. Fasten the device to the electrical box with the provided screws.
5. Attach the FP-G1 faceplate (not supplied).
6. Ensure all buttons, including the program button and air-gap switch, actuate without sticking.
7. Restore power at the circuit breaker.

Cameo® In-Wall Universal Phase Dimmer, 120 VAC

Multigang Installations

In multigang installations, several devices are grouped horizontally in one electrical box. For a smooth appearance, one-piece multigang faceplates (not supplied) can be installed.

NOTE: When installing into a multigang box, do not fully tighten devices to the box until the faceplate has been aligned.

The load capacity for each device in the electrical box must be derated. Refer to the following diagrams for derating information. The VA ratings are for input power to the transformer. If you do not know the input power requirement of the transformer, use the bulb's wattage rating to determine proper rating.

Derating Information for CLW-DIMUEX-P Dimmers

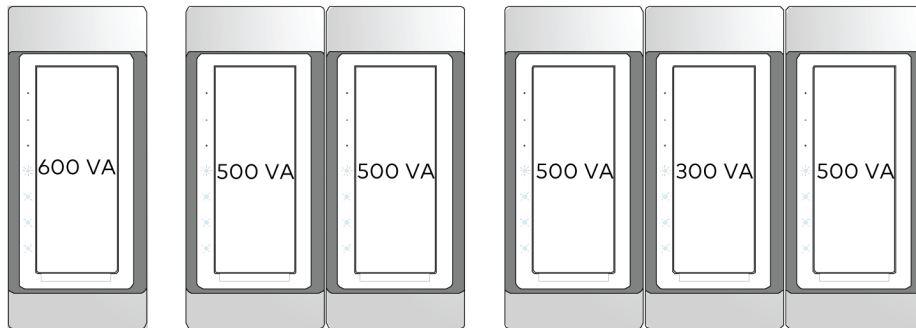

Changing the Button Assemblies

The button assembly can be removed and replaced to accommodate custom button configurations and engravings.

1. Remove the button assembly by squeezing the sides of the bezel near the bezel snaps. When the button assembly is removed, power to the load, the buttons, and the LEDs is removed automatically.

NOTE: When the button assembly is removed, power is still supplied to the HOT terminal.

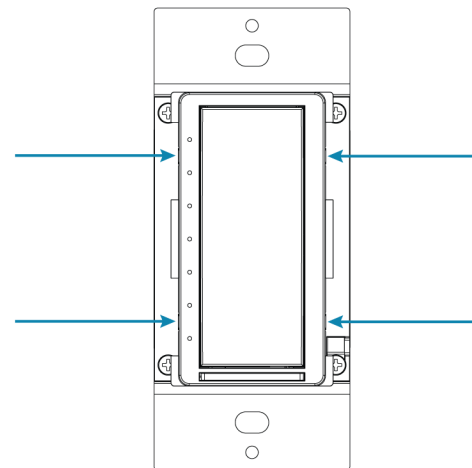

Squeeze at the arrow points and pull to remove the button assembly.

Cameo® In-Wall Universal Phase Dimmer, 120 VAC

2. Remove the button from the front of the button assembly.

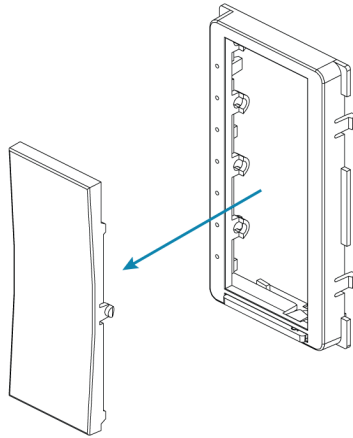

Gently spread the frame apart to remove the button.

3. Insert the new buttons through the front of the bezel and snap them into place. Ensure that the LED strip is on the left side.

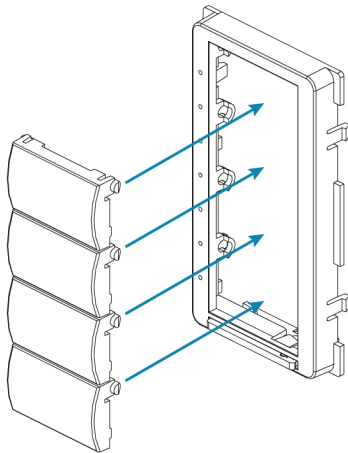

Gently spread the frame apart to insert the buttons.

4. Attach the button assembly to the device. Ensure that the LED strip is on the left side. Power to the load, the buttons, and the LEDs is restored when the button assembly is attached.

NOTE: The air-gap switch must be closed for power to be restored to the load, the buttons, and the LEDs.

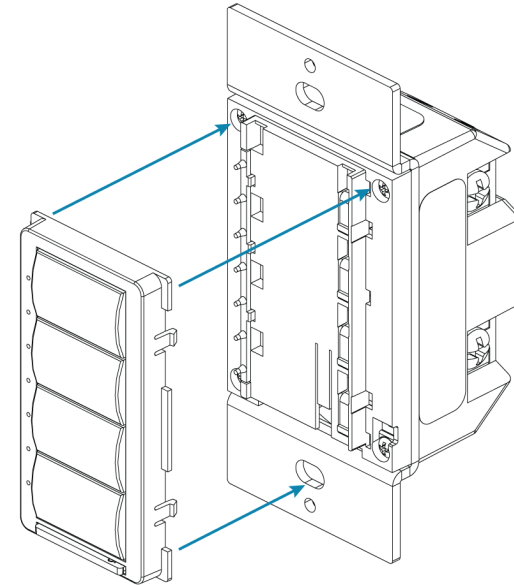

Cameo® In-Wall Universal Phase Dimmer, 120 VAC

- Press and hold the program button. After 5 seconds, the LEDs associated with the old button layout begin to flash. Continue to hold the button.

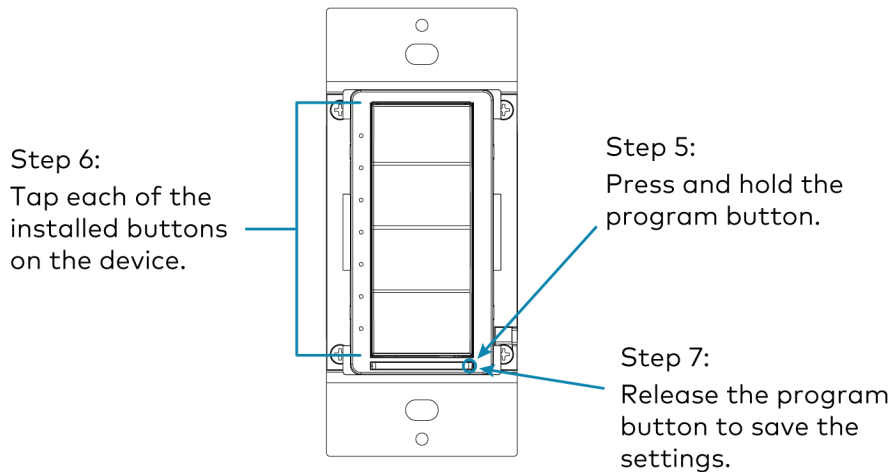

- While holding the program button, press all of the buttons in the new layout. The LED next to the pressed button lights.

NOTE: If the rocker switch is installed, press the top and bottom of the rocker.

- After all of the buttons have been pressed, release the program button to save the settings.

NOTE: Changing the button configuration alters the device's behavior. Refer to [Default Button Functions](#) for details.



Operation

NOTES:

- Before using the CLW-DIMUEX-P, ensure the device is using the latest firmware. Check for the latest firmware for the CLW-DIMUEX-P at www.crestron.com/firmware.
- The device may be warm to the touch during operation. This is normal.

Basic Operation

The operations described in this guide assume the CLW-DIMUEX-P is operating in Local mode (without the use of a control system). The device can also operate in Remote mode, in which button behavior is dictated entirely by the control system program. The CLW-DIMUEX-P is shipped with a rocker button already installed. In this configuration, the unit functions as described below.

LEDs indicate the load level. When all loads are off, the top LED remains dimly lit to act as a night light.

In Switch mode, the top LED indicates the On/Off status only. All other LEDs are off.

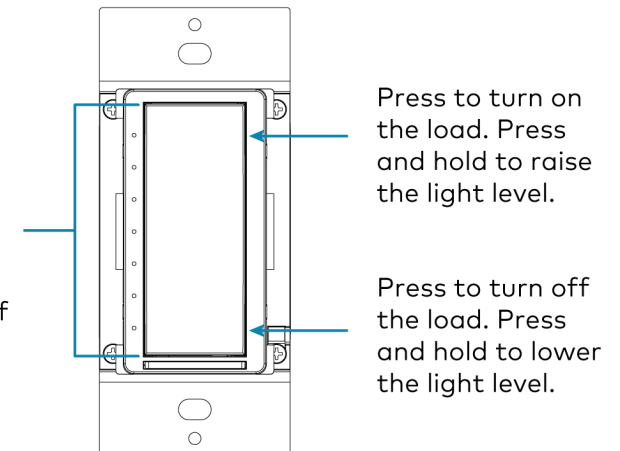

Cameo® In-Wall Universal Phase Dimmer, 120 VAC

Disconnecting the Power

Power to the connected loads, the device buttons, and the LEDs can be disconnected by pushing on the air-gap switch.

NOTES:

- When the air-gap switch is open, power is still supplied to the HOT terminal of the device.
- Power to the load is automatically disconnected when the button assembly is removed. For instructions on removing the button assembly, refer to [In the Box](#).

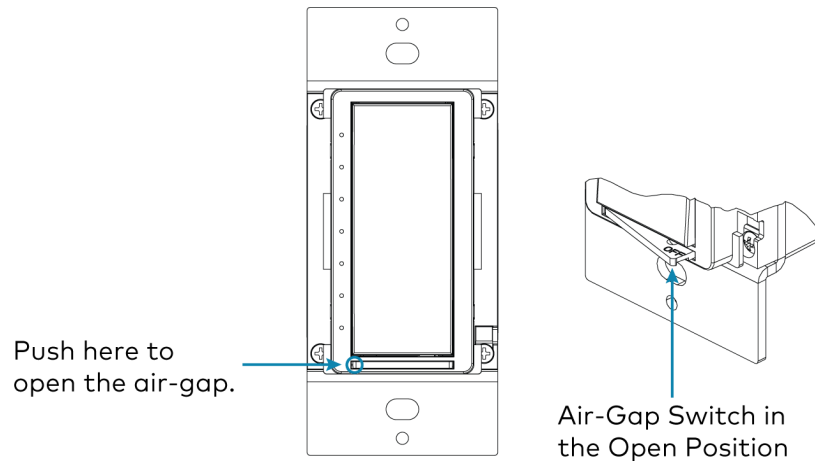

Setting Preset Levels

The CLW-DIMUEX-P can recall and store up to three presets depending on the installed button configuration. The device has default preset levels.

To set new preset levels:

1. Adjust the light level to the desired level.
2. Tap the program button to enter Programming mode as shown below. The LEDs of buttons that are capable of storing a preset will flash.

NOTE: Programming mode is disabled when the load is off.

3. Press and hold the desired preset button until the LED flashes (approximately two seconds). Release the button to store the new level.

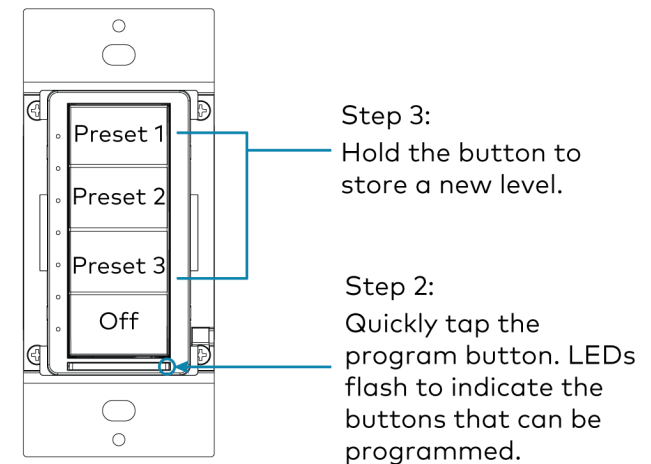

NOTE:

- If a button is not pressed, the device exits Programming mode after approximately five seconds.
- A delayed off can be added via control system programming.

Cameo® In-Wall Universal Phase Dimmer, 120 VAC

Default Button Functions

The figures below illustrate the default functions available for each physical button configuration and tap or hold actuation sequence.

Single Button Press

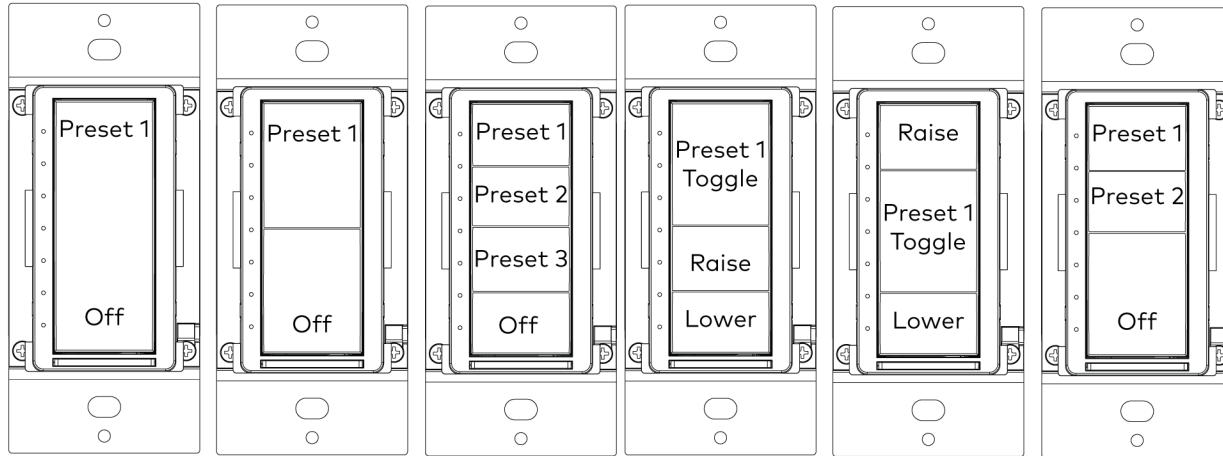

Double Button Press (Press twice within 1/2 second)

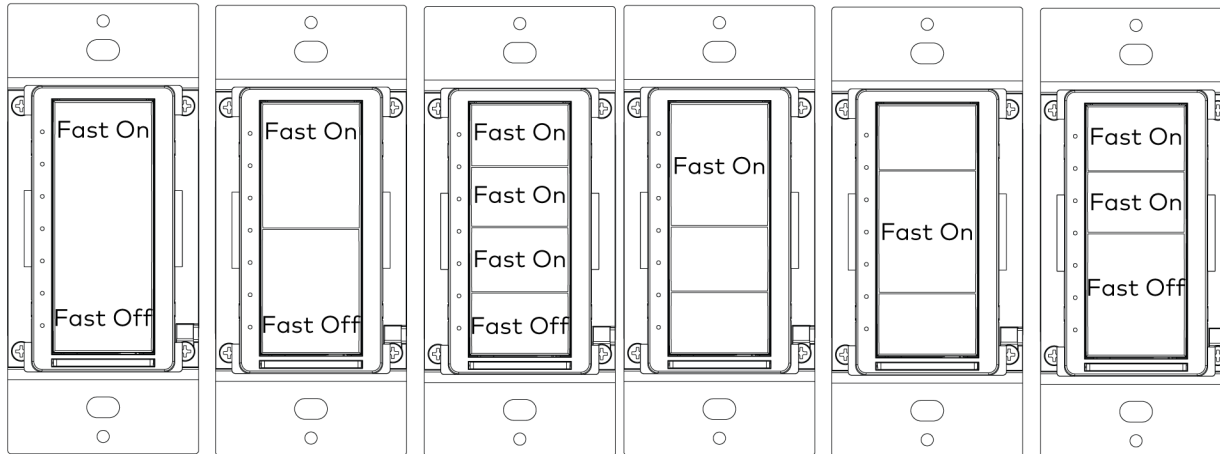

Cameo® In-Wall Universal Phase Dimmer, 120 VAC

Single Button Press and Hold (Hold for more than 1/2 second)

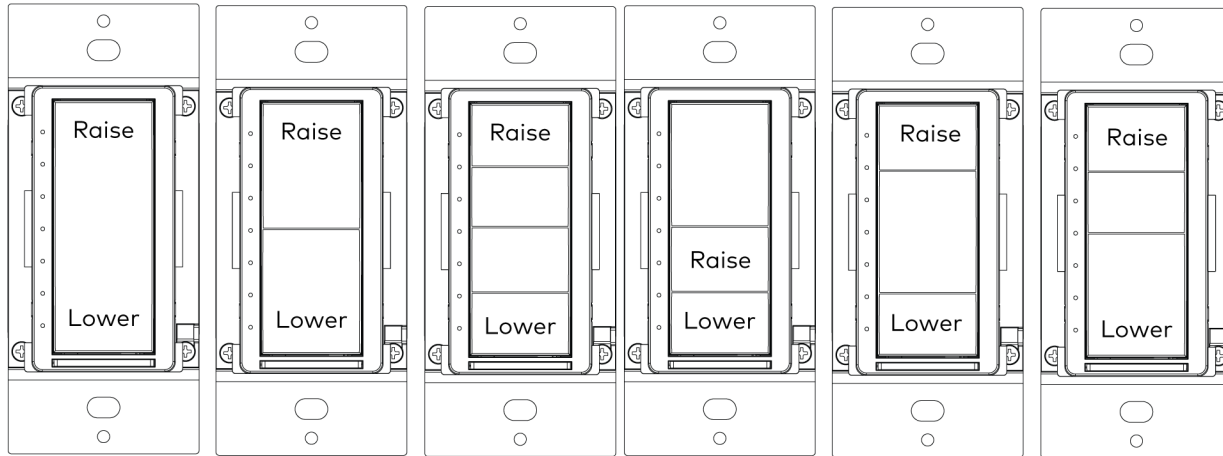

Cameo® In-Wall Universal Phase Dimmer, 120 VAC

Master and Slave Operation

The CLW-DIMUEX-P supports multipoint dimming when used in conjunction with a CLW-SLVU-P slave dimmer. Multipoint dimming is similar to conventional 3- or 4-way switching, allowing dimming control of a single load from multiple locations in the room.

For more information on master and slave operation, refer to the [CLW-SLVU-P Installation Guide](#) (Doc. 7364).

Changing the Dim Mode

By default, the device is set to Auto Phase Dimming mode, which allows the device to automatically toggle between forward and reverse phase dimming based on the connected load. The device can be set to Auto Phase Dimming mode or Forward Phase Dimming mode manually.

To set the dimming mode:

1. Open the air-gap switch as described in [Master and Slave Operation](#).
2. While power is off, set the dimming mode:
 - **Auto Phase Dimming Mode:** Press and hold the top button cap.
 - **Forward Phase Dimming Mode:** Press and hold the bottom button cap.
3. While holding the appropriate button, close the air-gap to restore power to the connected load, the device buttons, and the LEDs.
4. After all LEDs have flashed once, release the button cap.

NOTE: If the dimming mode is set in the control system program, the LEDs will flash five times and the new mode will not be set. To modify the parameter, change the setting in the control system program to "Local Settings" and retry the operation.

5. After the released button's LED flashes once, the device will boot-up in the selected dimming mode.



Wireless Communications

The device connects to the Crestron network via the infiNET EX communications protocol. Use the procedures outlined below to join or leave an infiNET EX network and to verify communications between the device and the control system.

Joining an infiNET EX Network

Before a device can be used in a lighting system, it must first join an infiNET EX network by being acquired by an infiNET EX gateway. The CLW-DIMUEX-P is compatible with the CEN-GWEXER wireless gateway and the MC4-R media room controller.

NOTE: A device can be acquired by only one gateway.

1. Put the infiNET EX gateway into Acquire mode from the unit itself or from Crestron Toolbox™ software, as described in either the [CEN-GWEXER and CEN-GWEXER-PWE Quick Start](#) (Doc. 7723) or the [MC4-R and MC4-R-I Quick Start](#) (Doc. 8545).

NOTE: In an environment where multiple gateways are installed, only one gateway should be in Acquire mode at any time.

Cameo® In-Wall Universal Phase Dimmer, 120 VAC

2. Place the device into Acquire mode.
 - a. Tap the top button three times, and then press and hold it down (tap-tap-tap-press+hold) until the top LED on the device flashes once (this can take up to 10 seconds if the device has been previously acquired to a gateway).
 - b. Release the button to start the acquire process. The top button's LED flashes slowly to show that the device is actively scanning the infiNET EX network.
 - The top button's LED turns on for 5 seconds to show that the device has been successfully acquired to the infiNET EX network.
 - The top button's LED flashes quickly to indicate that the device was not successfully acquired by the infiNET EX network. Tap the top button to acknowledge failure to acquire the infiNET EX network. Before attempting the acquire process again, ensure one of the following:
 - The gateway is in Acquire mode and within range.
 - A non-battery powered infiNET EX device is in Acquire mode on the same gateway.
3. Once all devices have been acquired, take the gateway out of Acquire mode. Refer to the gateway's manual for details.

Leaving an infiNET EX Network

To leave an infiNET EX network, put the device into Acquire mode, as described in [Joining an infiNET EX Network](#), when no gateway is in Acquire mode.

Verifying Communications Status

To check the communications status of the device, tap the top button three times and then press and hold it down (tap-tap-tap-press+hold) for up to 2 seconds. The top button's LED flashes to indicate the communications status. Refer to the following table for details.

LED	Communications Status
Turns on for 5 seconds	The device is communicating with the control system.
Flashes three times	The device is communicating with the gateway, but the gateway is not communicating with the control system.
Flashes twice	The device was previously joined to the network but is not communicating with the gateway.
Flashes once	The device is not joined to the network.



Troubleshooting

The device displays error codes using the device LEDs. All LEDs flash a pattern to indicate the error on that output. For example, a 1-2 error flashes all LEDs one time, pauses for 1 second, flashes two times, pauses for 2 seconds, and then repeats for 90 seconds (except where otherwise noted). Refer to the following table for possible corrections.

Error Code	Fault Name	Fault Description
2-1	Over Current	A short circuit has been detected. Verify that there are no shorts in the wiring and that the total load output matches the proper ganged ratings.
2-2	Shorted FET	A flowing current is detected when an FET should be off. The load will power to 100%. This error code is permanent until the device is power cycled. Disconnect the load and contact Crestron Technical Support.
2-3	Over Temperature	The dimmer has overheated and shut down due to an excessive load. Verify that the total load matches the proper ganged rating. The dimmer resumes normal operation after cooling.

Cameo® In-Wall Universal Phase Dimmer, 120 VAC

Error Code	Fault Name	Fault Description
2-4	Over Voltage	High voltage spikes have been detected and output has been shut down. If a magnetic load is connected, verify that the dimming phase has been set to Forward Phase Dimming mode.
2-5	Overload	A load is detected beyond the allowable load rating. This error code will cause the device to shut down. Verify that the total load output matches the proper ganged rating.
3-1	Zero Cross Fault	The dimmer is unable to lock onto the AC line. If the unit is powered by a generator, verify that the generator output is 50/60 Hz and stable.

The following table provides corrective action for possible trouble situations. If further assistance is required, please contact a Crestron customer service representative.

Trouble	Probable Cause(s)	Corrective Action
The dimmer does not function.	The dimmer is not receiving power.	Verify that the power connections are correct and that the circuit breaker is closed.
	The load is not operational (e.g., lamps are burned out)	Verify that the load is operational and that the air-gap switch is closed.
	The dimmer is in Remote mode.	Check the SIMPL program to verify the operating mode.
	The air-gap is open.	Ensure that the air-gap is closed.
	The dimmer has overheated.	Verify that the dimmer is loaded properly for the ganged configuration.
	The neutral wire is not connected to the dimmer.	Connect a neutral wire to the dimmer.

Trouble	Probable Cause(s)	Corrective Action
The load does not dim to a low level or flickers when dimmed.	The loads connected may be better suited to an alternate dimming mode.	Switch the dimmer to an alternate dimming mode. Contact Crestron Technical support.
The dimmer does not acquire after several attempts.	The gateway is not supported with this dimmer.	Ensure that either a CEN-GWEXER or an MC4-R gateway is in use.
	Device requires reboot.	Power cycle the dimmer and reattempt the acquire process. If the acquire is still unsuccessful, contact Crestron Technical Support.

Cameo® In-Wall Universal Phase Dimmer, 120 VAC



Visit the Product Page

Scan the QR code to visit the product page.



www.crestron.com/model/6511056

Additional Information

Original Instructions

The U.S. English version of this document is the original instructions. All other languages are a translation of the original instructions.

Crestron product development software is licensed to Crestron dealers and Crestron Service Providers (CSPs) under a limited nonexclusive, nontransferable Software Development Tools License Agreement. Crestron product operating system software is licensed to Crestron dealers, CSPs, and end-users under a separate End-User License Agreement. Both of these Agreements can be found on the Crestron website at www.crestron.com/legal/software_license_agreement.

The product warranty can be found at www.crestron.com/warranty.

The specific patents that cover Crestron products are listed at www.crestron.com/legal/patents.

Certain Crestron products contain open source software. For specific information, visit www.crestron.com/opensource.

Crestron, the Crestron logo, Cameo, Crestron Toolbox, and infiNET EX are either trademarks or registered trademarks of Crestron Electronics, Inc. in the United States and/or other countries. Other trademarks, registered trademarks, and trade names may be used in this document to refer to either the entities claiming the marks and names or their products. Crestron disclaims any proprietary interest in the marks and names of others. Crestron is not responsible for errors in typography or photography.

©2020 Crestron Electronics, Inc.

Doc ID 8482A

07/16/20