

# Crestron **TMK-3100L & WMKT-3100L**

## Trim Ring Mount Kits

---

## Installation Guide



This document was prepared and written by the Technical Documentation department at:



Crestron Electronics, Inc.

15 Volvo Drive

Rockleigh, NJ 07647

1-888-CRESTRON

# Trim Ring Mount Kits: TMK-3100L & WMKT-3100L

---

## Description

Trim Ring Mount Kits are the preferred method of mounting the Crestron Isys<sup>®</sup> TPS-3100L series of lectern/wall-mounted video touchpanels when a finished appearance within a neatly trimmed cutout is required. This application is perfect for wallpapering.

There are two Trim Ring Mount Kits. The TMK-3100L is a pre-construction accessory. Pre-construction refers to framed walls prior to hanging drywall. This accessory must be used with either the Pre-Construction Mount Kit (PMK-3100L) or Back Box Kit (BB-3100L).

The WMKT-3100L is a post-construction kit. Post-construction refers to framed walls with drywall hung. This accessory is designed with a mounting plate so that it can be placed anywhere on a wall without the support from a stud. The mounting plate is also ideal for installing the touchpanel in a lectern.

---

**NOTE:** If necessary, consult the latest revision of the TPS-3100L Operations Guide (Doc. 6291) for a complete list of mounting options.

---

---

## Supplied Hardware

The TMK-3100L consists of a metal trim ring that attaches to the PMK-3100L or BB-3100L. The WMKT-3100L consists of the trim ring found in the TMK-3100L as well as a mounting plate. The mounting plate is the part that provides the necessary support for post-construction applications.

*Supplied Hardware of the TMK-3100L and WMKT-3100L*

DESCRIPTION	PART NUMBER	QUANTITY
Metal Plate, Mounting (WMKT-3100L only)	2010620	1
Metal Trim Ring	2010619	1

The dimensions of the TMK-3100L/WMKT-3100L are shown below.

**Dimensional Drawing**

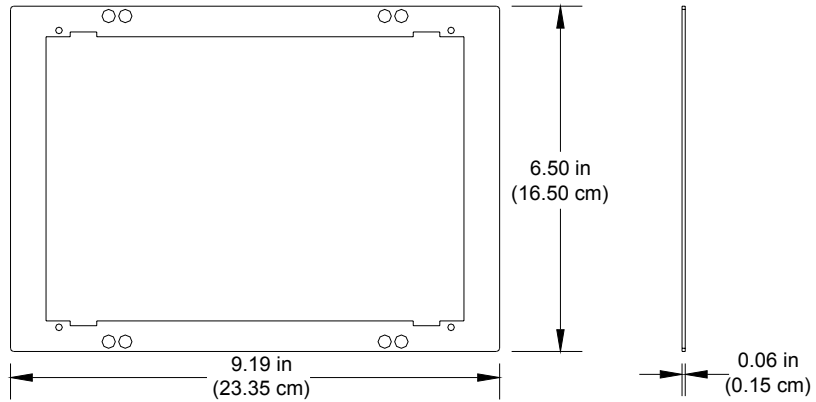

**MOUNTING PLATE (WMKT-3100L ONLY)**

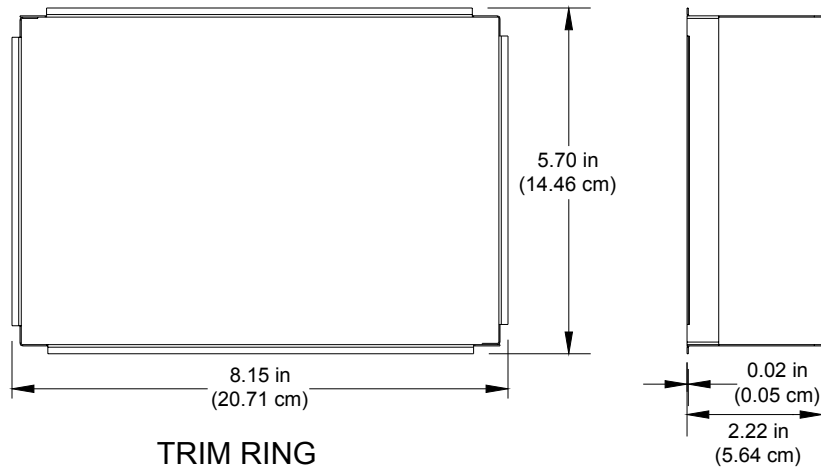

**TRIM RING**

**Drywall Cutout Dimensions**

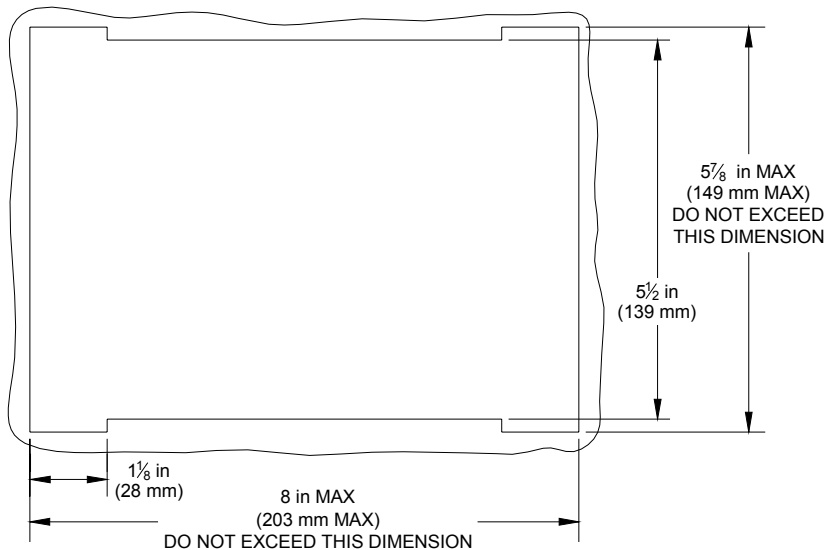

---

## Installation

This section provides an installation procedure for each Trim Ring Mount Kit. The procedure for the TMK-3100L starts below and the “WMKT-3100L Procedure” starts on page 4.

### TMK-3100L Procedure

The procedure in this section provides the necessary steps for the assembly of the TMK-3100L to either the PMK-3100L or BB-3100L. It is assumed that the PMK-3100L or BB-3100L has been secured to the stud according to the procedures in the latest revisions of their respective Installation Guides (Doc. 6297 and Doc. 6298, respectively). Also, it is assumed that drywall is in place and a rectangular cutout for the touchpanel is made in the drywall (refer to the Drywall Cutout dimensions on the previous page for cutout dimensions).

Complete the steps in the order provided. The only tool required and not supplied is a level.

---

**NOTE:** When installing into the PMK-3100L, verify that the 18 AWG bus wire securing the cables for the touchpanel remains attached.

---

1. Verify that the rectangular cutout in the drywall is as level as possible.
2. Insert the symmetrical trim ring into the opening, as shown in the following diagram.

#### *Insert Trim Ring into Opening*

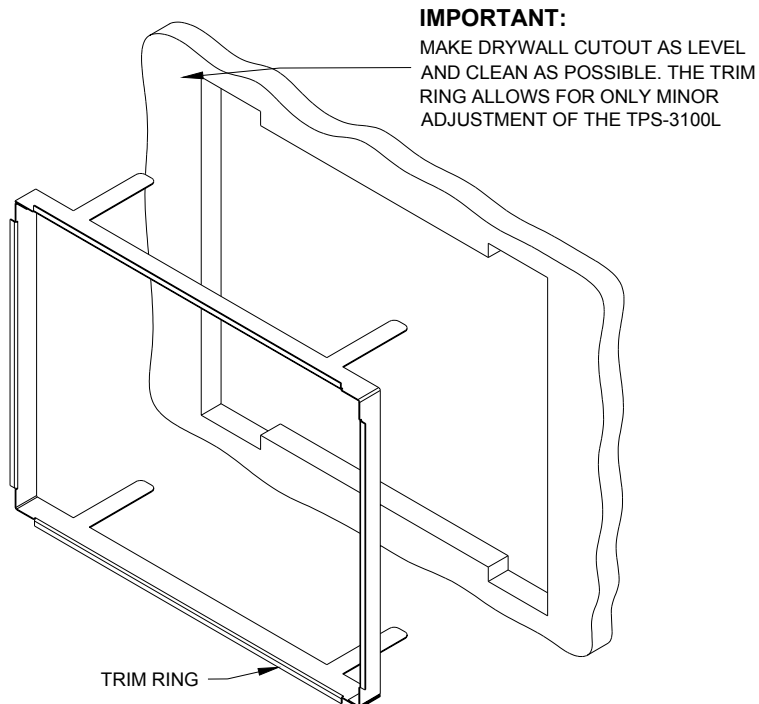

---

**NOTE:** The required PMK-3100L or BB-3100L is not shown.

---

3. When the trim ring is in position, bend the top two flanges of the ring upward and the bottom two flanges downward.
  - If mounting into the PMK-3100L, bend the flanges approximately 90 degrees.
  - If mounting into the BB-3100L, bend the flanges back as far as they can go.
4. Run the necessary cables for the touchpanel and secure them behind the drywall.
5. The TPS-3100L can be installed using the four tapped holes in the PMK-3100L or BB-3100L. Refer to the latest revision of the TPS-3100L Operations Guide (Doc. 6291) for details.

### **WMKT-3100L Procedure**

The procedure in this section provides the necessary steps for installation of the WMKT-3100L into a wall. Complete the steps in the order provided. The only tools or materials required and not supplied are a drywall saw or equivalent and a level.

1. Locate an area on the wall that is free of miscellaneous wiring and studs.
2. Make a small hole near the middle of the designated site; verify that the location is suitable.

---

**NOTE:** Make the cutout as level and smooth as possible. The mounting plate allows for only minor leveling adjustments. If a larger cutout is accidentally made, consider purchasing the Crestron Mud Mount Kit, MMK-3100L. It and the mounting plate supplied with the WMKT-3100L provide a cost-effective means of correction. Essentially, The combination of these two kits makes up the Crestron Mud Mount Kit for the Wall, WMKM-3100L. Simply follow the “WMKM-3100L Procedure” in the latest revision of the Mud Mount Kits Installation Guide (Doc. 6296).

---

3. Use the drywall saw or equivalent to produce a level, rectangular cutout in the drywall (refer to the Drywall Cutout dimensions on page 2 for cutout dimensions.).
4. Insert the symmetrical trim ring into the opening, as shown in the following diagram.

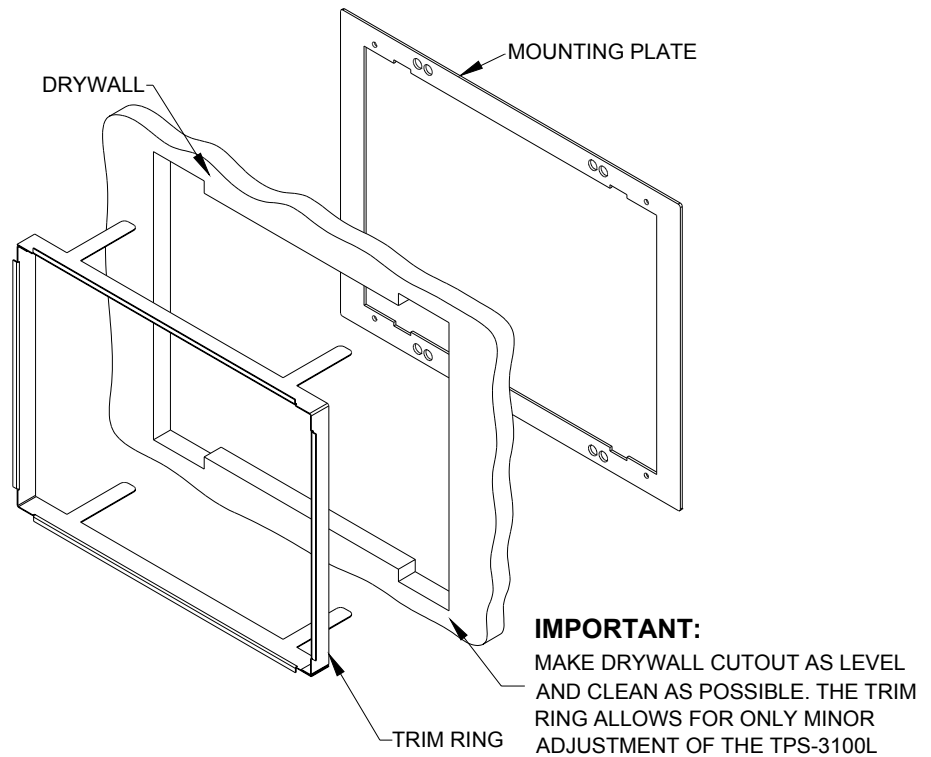
*Insert the Trim Ring into the Opening*

5. Carefully pass the mounting plate through the opening and rest it against the interior surface of the drywall.
6. When the mounting plate is in position, bend the top two flanges of the trim ring upward (approximately 90 degrees) and the bottom two flanges downward (approximately 90 degrees). Refer to the following diagram.

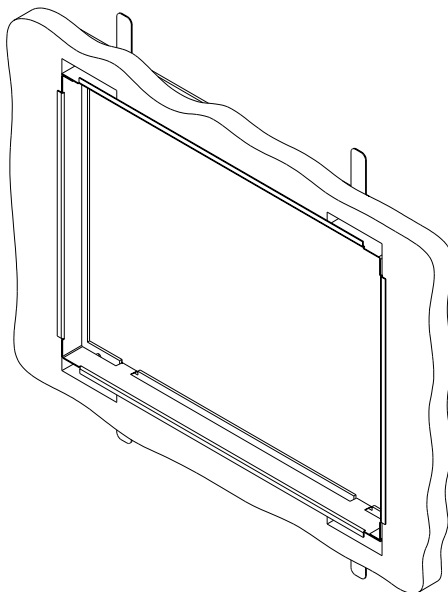
*Bend Flanges*

---

**NOTE:** The mounting plate will have slight play; this is normal. It allows for minor adjustments to the TPS-3100L during installation.

---

7. Run the necessary cables for the touchpanel and secure them behind the drywall.
8. The TPS-3100L can be installed using the four tapped holes in the mounting plate. Refer to the latest revision of the TPS-3100L Operations Guide (Doc. 6291) for details.



---

## Further Inquiries

If after reviewing this Installation Guide, you cannot locate specific information or have questions, please take advantage of Crestron's award winning customer service team by calling:

- In the US and Canada, call Crestron's corporate headquarters at 1-888-CRESTRON [1-888-273-7876].
- In Europe, call Crestron International at +32-15-50-99-50.
- In Asia, call Crestron Asia at +852-2341-2016.
- In Latin America, call Crestron Latin America at +5255-5093-2160.
- In Australia and New Zealand, call Crestron Control Solutions at +61-2-9737-8203.

You can also log onto the online help section of the Crestron website ([www.crestron.com](http://www.crestron.com)) to ask questions about Crestron products. First-time users will need to establish a user account to fully benefit from all available features.

As of the date of manufacture, the TMK-3100L and WMKT-3100L have been tested and found to comply with specifications for CE marking.



---

## Future Updates

As Crestron improves functions, adds new features, and extends the capabilities of the TMK-3100L or WMKT-3100L, additional information may be made available as manual updates. These updates are solely electronic and serve as intermediary supplements prior to the release of a complete technical documentation revision.

Check the Crestron website ([www.crestron.com](http://www.crestron.com)) periodically for manual update availability and relevance. Updates are available from the Download | Product Manuals section and are identified as an “Addendum” in the Download column.

---

## Return and Warranty Policies

### Merchandise Returns / Repair Service

1. No merchandise may be returned for credit, exchange, or service without prior authorization from CRESTRON. To obtain warranty service for CRESTRON products, contact the factory and request an RMA (Return Merchandise Authorization) number. Enclose a note specifying the nature of the problem, name and phone number of contact person, RMA number, and return address.
2. Products may be returned for credit, exchange, or service with a CRESTRON Return Merchandise Authorization (RMA) number. Authorized returns must be shipped freight prepaid to CRESTRON, 6 Volvo Drive, Rockleigh, N.J., or its authorized subsidiaries, with RMA number clearly marked on the outside of all cartons. Shipments arriving freight collect or without an RMA number shall be subject to refusal. CRESTRON reserves the right in its sole and absolute discretion to charge a 15% restocking fee, plus shipping costs, on any products returned with an RMA.
3. Return freight charges following repair of items under warranty shall be paid by CRESTRON, shipping by standard ground carrier. In the event repairs are found to be non-warranty, return freight costs shall be paid by the purchaser.

### CRESTRON Limited Warranty

CRESTRON ELECTRONICS, Inc. warrants its products to be free from manufacturing defects in materials and workmanship under normal use for a period of three (3) years from the date of purchase from CRESTRON, with the following exceptions: disk drives and any other moving or rotating mechanical parts, pan/tilt heads and power supplies are covered for a period of one (1) year; touchscreen display and overlay components are covered for 90 days; batteries and incandescent lamps are not covered.

This warranty extends to products purchased directly from CRESTRON or an authorized CRESTRON dealer. Purchasers should inquire of the dealer regarding the nature and extent of the dealer's warranty, if any.

CRESTRON shall not be liable to honor the terms of this warranty if the product has been used in any application other than that for which it was intended, or if it has been subjected to misuse, accidental damage, modification, or improper installation procedures. Furthermore, this warranty does not cover any product that has had the serial number altered, defaced, or removed.

This warranty shall be the sole and exclusive remedy to the original purchaser. In no event shall CRESTRON be liable for incidental or consequential damages of any kind (property or economic damages inclusive) arising from the sale or use of this equipment. CRESTRON is not liable for any claim made by a third party or made by the purchaser for a third party.

CRESTRON shall, at its option, repair or replace any product found defective, without charge for parts or labor. Repaired or replaced equipment and parts supplied under this warranty shall be covered only by the unexpired portion of the warranty.

Except as expressly set forth in this warranty, CRESTRON makes no other warranties, expressed or implied, nor authorizes any other party to offer any warranty, including any implied warranties of merchantability or fitness for a particular purpose. Any implied warranties that may be imposed by law are limited to the terms of this limited warranty. This warranty statement supercedes all previous warranties.

#### Trademark Information

*All brand names, product names, and trademarks are the sole property of their respective owners. Windows is a registered trademark of Microsoft Corporation. Windows95/98/Me/XP and WindowsNT/2000 are trademarks of Microsoft Corporation.*

This page intentionally left blank.



---

**Crestron Electronics, Inc.**  
15 Volvo Drive Rockleigh, NJ 07647  
Tel: 888.CRESTRON  
Fax: 201.767.7576  
[www.crestron.com](http://www.crestron.com)

**Installation Guide – DOC. 6295**  
**09.04**

Specifications subject to  
change without notice.