

Vertical Networked Power Controller & Conditioner with Surge Protection and Metering

The PC-350V-12 and PC-350V-18 are vertical rack-mountable power controllers. They provide 120VAC power distribution, switching, surge protection, noise filtering, and energy monitoring for Crestron® control systems, AV systems, computers, and other equipment.



In the Box

Qty.	Description
1	PC-350V-12 or PC-350V-18
Additional Items	
1	Power cord, 9.8 ft (3 m)
2	Mounting brackets
4	Mounting screws
Spare parts	
1	Keyhole mount



Install the Device

Rack Mounting Safety Precautions

Elevated Operating Ambient Temperature: If installed in a closed or multi-unit rack assembly, the operating ambient temperature of the rack environment may be greater than room ambient temperature. Therefore, consideration should be given to installing the equipment in an environment compatible with the maximum ambient temperature (T_{ma}) specified by the manufacturer.

Reduced Airflow: Installation of the equipment in a rack should be such that the amount of airflow required for safe operation of the equipment is not compromised.

Mechanical Loading: Mounting of the equipment in the rack should be such that a hazardous condition is not achieved due to uneven mechanical loading.

Circuit Overloading: Consideration should be given to the connection of the equipment to the supply circuit and the effect that overloading of the circuits might have on overcurrent protection and supply wiring. Appropriate consideration of equipment nameplate ratings should be used when addressing this concern.

Reliable Earthing: Reliable earthing of rack-mounted equipment should be maintained. Particular attention should be given to supply connections other than direct connections to the branch circuit (e.g., use of power strips).

NOTE: If connected to a device that removes the neutral to earth bonding, such as a UPS (Uninterrupted Power Supply), disable the Full Fault Protection setting in the Web UI to prevent a false fault detection. Disabling the Full Fault Protection setting prevents the device from detecting miswire conditions and the ability to detect if some of the device's surge protection has been compromised. Disabling the Full Fault Protection setting will void the Connected

Vertical Networked Power Controller & Conditioner with Surge Protection and Metering

Equipment Protection Warranty of the PC-350V. Your UPS may provide a Connected Equipment Protection Warranty in this instance.

WARNING: If using a shielded Ethernet cable, exercise additional caution in verifying the inlet ground connection is established. The power controller may see a shielded Ethernet cable as a ground connection without an established life safety ground connection available at the inlet.

Use one of the following procedures to mount the power controller into a rack:

- [Toolless Mounting](#)

NOTE: For toolless mounting, the rack must have keyhole slots on the rack frame or accessory channels with keyhole slots.

- [Mounting the Device With Keyhole Mounts](#)
- [Mounting the Device Without Keyhole Mounts](#)

NOTE: Unless otherwise indicated in this guide, the installation procedure is the same for PC-350V-12 and PC-350V-18.

Toolless Mounting

1. Align the keyhole mounts on the rear of the device to the keyhole slots on the rack frame or the accessory channel.
2. Insert and slide the device down to lock firmly into position.

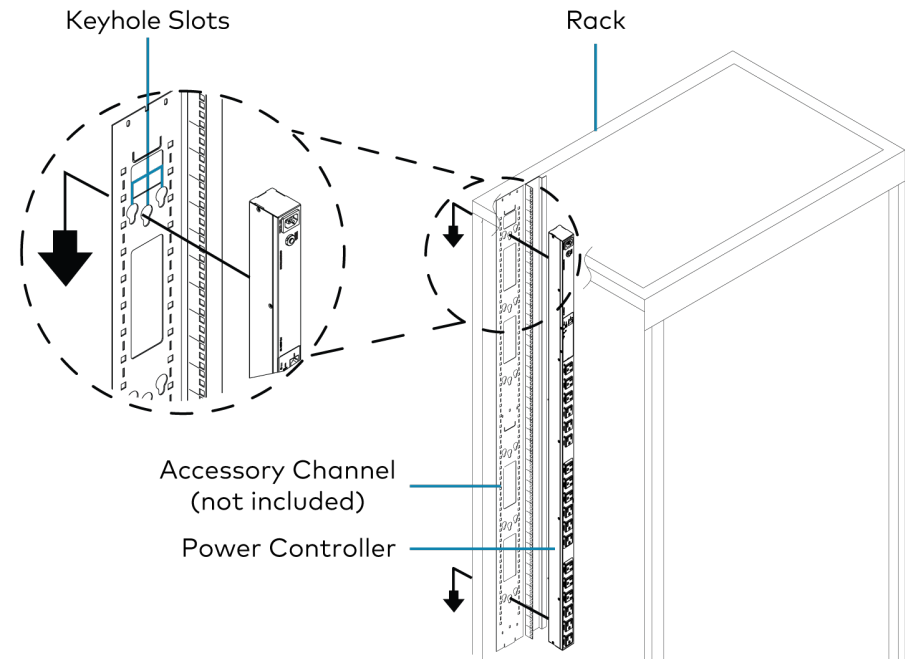

Vertical Networked Power Controller & Conditioner with Surge Protection and Metering

Mounting the Device With Keyhole Mounts

1. Use the rack mounting screws (not included) and washers (not included) to attach the two included brackets to the rack angle.

When attaching the brackets to the rack angle, ensure that the distance between the bracket keyholes is aligned with the distance between keyhole mounts on the rear of the device. As shown below, this distance for PC-350V-12 and PC-350V-18 is 24.49 in. (622 mm) and 36.73 in. (933 mm), respectively.

Distance between keyhole mounts for PC-350V-12 and PC-350V-18

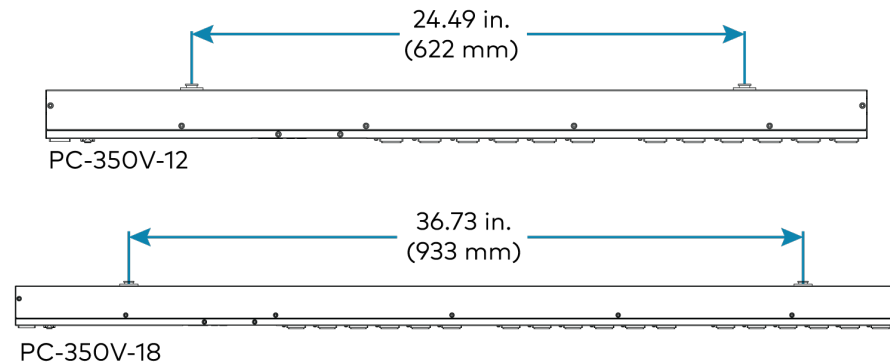

Brackets can be attached to the rack angle using one of the following three methods. Follow the method that is best for your rack deployment to secure the device.

2. Align the keyhole mounts on the rear of the device to the keyhole slots on the mounting brackets.
3. Insert and slide the device down to lock firmly into position.

Vertical Networked Power Controller & Conditioner with Surge Protection and Metering

Method 1

Attaching brackets to the rack angle

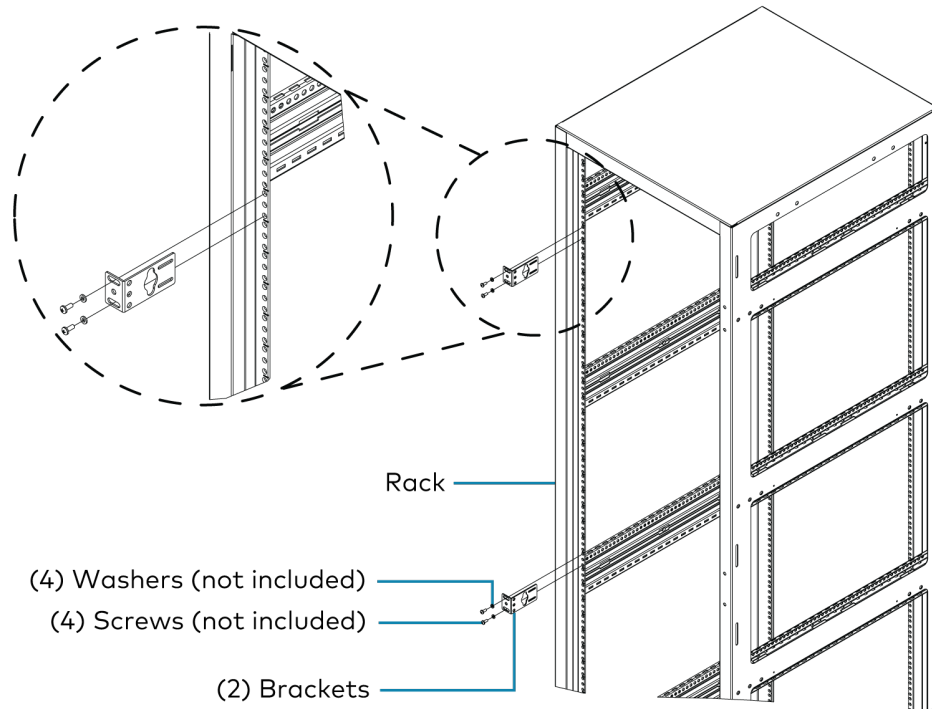

Mounting the device onto the brackets

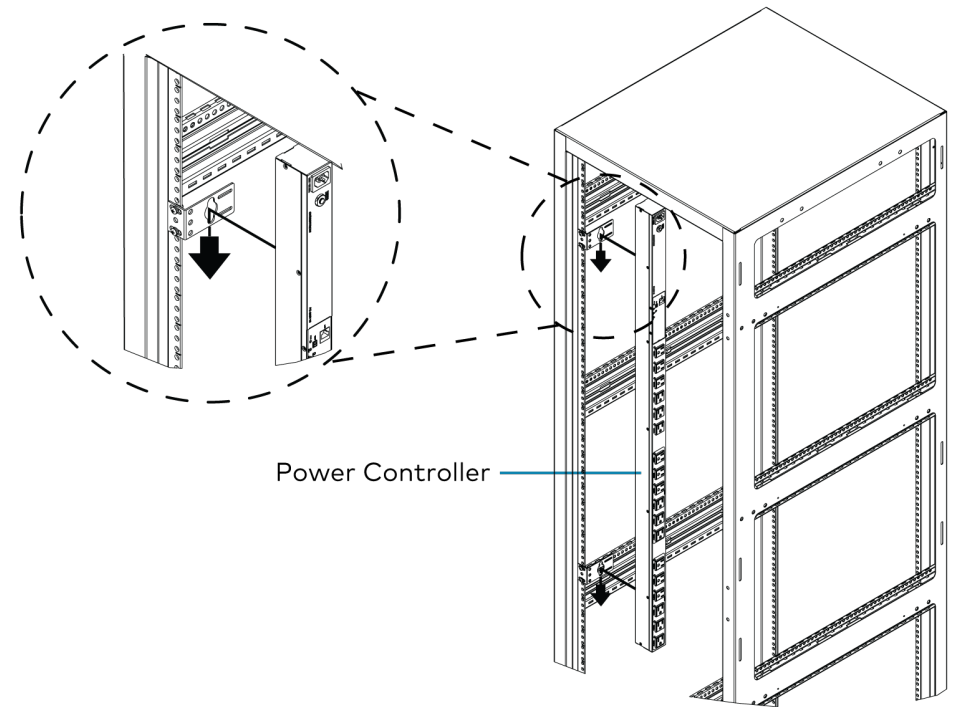

Vertical Networked Power Controller & Conditioner with Surge Protection and Metering

Method 2

Attaching brackets to the rack angle

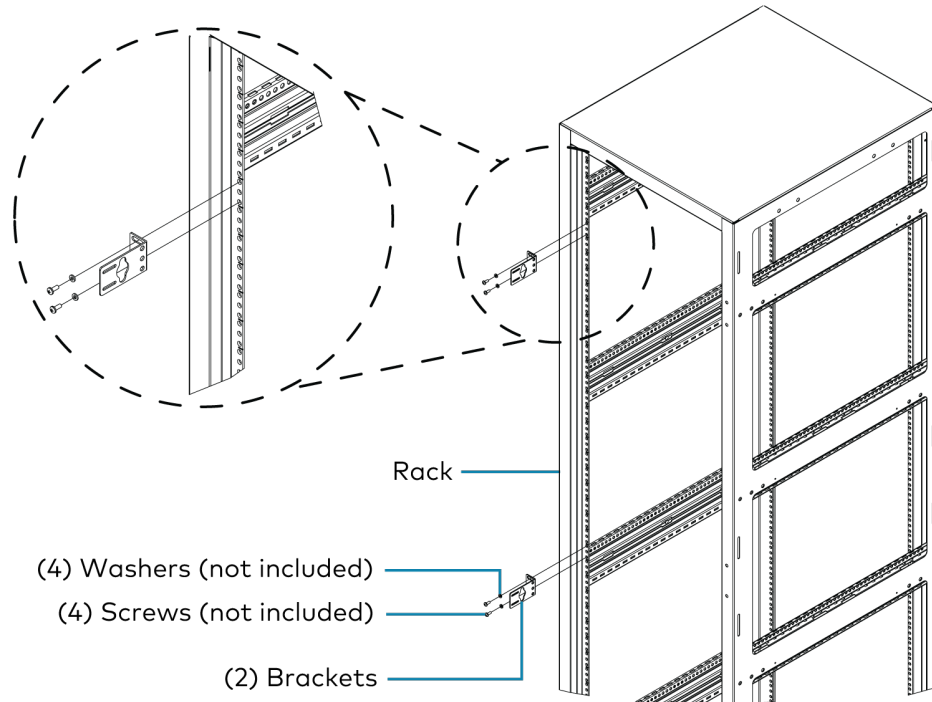

Mounting the device onto the brackets

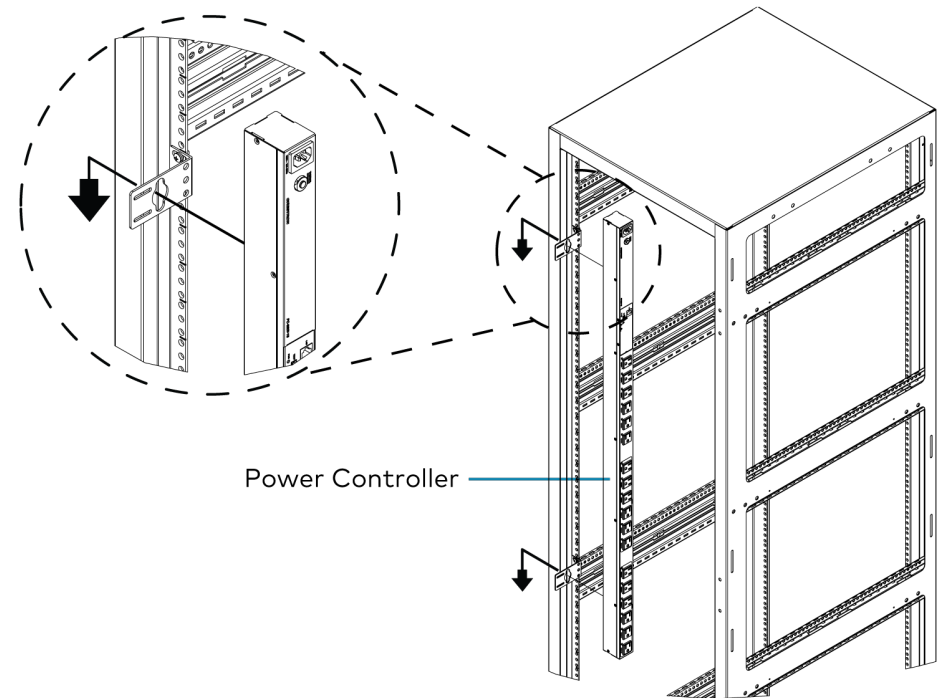

Vertical Networked Power Controller & Conditioner with Surge Protection and Metering

Method 3

Attaching brackets to the rack angle

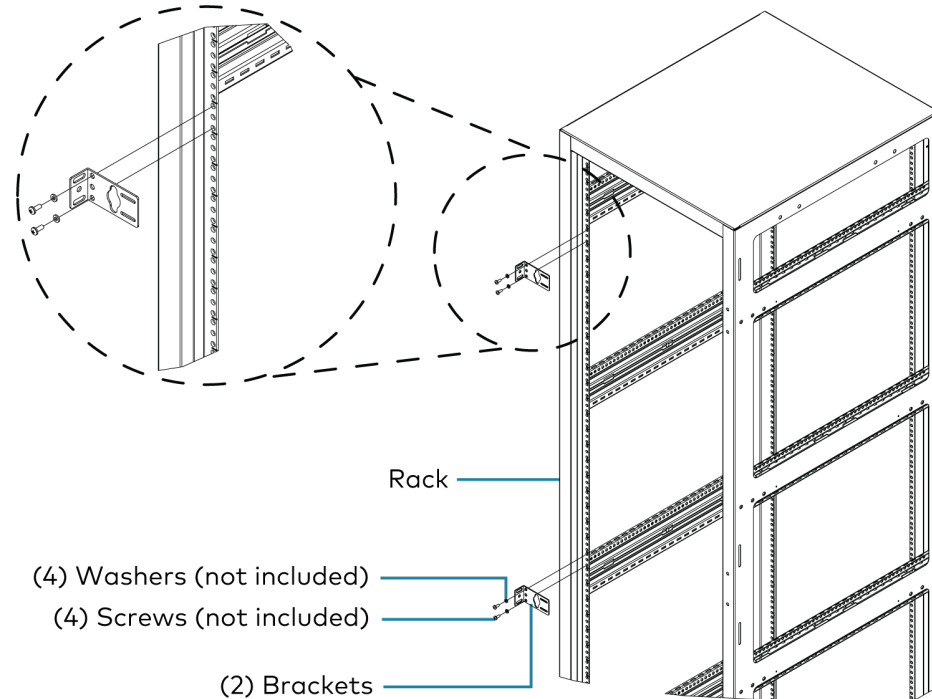

Mounting the device onto the brackets

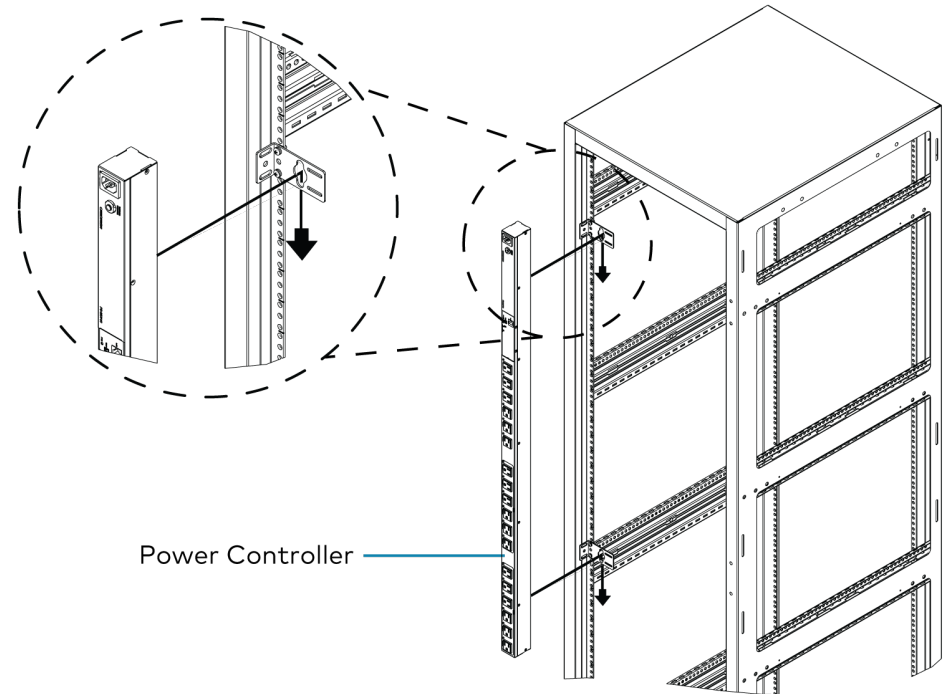

Vertical Networked Power Controller & Conditioner with Surge Protection and Metering

Mounting the Device Without Keyhole Mounts

1. Remove the screws and keyhole mounts from the device.

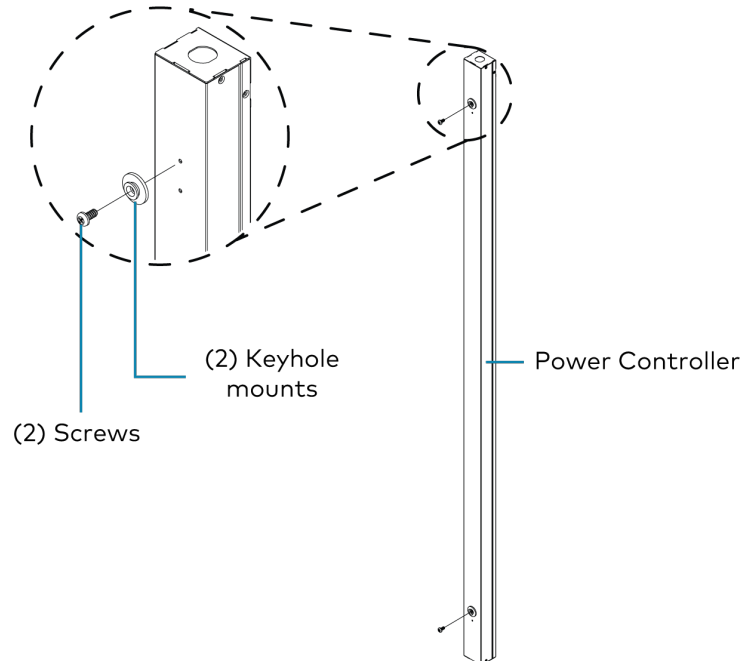

2. Store the keyhole mounts and screws for future use.
3. Use the four included mounting screws to attach the two included brackets to the rear of the device.

Brackets can be attached to the device using one of the following three methods. Follow the method that is best for your rack deployment to secure the device.

4. Use the rack mounting screws (not included) and washers (not included) to attach the assembled device to the rack angle.

Vertical Networked Power Controller & Conditioner with Surge Protection and Metering

Method 1

Attaching brackets to the power controller

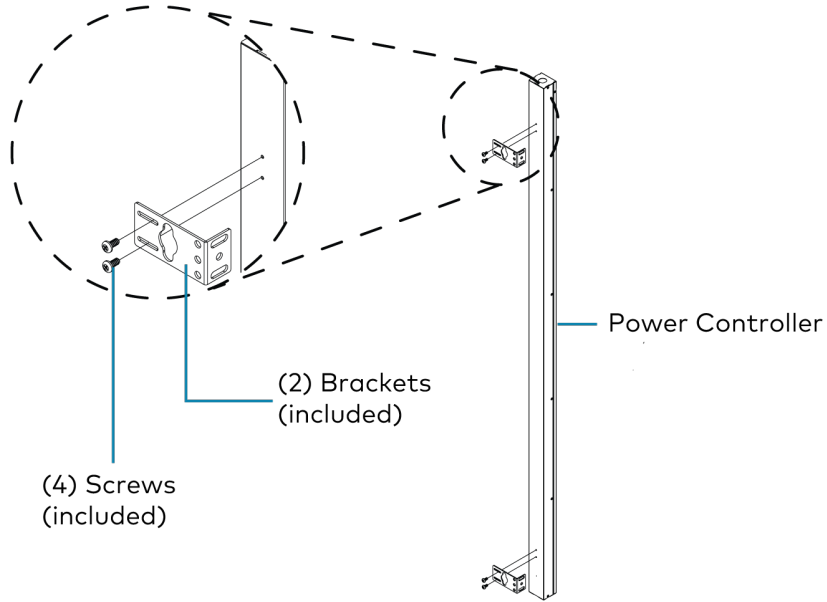

Attaching the assembly to the rack angle

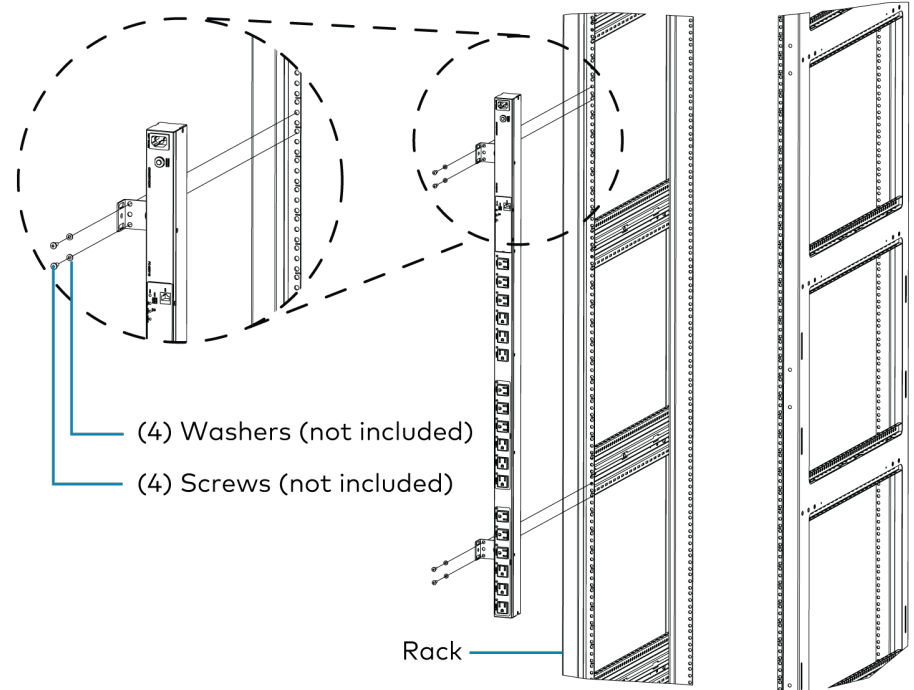

Vertical Networked Power Controller & Conditioner with Surge Protection and Metering

Method 2

Attaching brackets to the power controller

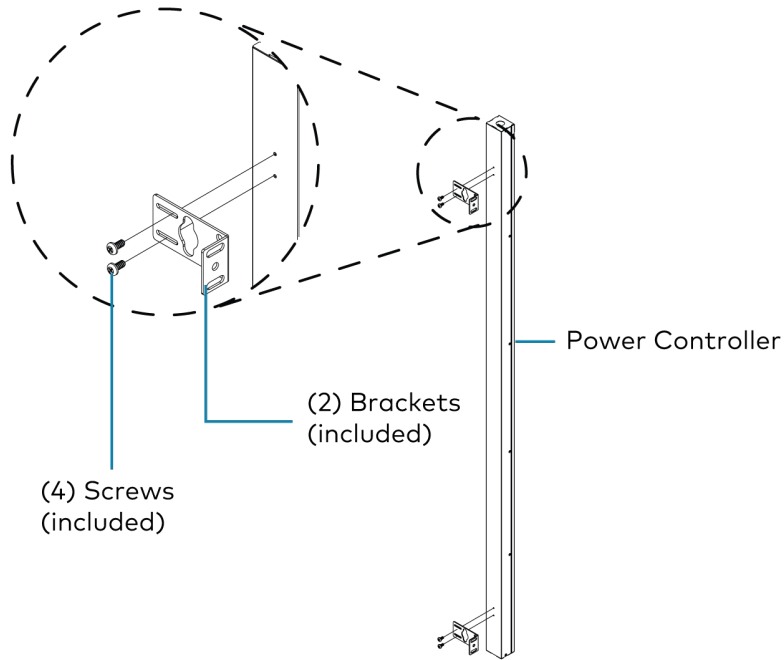

Attaching the assembly to the rack angle

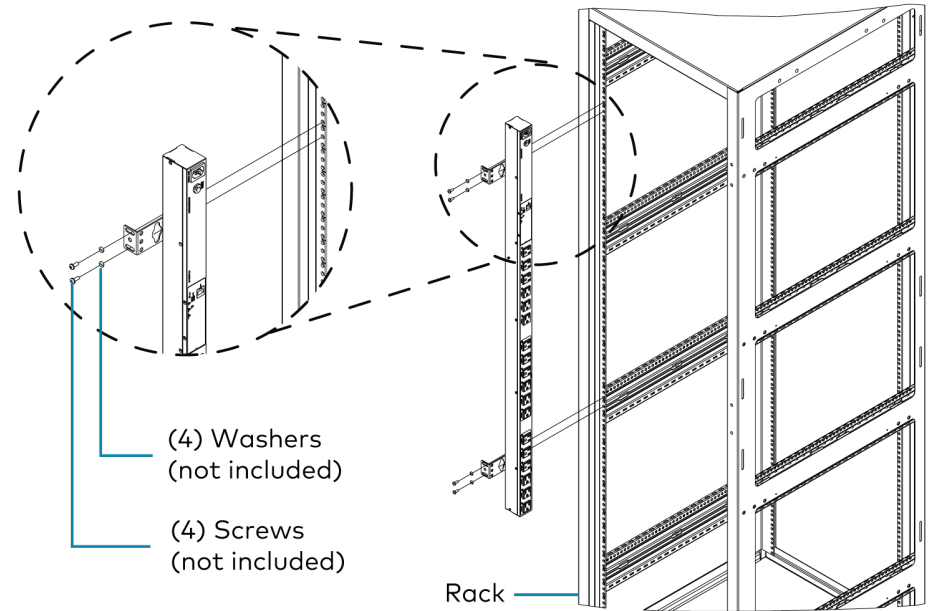

Vertical Networked Power Controller & Conditioner with Surge Protection and Metering

Method 3

Attaching brackets to the power controller

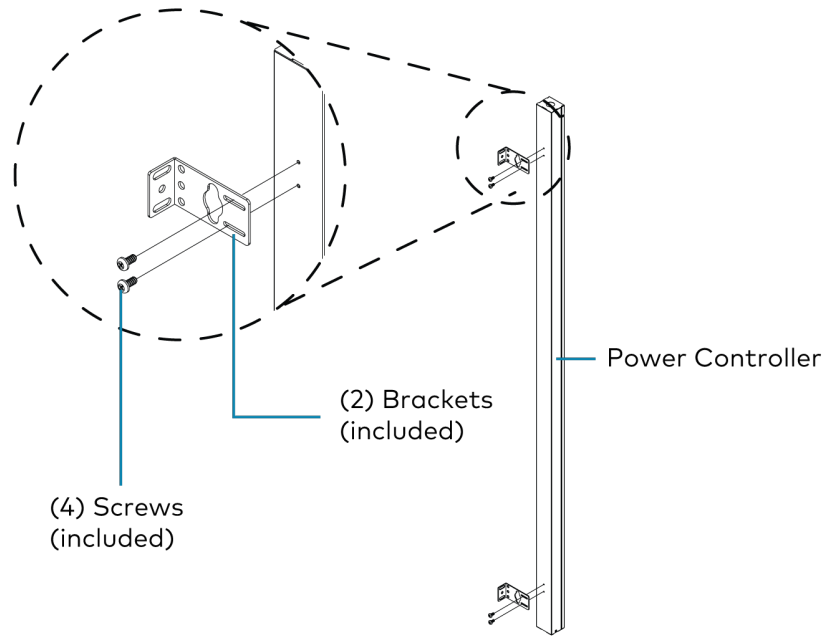

Attaching the assembly to the rack angle

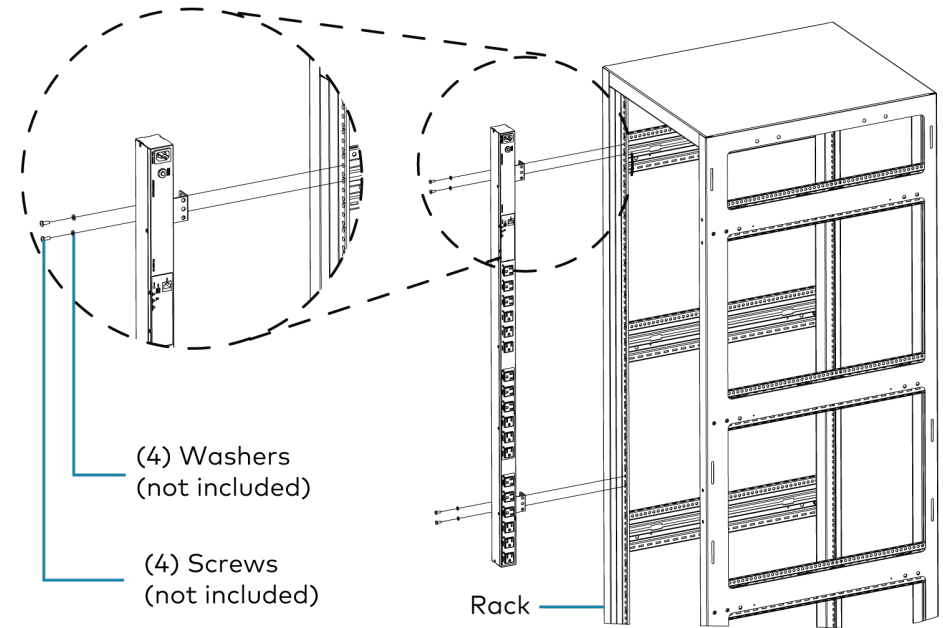

Vertical Networked Power Controller & Conditioner with Surge Protection and Metering

Outlet Test

Before making connections to the power controller, perform an outlet test to ensure that the outlet the power controller is plugged into is properly wired:

1. Connect the included power cord to the power controller.
2. Plug the power cord into the outlet and wait until the POWER LED and PROTECT LED on the power controller light green. This process may take several seconds.
3. Verify that the red **FAULT LED** is not lit.

If the **FAULT LED** lights, then the connected outlet is not wired correctly. Fault details can be viewed in the device web user interface. For more information on monitoring and configuring the device parameters, refer to the [PC-350V Series Product Manual](#).

NOTE: Do not make any connections to the device until the connected outlet is wired correctly.

4. Repeat steps 1 and 2 until the **FAULT LED** stops lighting when the power controller is plugged into the outlet.

Vertical Networked Power Controller & Conditioner with Surge Protection and Metering



Make Connections

Make the necessary connections as called out in the following illustration. Connect power last.

PC-350V-12

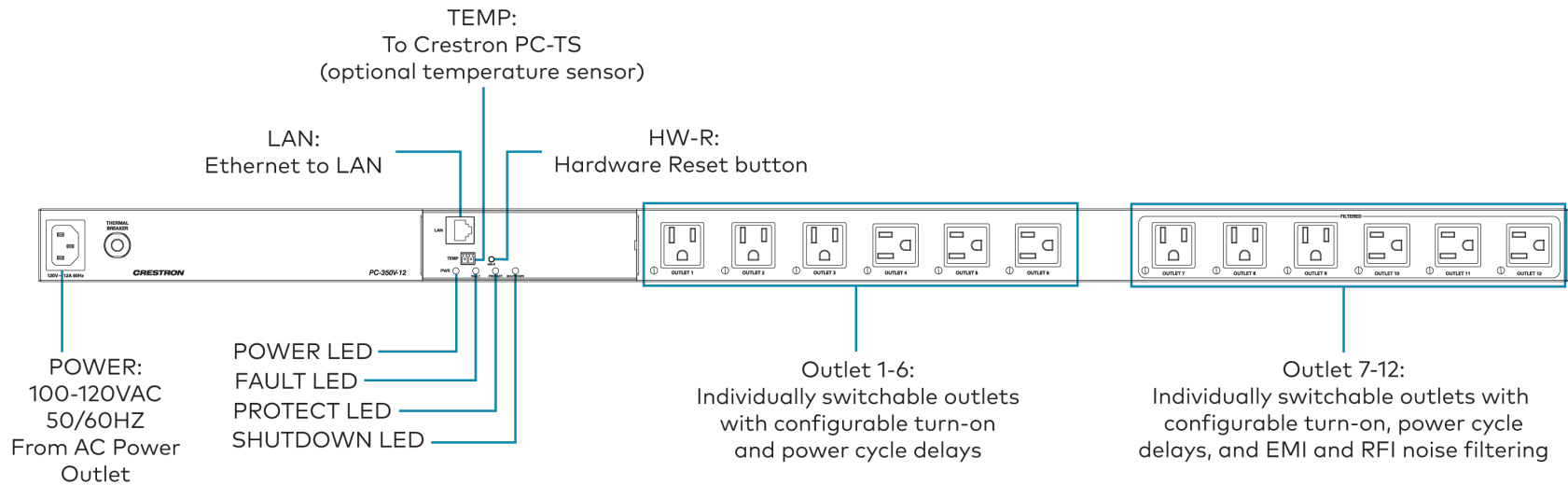

WARNING: If using a shielded Ethernet cable, exercise additional caution in verifying the inlet ground connection is established. The power controller may see a shielded Ethernet cable as a ground connection without an established life safety ground connection available at the inlet.

CAUTION: The PC-350V-12 must be plugged into a circuit that has a 20-amp or a 15-amp circuit breaker.

Vertical Networked Power Controller & Conditioner with Surge Protection and Metering

PC-350V-18

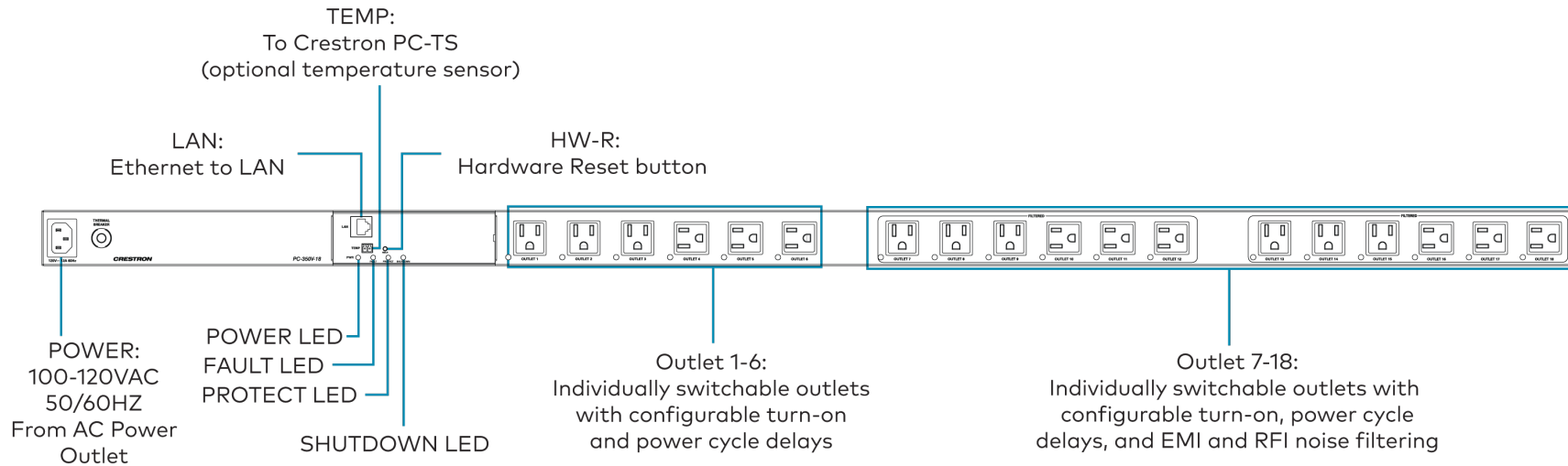

WARNING: If using a shielded Ethernet cable, exercise additional caution in verifying the inlet ground connection is established. The power controller may see a shielded Ethernet cable as a ground connection without an established life safety ground connection available at the inlet.

CAUTION: The PC-350V-18 must be plugged into a circuit that has a 20-amp or a 15-amp circuit breaker.

Vertical Networked Power Controller & Conditioner with Surge Protection and Metering



Reset the Device

A DHCP reset, hardware reset, factory restore, or power cycling all outlets may be performed when troubleshooting.

DHCP Reset

1. Ensure the device is powered on.
2. Press and hold the **HW-R** button for 1 second and release it for less than 2 seconds.
3. Repeat step 2 five times.

The device will reboot, and the network settings will be reset to default: default Hostname, DHCP enabled, and no static IP.

Hardware Reset

This process is equivalent to disconnecting the device from the power source and then reconnecting it to clear a fault.

1. Ensure the device is powered on.
2. Press and hold the **HW-R** button for at least 3 seconds and release.
The device will reboot.

Factory Restore

1. Ensure the device is powered on.
2. Press and hold the **HW-R** button for 15 seconds until all status LEDs blink twice to indicate the restore command has been executed successfully.

The PWR LED blinks amber during the factory restore process. The device will then reboot, and all factory settings will be restored.

CAUTION: Performing a factory restore will clear all settings from the device configuration.

Power Cycle All Outlets

1. Ensure the device is powered on.
2. Tap the **HW-R** button for less than 1 second.
The power cycling initiates for all outlets.

Vertical Networked Power Controller & Conditioner with Surge Protection and Metering



Observe the LED Indicators

Refer to the following table for information about the LED indicators on the device.

LED Indicator	Color	Meaning
PWR	Amber	The device is booting, factory reset in process, or the outlets have been shut off due to a fault condition.
	Green	The device is functioning normally.
	Blinking Green	The "Identify" search process is initiated.
FAULT	Red	Surge protection is compromised, line and neutral are reversed, or no ground is detected.
PROTECT	Green	Surge protection is functional.
SHUTDOWN	Amber	Power to outlets is shut off due to an overvoltage, undervoltage, overcurrent, line input miswire, missing ground, or compromised surge protection fault condition.
Per Outlet Indicator	Green	The outlet is turned on.
	Blinking Green	The "Identify" search process is initiated for the outlet.
LAN	Amber	Indicates Ethernet activity
	Green	Indicates Ethernet link status



Configure

Use the web user interface, SIMPL programming, or the Crestron Home® setup application to configure and monitor various components of the PC-350V-12 or PC-350V-18. For more information, refer to the product manual of the device.

Inlet Protections (Autosaved)

Current

Over Current Auto Cutoff Shut off last outlet Shut off all outlets

Over Current Cutoff amps

Voltage

Under voltage cutoff volts

Over voltage cutoff volts

Fault Protection

[Disable if connected to a UPS or generator that removes neutral to earth bonding](#)

Full Fault Protection

NOTE: Disabling the Full Fault Protection setting prevents the device from detecting miswire conditions and the ability to detect if some of the device's surge protection has been compromised. Disabling the Full Fault Protection setting will void the Connected Equipment Protection Warranty of the PC-350V. Your UPS may provide a Connected Equipment Protection Warranty in this instance.

Vertical Networked Power Controller & Conditioner with Surge Protection and Metering



Important Safety Instructions

- Installation must be completed by a professional.
- Equipotential bonding must be in place where the equipment is mounted.
- The power cord must be connected to an outlet with a properly earthed ground connection, as the device is earthed through the power cord connection at the inlet.

WARNING: The device power plug is designed to be inserted into a NEMA 5-15 (three-prong grounded) outlet only. Do not force the plug into an outlet that is not designed to accept it. Never dismantle the plug or alter the power cord, and do not attempt to defeat the grounding feature by using a 3-to-2 prong adapter. If you have questions about grounding, consult your local power company or a qualified electrician.

WARNING: If using a shielded Ethernet cable, exercise additional caution in verifying the inlet ground connection is established. The power controller may see a shielded Ethernet cable as a ground connection without an established life safety ground connection available at the inlet.

- Equipment is intended for installation in Restricted Access Area.
- Les matériels sont destinés à être installés dans des EMPLACEMENTS À ACCÈS RESTREINT.
- Suitable for installation in Information Technology Rooms in accordance with Article 645 of the National Electrical Code and NFPA 75.

- Peut être installé dans des salles de matériel de traitement de l'information conformément à l'article 645 du National Electrical Code et à la NFPA 75.

Vertical Networked Power Controller & Conditioner with Surge Protection and Metering



Visit the Product Page

Scan the QR code to visit the product page.

PC-350V-12



www.crestron.com/model/6511513

PC-350V-18



www.crestron.com/model/6511512

Additional Information

Original Instructions

The U.S. English version of this document is the original instructions. All other languages are a translation of the original instructions.

Regulatory Model: M202015002, M202015001

Crestron product development software is licensed to Crestron dealers and Crestron Service Providers (CSPs) under a limited nonexclusive, nontransferable Software Development Tools License Agreement. Crestron product operating system software is licensed to Crestron dealers, CSPs, and end-users under a separate End-User License Agreement. Both of these Agreements can be found on the Crestron website at www.crestron.com/legal/software_license_agreement.

The product warranty can be found at www.crestron.com/warranty.

The specific patents that cover Crestron products are listed at www.crestron.com/legal/patents.

Certain Crestron products contain open source software. For specific information, visit www.crestron.com/opensource.

Crestron, the Crestron logo, and Crestron Home are either trademarks or registered trademarks of Crestron Electronics, Inc. in the United States and/or other countries. Other trademarks, registered trademarks, and trade names may be used in this document to refer to either the entities claiming the marks and names or their products. Crestron disclaims any proprietary interest in the marks and names of others. Crestron is not responsible for errors in typography or photography.

©2022 Crestron Electronics, Inc.

Doc. 9061C

07/07/22