

Tabletop Mounting Kit for Zūm® Battery-Powered Wireless Keypads

The ZUMMESH-KP-BATT-TTK is a tabletop mounting kit for Zūm® Mesh battery-powered wireless keypads. The mounting kit enables the wireless keypad to control Zūm lighting systems from a conference room table or desk. The ZUMMESH-KP-BATT-TTK provides a quick and easy mounting solution for Zūm battery-powered keypads.



In the Box

Qty.	Description
1	ZUMMESH-KP-BATT-TTK, Tabletop Mounting Kit for Zūm® Battery-Powered Wireless Keypads
Additional Items	
1	Cover (2059759 or 2059760)
2	Screws, 4-40 x 3/8 in., Pan Head, Phillips, (2007169)

Assembled ZUMMESH-KP-BATT-TTK

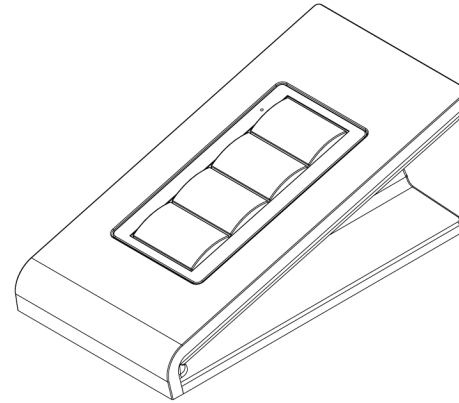

NOTE: Zūm Mesh battery-powered wireless keypad sold separately.

Tabletop Mounting Kit for Zūm® Battery-Powered Wireless Keypads



Assembly

The Zūm Mesh battery-powered wireless keypad is installed between the ZUMMESH-KP-BATT-TTK cover and base. The pieces are secured with two included screws via screw holes on the bottom of the base. Use a #1 Phillips tip screwdriver.

Top View

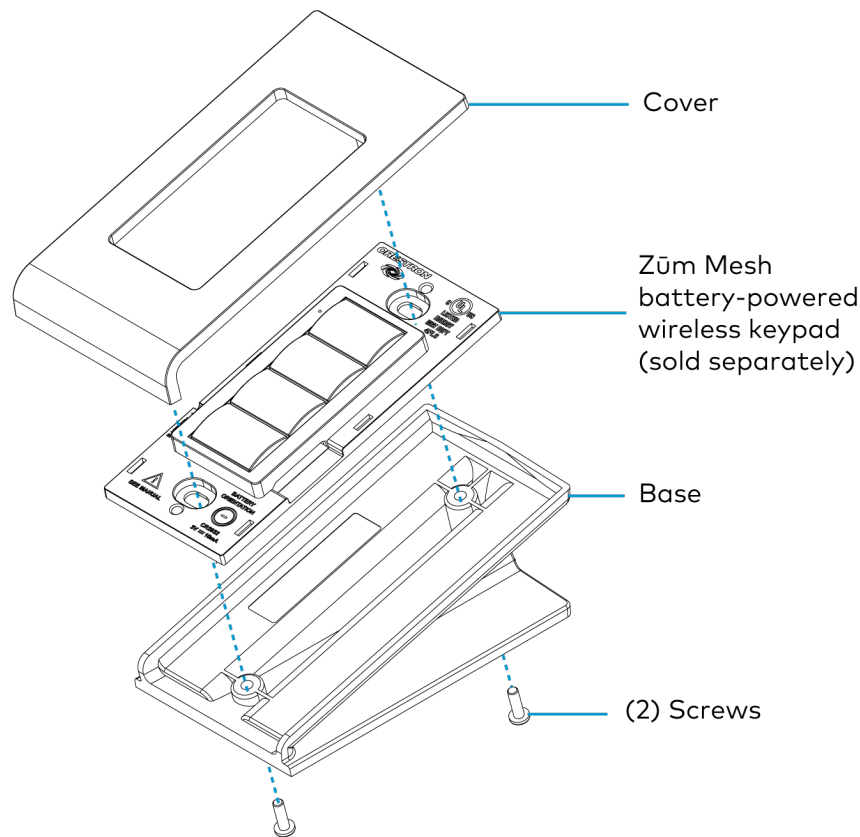

To assemble the kit:

1. Cradle the keypad inside the cover and lay the base on top of the keypad.
2. Align the holes and use the two included screws to secure all three pieces.

Bottom View

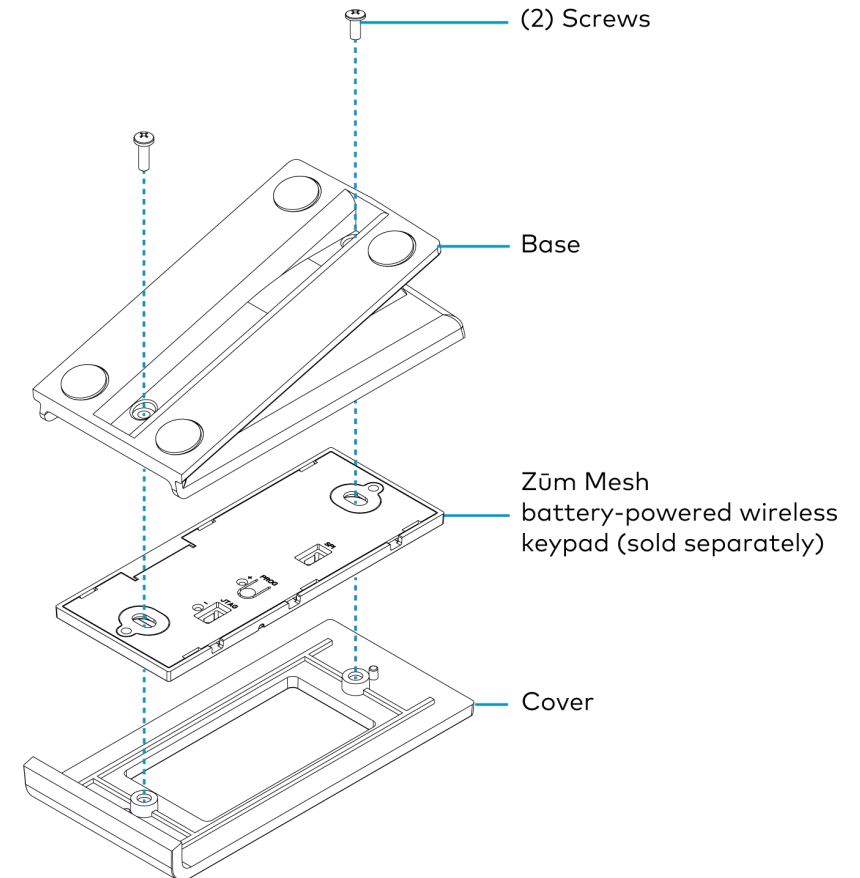

Tabletop Mounting Kit for Zūm® Battery-Powered Wireless Keypads

Additional Information

Original Instructions

The U.S. English version of this document is the original instructions. All other languages are a translation of the original instructions.

This product may be purchased from select authorized Crestron dealers and distributors. To find a dealer or distributor, please contact the Crestron sales representative for your area. A list of sales representatives is available online at www.crestron.com/How-To-Buy/Find-a-Representative or by calling 855-263-8754.

Crestron product development software is licensed to Crestron dealers and Crestron Service Providers (CSPs) under a limited nonexclusive, nontransferable Software Development Tools License Agreement. Crestron product operating system software is licensed to Crestron dealers, CSPs, and end-users under a separate End-User License Agreement. Both of these Agreements can be found on the Crestron website at www.crestron.com/legal/software_license_agreement.

The product warranty can be found at www.crestron.com/warranty.

The specific patents that cover Crestron products are listed online at www.crestron.com/legal/patents.

Certain Crestron products contain open source software. For specific information, please visit www.crestron.com/opensource.

Crestron, the Crestron logo, and Zūm are either trademarks or registered trademarks of Crestron Electronics, Inc. in the United States and/or other countries. Other trademarks, registered trademarks, and trade names may be used in this document to refer to either the entities claiming the marks and names or their products. Crestron disclaims any proprietary interest in the marks and names of others. Crestron is not responsible for errors in typography or photography.

©2022 Crestron Electronics, Inc.

Doc ID 9315A

11/08/22