

## Introduction

This document provides information about the various accessories that may be used with Crestron® shade products. Available accessories include:

- Crestron Pocket
- Closure Plates with Wall Clips
- Headbox
- U-Channel
- H-Channel
- Sill Angle
- Supplementary Items for Shade Side Channels:
  - ⇒ Channel Feed Ramps
  - ⇒ Side Channel Bottom Caps
  - ⇒ Side Channel Liners
  - ⇒ Side Channel Plugs

## Crestron Pocket

The Crestron pocket can be used in applications where a soffit or drop ceiling is installed. Using an optional closure allows the roller shade assembly to remain hidden from view.

Crestron pockets come in 12 foot (~3.5 meter) sections.

Refer to the following illustrations for dimensions of the Crestron pocket and closure.

*Crestron Pocket Dimensions  
(Shown with Optional 3 Inch Closure Plate)*

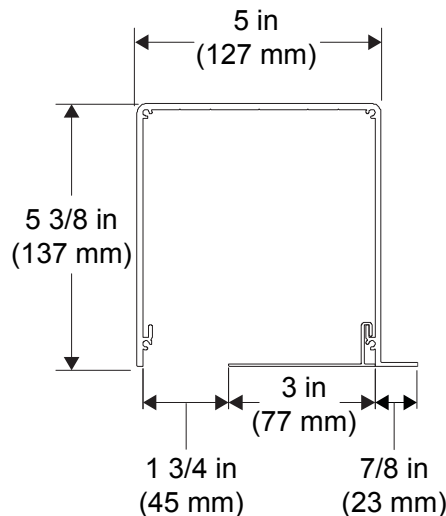

*Crestron Pocket Dimensions  
(Shown with Optional 1 1/2 Inch Closure Plate)*

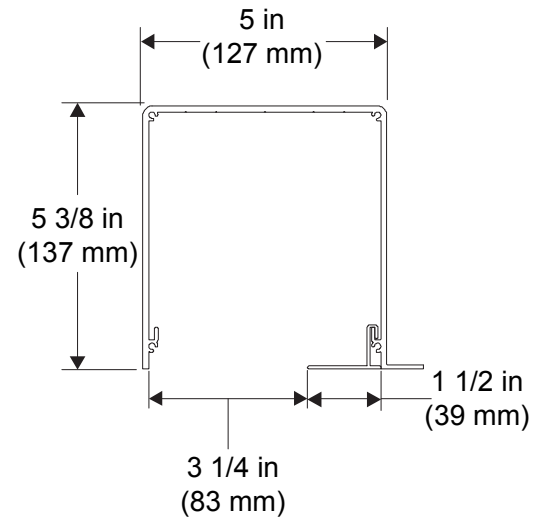

*Crestron Pocket Corner Dimensions*

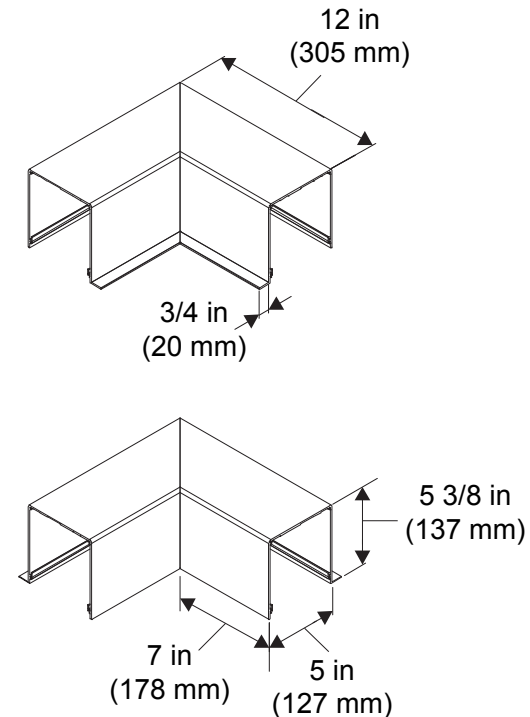

Refer to the following instructions to mount the Crestron pocket.

1. Accounting for corners and end caps in the measurements, measure and cut the pockets to the appropriate length.
2. Drill holes through pocket for wall or ceiling mount.



### Drill Holes for Mounting Crestron Pocket

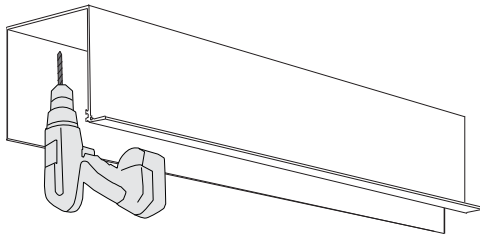

3. If using end caps, attach end caps to pocket using the supplied screws.

### Attach End Caps

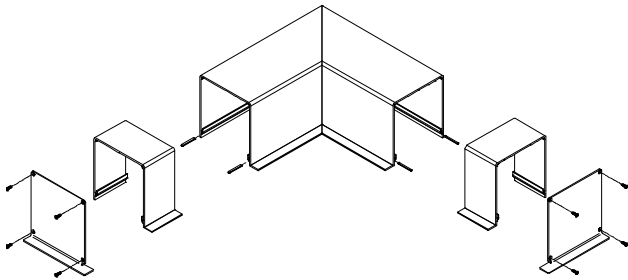

4. Mount pocket using hardware appropriate to mounting surface and conditions. If using alignment pins to connect pocket pieces, it may be easier to assemble the pocket pieces before mounting. If not using alignment pins, butt the edges against one another. They should not overlap.

**NOTE:** It is the responsibility of the installer to provide hardware appropriate for mounting surface and site conditions.

5. Prepare the pocket for shade installation
  - If installing motorized shades into the Crestron pocket, drill a hole for cable exit.
  - If installing a manual clutch shade into the Crestron pocket, trim closure to allow for cord clearance.
6. Install the roller shade assembly using the documentation supplied with the roller shade assembly.

**NOTE:** If installing a single shade make sure it is centered in the Crestron pocket.

7. Install closure plate onto wall clip as seen in the following illustration.

### Install Closure Plate

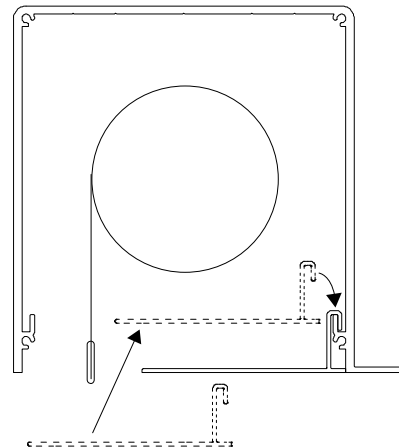

## Closure Plates with Wall Clips

Closure plates and wall clips are used to keep the shade assembly out of view. The wall clips mount to a mounting surface using standard hardware that is appropriate to the mounting scenario and provides a mounting point for the closure.

The closure plates are available in 1 1/2 in (39 mm) and 3 in (77 mm) widths that are designed for attachment to the lip of a wall clip, fascia or Crestron pocket. The closure plates are also available in a 5 in (127 mm) width and attaches to the lip of the wall clip when installed in a customer supplied pocket.

Closure plates and wall clips come in 12 foot (~3.5 meter) sections and must be cut to fit the space available. Measure and cut the wall clip and closure plate to fit the installation requirements.

Refer to the following illustrations for dimensions of the wall clips and closure plates.

### Closure Plate Dimensions

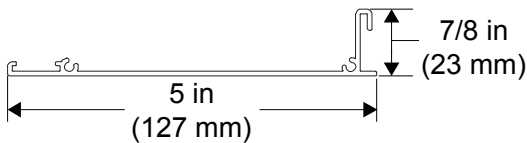
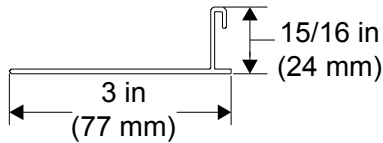
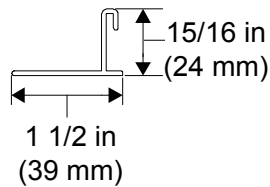

### Wall Clip Dimensions with Tile Lip

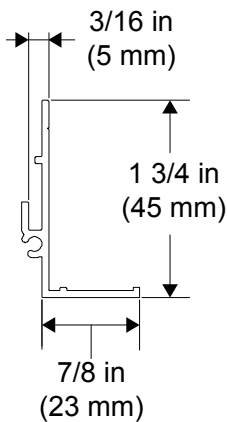

### Wall Clip Dimensions without Tile Lip

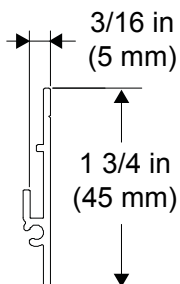

Refer to the following instructions to mount the wall clips and assembly of the closure plate.

**NOTE:** If installing manual clutch shades above the closure plate with wall clip, the closure plate may need to be trimmed to allow for cord clearance.

1. Attach wall clip to the mounting surface using hardware appropriate to mounting surface and conditions.

**NOTE:** It is the responsibility of the installer to provide hardware appropriate for mounting surface and site conditions.

2. Install the roller shade assembly using the documentation supplied with the roller shade assembly.
3. Install closure plate onto wall clip as seen in the illustration below.

### Installing the Closure Plate

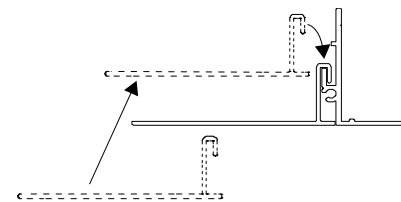

## Headbox

Mount the headbox according to type of roll (regular or reverse) that is to be installed in the headbox. Ensure that the closure plate clip is correctly oriented (towards the room or towards the window) as the closure plate can only clip onto one side of the headbox.

**NOTE:** The closure plate can only install on one side of the headbox.

A roller shade with a regular roll typically has the closure plate towards the room while a roller shade with a reverse roll has the closure plate towards the window. Refer to the illustration below for details

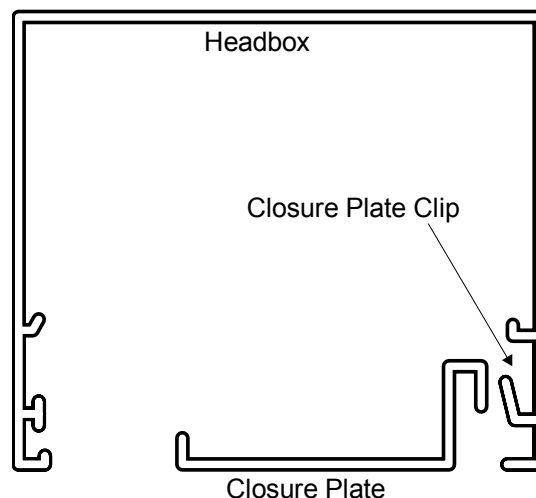

## U-Channel

Side channels allow blackout conditions by eliminating any light leaks between the window jamb and the fabric. The U-channel is designed for a single window opening and is installed on the left and right of the shade fabric.

U-channels come in 16 foot (~4.5 meter) lengths and must be cut to the height required.

Refer to the following illustration for dimensions of the U-channel.

### U-Channel Dimensions

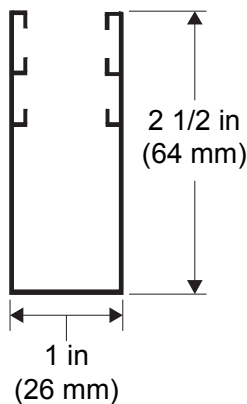

Refer to the following instructions to install the U-channel.

**NOTE:** Make sure to leave enough space at the top of the U-channels to keep the U-channel from interfering with shade operation. If using with motorized shades, set limit switch so the shade slat does not come up out of the U-channel. If using with manual clutch shades, install stop balls onto cord so the shade slat does not come up out of the U-channel.

1. Measure and cut U-channel to fit installation requirements.
2. Drill 3/8" holes in U-channels for mounting to wall or jamb.

**NOTE:** U-channels are not compatible with all Crestron shade products.

3. Attach using hardware appropriate to mounting surface and conditions.

### Attach U-Channel – Face Mount

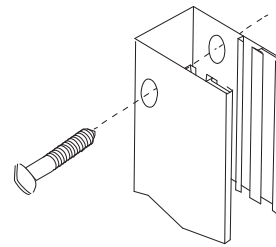

### Attach U-Channel – Jamb Mount

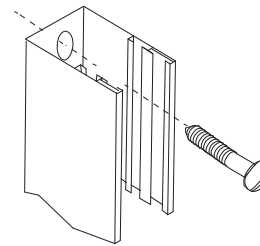

**NOTE:** It is the responsibility of the installer to provide hardware appropriate for mounting surface and site conditions.

4. Use provided color-matched plugs to cover outer screw holes.

Crestron offers supplementary parts for use with the U-channel. Refer to “Supplementary Items for Shade Side Channels” which starts on page 5 for details.

## H-Channel

Side channels allow blackout conditions by eliminating any light leaks between the window jamb and the fabric. H-channel is designed to be installed between two adjacent shades.

H-channels come in 16 foot (~4.5 meter) lengths and must be cut to the height required.

Refer to the following illustration for dimensions of the H-channel.

### H-Channel Dimensions

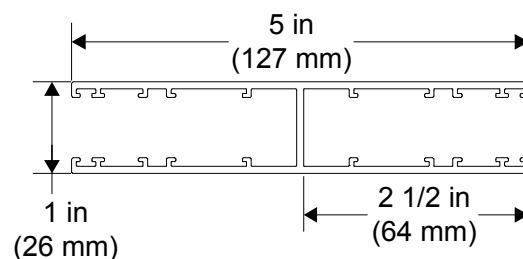

Refer to the following illustration for dimensions of the H-channel.

**NOTE:** Make sure to leave enough space at the top of the side channels to keep the H-channel from interfering with shade operation. If using with motorized shades, set limit switch so the shade slat does not come up out of the H-channel. If using with manual clutch shades, install stop balls onto cord so the shade slat does not come up out of the H-channel.

1. Measure and cut to fit installation requirements.
2. Drill 3/8" holes in H-channel for mounting to wall or jamb.

**NOTE:** H-channels are not compatible with all Crestron shade products.

3. Attach using hardware appropriate to mounting surface and conditions.

**NOTE:** It is the responsibility of the installer to provide hardware appropriate for mounting surface and site conditions.

4. Use provided color-matched plugs to cover outer screw holes.

Crestron offers supplementary parts for use with the H-channel. Refer to "Supplementary Items for Shade Side Channels" which starts on page 5 for details.

### Sill Angle Dimensions - Small

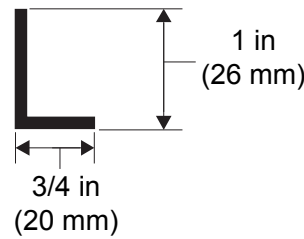

Refer to the following instructions to mount the sill angle.

1. Measure and cut to fit installation requirements.
2. Drill holes in sill angles for mounting to the sill.
3. Attach using hardware appropriate to mounting surface and conditions.

### Mount Sill Angles

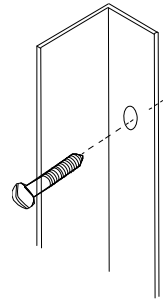

**NOTE:** It is the responsibility of the installer to provide hardware appropriate for mounting surface and site conditions.

## Sill Angle

The sill angle allows blackout conditions by eliminating any light leaks between the window sill and the fabric.

Sill angles come in 12 foot 3 inch (3/4 in x 1 in) or 16 foot (1 in x 2 3/4 in) lengths and must be cut to the length required.

Refer to the following illustrations for dimensions of the sill angle.

### Sill Angle Dimensions - Large

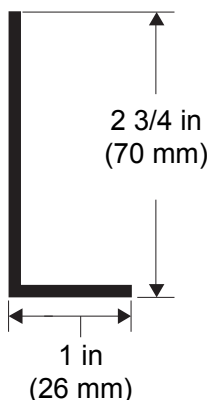

## Supplementary Items for Shade Side Channels

Crestron provides the following additional parts that may be needed to complete shade systems using U- or H-channels. These accessories can be purchased separately when ordering pre-cut or stock length.

### Channel Feed Ramps

Channel feed ramps allow the shades fabric to leave the roller and enter the side channel smoothly without fear of being snagged, especially when channels are manually cut in the field and may have rough edges. Insert the channel feed ramp into the top of the side channel.

## *Install Channel Feed Ramp*

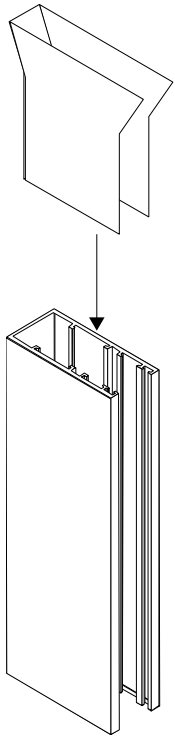

## **Side Channel Bottom Caps**

Side channel bottom caps provide a clean end cap to the side channel as it sits on top of a window sill. Insert the side channel bottom cap to the bottom of the side channel

## *Install Side Channel Bottom Cap*

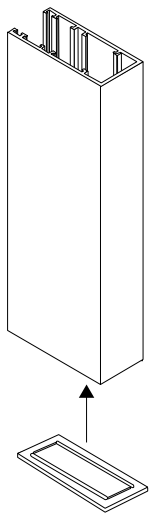

## **Side Channel Liners**

Side channel liners are made of a special fabric that slides inside the U- or H-channel and provides a tighter fit for the shade to ensure proper blackout capability for thinner fabrics.

## *Install Side Channel Liners*

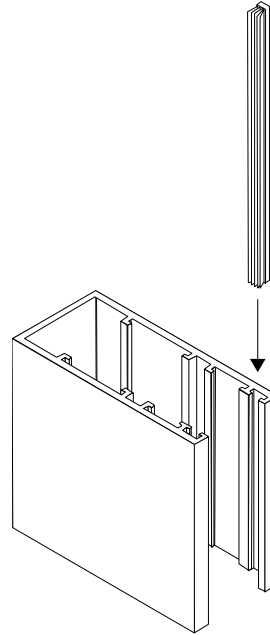

## **Side Channel Plugs**

Side channel plugs are designed to cover up the mounting screws when drilling through the outside of the channel. After installation of the side channel press the plugs into the holes created from drilling the side channel.

## *Side Channel Plugs*

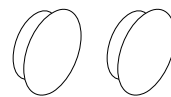

## *Installing Side Channel Plugs*

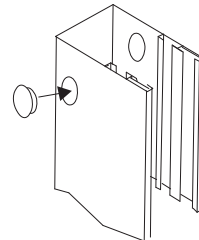

## Further Inquiries

To locate specific information or resolve questions after reviewing this guide, contact Crestron's True Blue Support at 1-888-CRESTRON [1-888-273-7876] or, for assistance within a particular geographic region, refer to the listing of Crestron worldwide offices at [www.crestron.com/offices](http://www.crestron.com/offices).

To post a question about Crestron products, log onto Crestron's Online Help at [www.crestron.com/onlinehelp](http://www.crestron.com/onlinehelp). First-time users must establish a user account to fully benefit from all available features.

---

## Future Updates

As Crestron improves functions, adds new features and extends the capabilities of the Crestron Shade Accessories, additional information may be made available as manual updates. These updates are solely electronic and serve as intermediary supplements prior to the release of a complete technical documentation revision.

Check the Crestron Web site periodically for manual update availability and its relevance. Updates are identified as an "Addendum" in the Download column.

The specific patents that cover Crestron products are listed at [patents.crestron.com](http://patents.crestron.com).

Crestron and the Crestron logo are either trademarks or registered trademarks of Crestron Electronics, Inc. in the United States and/or other countries. Other trademarks, registered trademarks and trade names may be used in this document to refer to either the entities claiming the marks and names or their products. Crestron disclaims any proprietary interest in the marks and names of others. *Crestron is not responsible for errors in typography or photography.*

This document was written by the Technical Publications department at Crestron.  
©2014 Crestron Electronics, Inc.

## Crestron Shading Solutions Standard Limited Warranty

This limited warranty (“Warranty”) is applicable to (a) Crestron Shading Solutions control system shade fabric, shade mounting hardware including tracks and roller tubes, and shade motors (collectively “Hardware”) and (b) Crestron Shading Solutions control system wall controls, interfaces and system accessories, (“External Components” and , with the Hardware the “Shading Solutions System”). Batteries are excluded from External Components and are not covered under this warranty. Customer acknowledges and agrees that use of the Shading Solutions System, or any part thereof, constitutes acceptance of all terms and conditions of this Warranty.

### Limited Warranty

Subject to the exclusions and restrictions and for the periods of time described in this Warranty, Crestron warrants that the Shading Solutions System will be free from manufacturing defects under normal use. If any manufacturing defect exists in any Hardware or External Component during the periods of time identified below from the date of shipment by Crestron, as long as Customer promptly notifies Crestron of the defect and, if requested by Crestron, upon the return of the defective part(s), Crestron will, at its option, either repair the defective part(s), or provide comparable replacement part(s) or issue a credit to the Customer against the purchase price of comparable replacement part(s) purchased from Crestron as noted in the schedule below.

Number of Years from Date of Shipment, as applicable	Percentage Warranted by Crestron for Hardware
Up to 5	100%
More than 5 but not more than 8	50%
More than 8	0%

Crestron warrants that External Components, excluding batteries, will be free from manufacturing defects under normal use from date of shipment by Crestron for a period of (a) one (1) year as to the power supplies, (b) ninety (90) days as to touch screen displays and overlay components, (c) three (3) years as to other External Components. Replacement parts for the Shading Solutions System provided by Crestron or, at its sole discretion, an approved vendor may be new, used, repaired, reconditioned and/or made by a different manufacturer.

### EXCLUSIONS AND RESTRICTIONS

This Warranty does not cover, and Crestron and its suppliers are not responsible for:

- Damage, malfunction, or inoperability diagnosed by Crestron or a Crestron approved third-party as being caused by normal wear and tear, abuse, misuse, incorrect installation, neglect, accident, interference, or adverse environmental factors.
 

Such environmental factors shall include, but not be limited to: (a) use of incorrect line voltages; (b) improperly rated fuses or circuit breakers; (c) failure to install, maintain, and operate the System pursuant to the operating instructions provided by Crestron; (d) failure to comply with the applicable provisions of the National Electrical Code and Safety Standards of Underwriters Laboratories; (e) use of incompatible devices or accessories; (f) improper or insufficient ventilation; (g) unauthorized repairs or adjustments; (h) vandalism including a virus or computer hacker; (i) acts of God, such as fire, lightning, flooding, tornado, earthquake, hurricane or other problems beyond Crestron’s control; or (j) failure to maintain equipment under the specified ambient temperature limits.
- On-site labor costs to diagnose issues with, and to remove, repair, replace, adjust, reinstall and/or reprogram the Shading Solutions System or any of its components.
- Components and equipment external to the Shading Solutions System, such as, but not limited to: (a) lamps, sockets, and fixtures; (b) fixture wiring between ballasts and lamps; (c) building wiring between the dimmer panels and lamps; (d) wiring between the control panels; (e) audio-visual equipment; and (f) other non-Crestron equipment such as motion detectors.
- The cost of repairing or replacing other property that is damaged when the Shading Solutions System does not work properly, even if the damage was caused by the Shading Solutions System.
- Any loss of software or data. Customer has sole responsibility to properly back up all data on any other storage device(s) in the Shading Solutions System.
- Repairs required due to malfunctions caused by non-Crestron supplied software.

EXCEPT AS EXPRESSLY PROVIDED IN THIS WARRANTY, THERE ARE NO EXPRESS OR IMPLIED WARRANTIES OF ANY TYPE, INCLUDING ANY IMPLIED WARRANTIES OF FITNESS FOR A PARTICULAR PURPOSE OR MERCHANTABILITY.

CRESTRON DOES NOT WARRANT THAT THE SHADING SOLUTIONS SYSTEM WILL OPERATE WITHOUT INTERRUPTION OR BE ERROR FREE.

NO CRESTRON AGENT, EMPLOYEE, OR REPRESENTATIVE HAS ANY AUTHORITY TO BIND CRESTRON TO ANY AFFIRMATION, REPRESENTATION, OR WARRANTY CONCERNING THE SHADING SOLUTIONS SYSTEM.

UNLESS AN AFFIRMATION, REPRESENTATION OR WARRANTY MADE BY AN AGENT, EMPLOYEE OR REPRESENTATIVE IS SPECIFICALLY INCLUDED HEREIN, OR IN STANDARD PRINTED MATERIALS PROVIDED BY CRESTRON, IT DOES NOT FORM A PART OF THE BASIS OF ANY BARGAIN BETWEEN CRESTRON AND CUSTOMER AND WILL NOT IN ANY WAY BE ENFORCEABLE BY CUSTOMER.

IN NO EVENT WILL CRESTRON OR ANY OTHER PARTY BE LIABLE FOR EXEMPLARY, CONSEQUENTIAL, INCIDENTAL OR SPECIAL DAMAGES (INCLUDING, BUT NOT LIMITED TO, DAMAGES FOR LOSS OF PROFITS, CONFIDENTIAL OR OTHER INFORMATION, OR PRIVACY; BUSINESS INTERRUPTION; PERSONAL INJURY; FAILURE TO MEET ANY DUTY, INCLUDING OF GOOD FAITH OR OF REASONABLE CARE; NEGLIGENCE, OR ANY OTHER PECUNIARY OR OTHER LOSS WHATSOEVER), NOR FOR ANY REPAIR WORK UNDERTAKEN WITHOUT CRESTRON’S WRITTEN CONSENT ARISING OUT OF OR IN ANY WAY RELATED TO THE INSTALLATION, DEINSTALLATION, USE OF OR INABILITY TO USE THE SHADING SOLUTIONS SYSTEM OR OTHERWISE UNDER OR IN CONNECTION WITH ANY PROVISION OF THIS WARRANTY, OR ANY AGREEMENT INCORPORATING THIS WARRANTY, EVEN IN THE EVENT OF THE FAULT, TORT (INCLUDING NEGLIGENCE), STRICT LIABILITY, BREACH OF CONTRACT OR BREACH OF WARRANTY OF CRESTRON OR ANY SUPPLIER, AND EVEN IF CRESTRON OR ANY OTHER PARTY WAS ADVISED OF THE POSSIBILITY OF SUCH DAMAGES.

NOTWITHSTANDING ANY DAMAGES THAT CUSTOMER MIGHT INCUR FOR ANY REASON WHATSOEVER (INCLUDING, WITHOUT LIMITATION, ALL DIRECT DAMAGES AND ALL DAMAGES LISTED ABOVE), THE ENTIRE LIABILITY OF CRESTRON AND OF ALL OTHER PARTIES UNDER THIS WARRANTY ON ANY CLAIM FOR DAMAGES ARISING OUT OF OR IN CONNECTION WITH THE MANUFACTURE, SALE, INSTALLATION, DELIVERY, USE, REPAIR, OR REPLACEMENT OF THE SHADING SOLUTIONS SYSTEM, OR ANY AGREEMENT INCORPORATING THIS WARRANTY, AND CUSTOMER’S SOLE REMEDY FOR THE FOREGOING, WILL BE LIMITED TO THE AMOUNT PAID TO CRESTRON BY CUSTOMER FOR THE SHADING SOLUTIONS SYSTEM. THE FOREGOING LIMITATIONS, EXCLUSIONS, AND DISCLAIMERS WILL APPLY TO THE MAXIMUM EXTENT ALLOWED BY APPLICABLE LAW, EVEN IF ANY REMEDY FAILS ITS ESSENTIAL PURPOSE.

### To Make A Warranty Claim

To make a warranty claim, promptly notify Crestron within the warranty periods described above by calling the Crestron Technical Support Center at 1-888-CRESTRON. Crestron, in its sole discretion, will determine what action, if any, is required under this Warranty.

Most Shading Solutions System problems can be corrected over the phone through close cooperation between Customer and a Crestron technician. To better enable Crestron to address a warranty claim, please have the Shading Solutions System’s serial and model numbers, its current operating system version, and the brand names and models of any peripheral devices (such as a modem) used with the Shading Solutions System available when making the call.

If Crestron, in its sole discretion, determines that an on-site visit or other remedial action is necessary, Crestron may send a representative or coordinate the dispatch of a representative from a Crestron approved vendor, to Customer’s site, and/or coordinate a warranty service call between Customer and a Crestron approved vendor.

All on-site labor costs incurred to diagnose any problems with the Shading Solutions System and to repair, replace or adjust (at Crestron’s option) the Shading Solutions System to restore it to normal operation will be paid by customer at the then current service price unless covered by a separate Crestron Support and Maintenance Plan.