

Crestron **CEN-HPRFGW**
High Powered RF Gateway

Operations & Installation Guide



This document was prepared and written by the Technical Documentation department at:



Crestron Electronics, Inc.
15 Volvo Drive
Rockleigh, NJ 07647
1-888-CRESTRON

Industry Compliance

As of the date of manufacture, the CEN-HPRFGW has been tested and found to comply with specifications for CE marking and standards per EMC and Radiocommunications Compliance Labelling.



Federal Communications Commission (FCC) Compliance Statement

This device complies with part 15 of the FCC rules. Operation is subject to the following conditions: (1) this device may not cause harmful interference and (2) this device must accept any interference received, including interference that may cause undesired operation.

CAUTION: Changes or modifications not expressly approved by the manufacturer responsible for compliance could void the user's authority to operate the equipment.

NOTE: This equipment has been tested and found to comply with the limits for a Class B digital device, pursuant to part 15 of the FCC rules. These limits are designed to provide reasonable protection against harmful interference in a residential installation. This equipment generates, uses and can radiate radio frequency energy and if not installed and used in accordance with the instructions, may cause harmful interference to radio communications. However, there is no guarantee that interference will not occur in a particular installation. If this equipment does cause harmful interference to radio or television reception, which can be determined by turning the equipment off and on, the user is encouraged to try to correct the interference by one or more of the following measures:

- Reorient or relocate the receiving antenna
 - Increase separation between the equipment and the receiver
 - Connect the equipment into an outlet on a circuit different from that to which the receiver is connected
 - Consult the dealer or an experienced radio/TV technician for help
-

Contents

High Powered RF Gateway: CEN-HPRFGW	1
Introduction	1
Features and Functions	2
Specifications	2
Physical Description	5
Setup	10
Network Wiring	10
Identity Code	10
Supplied Hardware	11
Installation	11
Hardware Hookup	13
Programming Software	15
Earliest Version Software Requirements for the PC	15
Programming with Crestron SystemBuilder	15
Programming with SIMPL Windows	15
Example Program	18
Uploading and Upgrading	19
Establishing Communication	19
Programs and Firmware	21
Program Checks	22
Operation	23
Problem Solving	25
Troubleshooting	25
Check Network Wiring	28
Reference Documents	29
Further Inquiries	29
Future Updates	30
Appendix A: The RF Spectrum	31
Appendix B: Optimum RF Reception Guidelines	32
Minimize Interference	32
Gateway Placement	32
Antenna Orientation	33
Return and Warranty Policies	35
Merchandise Returns / Repair Service	35
CRESTRON Limited Warranty	35

High Powered RF Gateway: CEN-HPRFGW

Introduction

The CEN-HPRFGW gateway is an RF transceiver that enables the Isys[®] TPS-6X wireless touchpanel to communicate with a 2-Series control system. Wi-Fi friendly RF technology permits selection from 16 ISM channels within the 2.4 GHz spectrum to minimize the possibility of interference with other RF equipment including 802.11 devices. The CEN-HPRFGW affords a range of approximately 100 to 200 feet (30 to 61 meters) indoors and up to 1000 feet (305 meters) outdoors.

Up to 16 touchpanels may be associated with a single CEN-HPRFGW gateway. Setup is simple, utilizing dynamic discovery to locate and acquire each touchpanel automatically. Each wireless connection is monitored continuously, diligently keeping track when touchpanels go to sleep, shut down or wander out of range and restoring communications seamlessly when any touchpanel reappears on the network. The control data to and from each associated touchpanel is passed cleanly and quickly through the gateway without any cumbersome processing to effect performance. Excessive network traffic and noise are combated using intelligent data routing to ensure every control signal is delivered intact to its intended destination without interruption.

Multiple CEN-HPRFGW units can be used to allow roaming with the TPS-6X touchpanel.

The CEN-HPRFGW and the CENI-HPRFGW (international version) are functionally identical. For simplicity within this guide, CEN-HPRFGW is used except where noted.

Features and Functions

- 2-way RF wireless transceiver/gateway
- Supports up to 16 TPS-6X touchpanels
- Dynamic discovery for fast, easy setup
- Wi-Fi friendly channel selection
- Built-in RF network diagnostics
- Range: 100-200 feet (30-61 meters) indoors, 1000 feet (305 meters) outdoors
- Crestron Toolbox™ software configuration and management
- Cresnet® or Ethernet control system interface

Specifications

Specifications for the CEN-HPRFGW are listed in the following table.

CEN-HPRFGW Specifications

SPECIFICATION	DETAILS
Wireless	
RF Transceiver	2-way, RF, 2.4 GHz ISM channels 11-26 (2400 to 2483.5 MHz), IEEE 802.15.4 compliant
RF Transmitting Power	75 mW (Ch. 11), 100 mW (Ch. 12-23), 15 mW (Ch. 24), 3.5 mW (Ch. 25), 1 mW (Ch. 26) @ High setting; 1 mW (Ch. 11-25), 0.5 mW (Ch. 26) @ Low setting
Range (typical)	100-200 feet (30-61 meters) maximum indoor, 1000 feet (305 meters) outdoor, subject to site-specific conditions; Maximum 16 touchpanels per gateway

(Continued on following page)

CEN-HPRFGW Specifications (Continued)

SPECIFICATION	DETAILS
Ethernet	10BASE-T/100BASE-TX, auto-switching, auto-negotiating, auto-discovery, full/half duplex, TCP/IP, UDP/IP, CIP, DHCP, IEEE 802.3U compliant
Power Requirements 12 VDC Power Supply	0.5 Amps @ 12 Volts DC CEN-HPRFGW: 120 Volts AC @ 60 Hz (power supply included) CENI-HPRFGW: 230 Volts AC @ 50 Hz (power supply included)
Cresnet Power Usage	2 Watts (85mA @ 24 Volts DC) with no power supply connected to the 12VDC connector
Default Net ID	2F
Minimum 2-Series Control System Update File ^{1, 2}	Version 3.155.1240 or later
Enclosure	Metal, black matte powder coat finish, freestanding or surface mount (adhesive feet, 3M™ Dual Lock™ reclosable fastener and mounting plate included)
Environmental Temperature Humidity Heat Dissipation	41° to 104°F (5° to 40°C) 10% to 90% RH (non-condensing) 5 BTU/Hr

(Continued on following page)

CEN-HPRFGW Specifications (Continued)

SPECIFICATION	DETAILS
Dimensions	
Height	1.30 in (3.30 cm) with feet 1.22 in (3.09 cm) without feet
Width	4.28 in (10.86 cm)
Depth	5.60 in (14.22 cm)
Weight	15 oz (414 g)
Included Accessories	Power Pack

1. The latest software versions can be obtained from the Crestron[®] website. Refer to the NOTE following these footnotes.
2. Crestron 2-Series control systems include the AV2 and PRO2. Consult the latest Crestron Product Catalog for a complete list of 2-Series control systems.

NOTE: Crestron software and any files on the website are for authorized Crestron dealers and Crestron Authorized Independent Programmers (CAIP) only. New users may be required to register to obtain access to certain areas of the site (including the FTP site).

Physical Description

This section provides information on the connections, controls and indicators available on your CEN-HPRFGW.

CEN-HPRFGW Physical View



CEN-HPRFGW (Front View)

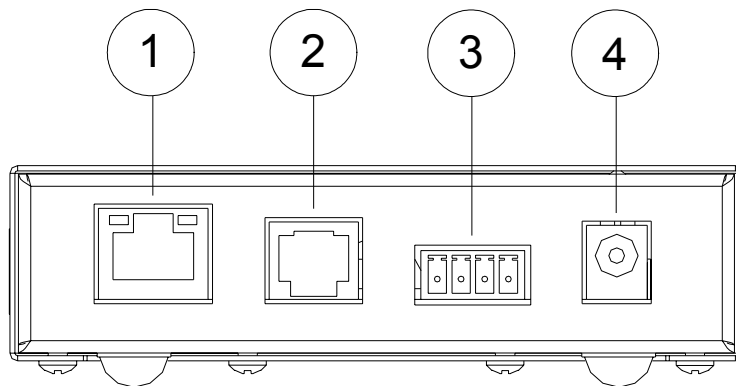

CEN-HPRFGW Overall Dimensions (Top View)

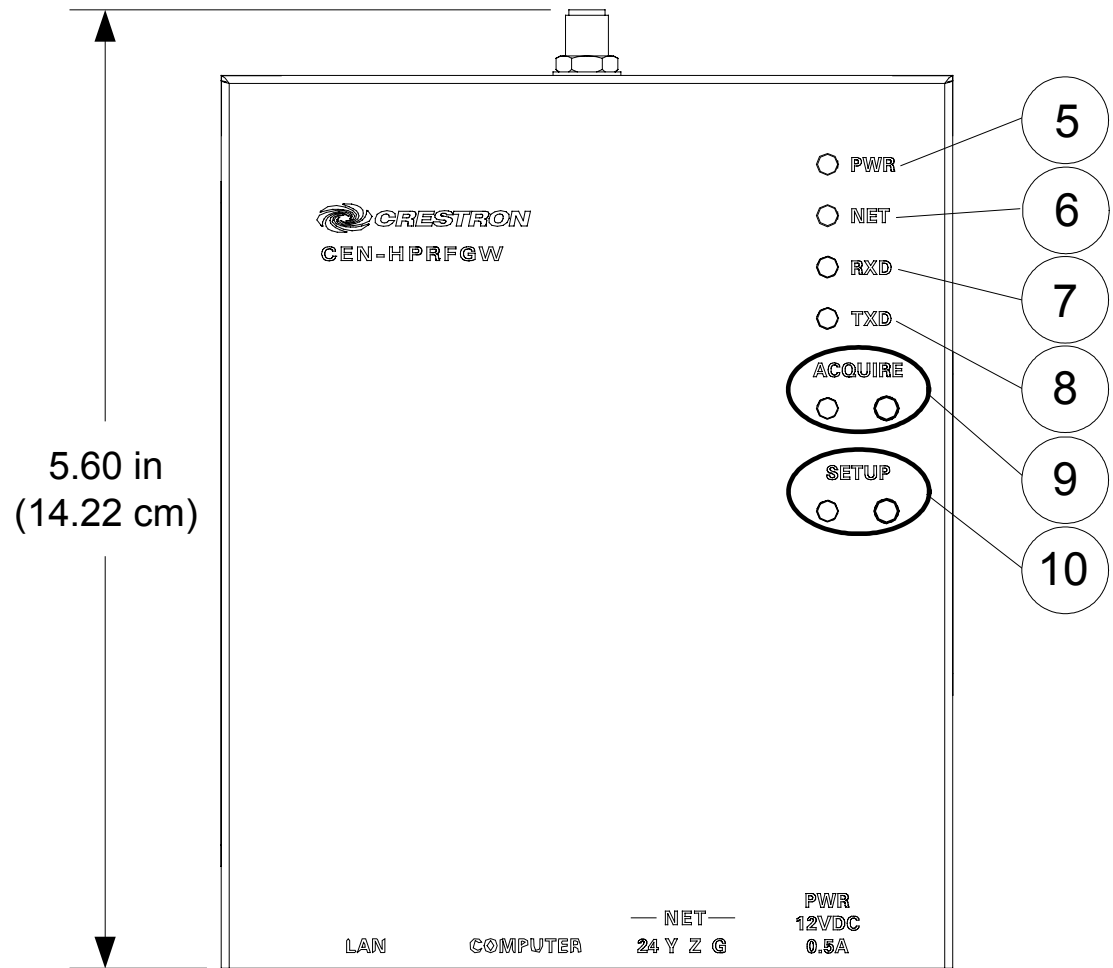

CEN-HPRFGW Overall Dimensions (Rear View)

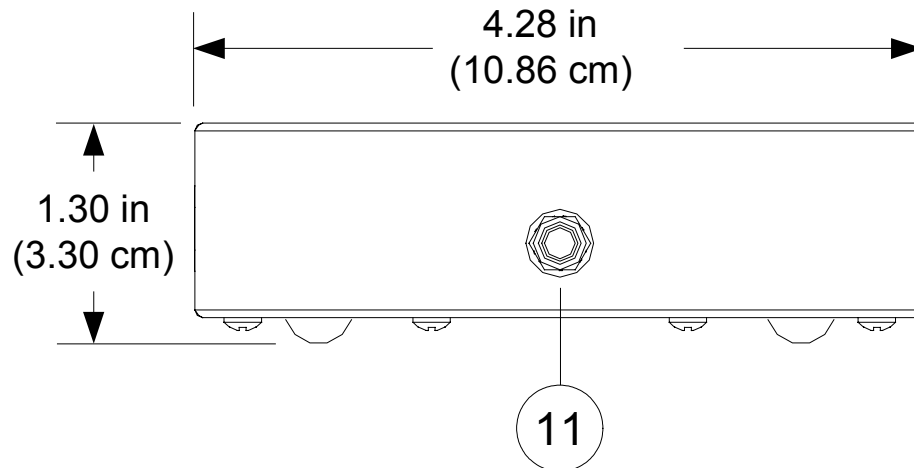

Connectors, Controls & Indicators

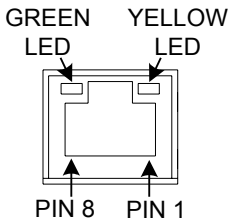
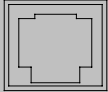
#	CONNECTORS ¹ , CONTROLS & INDICATORS	DESCRIPTION																				
1	<p style="text-align: center;">LAN²</p> 	<p>(1) 8-wire RJ-45 with two LED indicators; 10/100BASE-T Ethernet port; Green LED indicates link status; Yellow LED indicates Ethernet activity</p> <table border="1" data-bbox="847 688 1380 1081"> <thead> <tr> <th>TYPE</th> <th>PIN</th> <th>SIGNALS</th> </tr> </thead> <tbody> <tr> <td rowspan="8">8- Position RJ-45</td> <td>1</td> <td>TD+</td> </tr> <tr> <td>2</td> <td>TD-</td> </tr> <tr> <td>3</td> <td>RD+</td> </tr> <tr> <td>4</td> <td>Connected to pin 5</td> </tr> <tr> <td>5</td> <td>Connected to pin 4</td> </tr> <tr> <td>6</td> <td>RD-</td> </tr> <tr> <td>7</td> <td>Connected to pin 8</td> </tr> <tr> <td>8</td> <td>Connected to pin 7</td> </tr> </tbody> </table>	TYPE	PIN	SIGNALS	8- Position RJ-45	1	TD+	2	TD-	3	RD+	4	Connected to pin 5	5	Connected to pin 4	6	RD-	7	Connected to pin 8	8	Connected to pin 7
TYPE	PIN	SIGNALS																				
8- Position RJ-45	1	TD+																				
	2	TD-																				
	3	RD+																				
	4	Connected to pin 5																				
	5	Connected to pin 4																				
	6	RD-																				
	7	Connected to pin 8																				
	8	Connected to pin 7																				
2	<p style="text-align: center;">COMPUTER³</p> 	<p>(1) 6-pin RJ-11 female, computer console port; Bidirectional RS-232 up to 115.2 k baud; Hardware and software handshaking support; 2 ft (0.6 m) RJ-11 to DB9F adapter cable included</p> <table border="1" data-bbox="847 1486 1318 1827"> <thead> <tr> <th>PIN</th> <th>DESCRIPTION</th> </tr> </thead> <tbody> <tr> <td>1</td> <td>CTS</td> </tr> <tr> <td>2</td> <td>GND</td> </tr> <tr> <td>3</td> <td>RXD</td> </tr> <tr> <td>4</td> <td>TXD</td> </tr> <tr> <td>5</td> <td>RTS</td> </tr> <tr> <td>6</td> <td>N/C (Not connected)</td> </tr> </tbody> </table>	PIN	DESCRIPTION	1	CTS	2	GND	3	RXD	4	TXD	5	RTS	6	N/C (Not connected)						
PIN	DESCRIPTION																					
1	CTS																					
2	GND																					
3	RXD																					
4	TXD																					
5	RTS																					
6	N/C (Not connected)																					

(Continued on following page)

Connectors, Controls & Indicators (Continued)

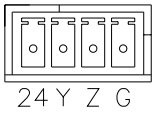
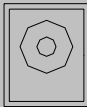
#	CONNECTORS ¹ , CONTROLS & INDICATORS	DESCRIPTION
3	<p>NET⁴</p> 	<p>(1) 3.5 mm detachable terminal block; Cresnet slave port, connects to Cresnet control network</p> <p>Pin 1 (24) Power (24 Volts DC)</p> <p>Pin 2 (Y) Data</p> <p>Pin 3 (Z) Data</p> <p>Pin 4 (G) Ground</p>
4	<p>PWR 12 VDC 0.5A⁴</p> 	<p>(1) 2.5 mm barrel DC power jack, 12 Volt DC power input (power supply included⁵)</p>
5	PWR LED	(1) Green LED, indicates DC power supplied from Cresnet network or 12 Volt DC input
6	NET LED	(1) Yellow LED, indicates communication with the Cresnet system
7	RXD LED	(1) Red LED, indicates data is being received from wireless network devices
8	TXD LED	(1) Red LED, indicates data is being transmitted to wireless network devices
9	ACQUIRE (Button and LED)	(1) Recessed pushbutton with red LED, used to configure the wireless network
10	SETUP (Button and LED)	(1) Recessed pushbutton with red LED, used for touch-settable ID (TSID) and Ethernet auto-discovery
11	ANTENNA	For (included) antenna

1. Interface connector for NET port is provided with the unit.

2. To determine which is pin 1 on the cable, hold the cable so that the end of the eight pin modular jack is facing away from you, with the clip down and copper side up. Pin 1 is on the far left.
3. In the event that modular cables or an RJ-11 to DB9F adapter is not available, the following diagram provides information so that the cable can be fabricated on site. (Alternatively, Crestron cable number STCP-502PC is sold separately.)

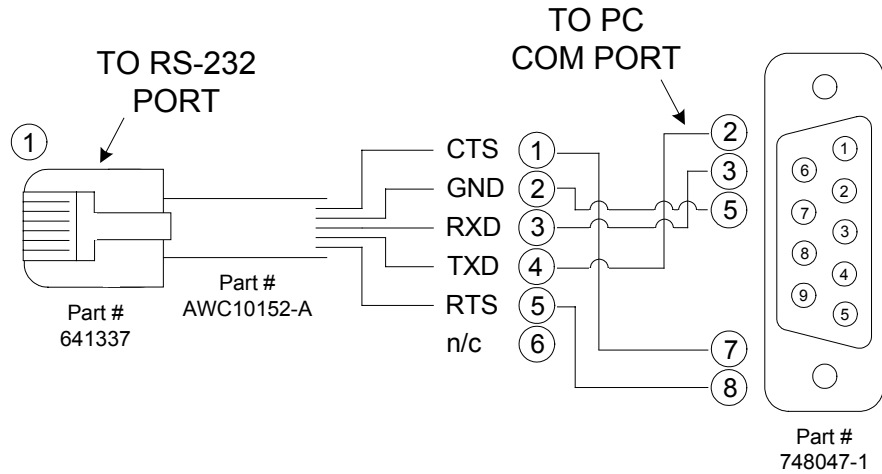

4. The CEN-HPRFGW can be powered via the **12 VDC** jack or the **NET** port. Be sure to use a Crestron approved power supply as another may cause damage.
5. Only the included power supply should be used.

Setup

Network Wiring

When wiring the Cresnet[®] or Ethernet network, consider the following:

- Use Crestron Certified Wire.
- Use Crestron power supplies for Crestron equipment.
- Provide sufficient power to the system.

CAUTION: Insufficient power can lead to unpredictable results or damage to the equipment. Please use the Crestron Power Calculator to help calculate how much power is needed for the system (www.crestron.com/calculators).

Cresnet

For larger networks, use a Cresnet Hub/Repeater (CNXHUB) to maintain signal quality.

For more details, refer to “Check Network Wiring” which starts on page 28.

Ethernet

The CEN-HPRFGW can also use high-speed Ethernet for communications between the device and a control system, computer, digital media server and other IP-based devices.

For information on connecting Ethernet devices in a Crestron system, refer to the latest version of the Crestron e-Control[®] Reference Guide (Doc. 6052), which is available from the Crestron website (www.crestron.com/manuals).

Identity Code

Net ID

The Net ID of the CEN-HPRFGW has been factory set to **2F**. The Net IDs of multiple CEN-HPRFGW devices in the same system must be unique. Net IDs are changed from a personal computer (PC) via the Crestron Toolbox[™] (refer to “Establishing Communication” which starts on page 19).

When setting the Net ID, consider the following:

- The Net ID of each unit must match an ID code specified in the SIMPL[™] Windows[®] program.

- Each network device must have a unique Net ID.

For more details, refer to the Crestron Toolbox help file.

IP ID

The IP ID is set within the CEN-HPRFGW's table using Crestron Toolbox. For information on setting an IP table, refer to the Crestron Toolbox help file. The IP IDs of multiple CEN-HPRFGW devices in the same system must be unique.

When setting the IP ID, consider the following:

- The IP ID of each unit must match an IP ID specified in the SIMPL Windows program.
- Each device using IP to communicate with a control system must have a unique IP ID.

Supplied Hardware

The hardware supplied with the CEN-HPRFGW is listed in the following table.

Supplied Hardware for the CEN-HPRFGW

DESCRIPTION	PART NUMBER	QUANTITY
Metal Mounting Plate	2020635	1
Screw, #04-40 x 3/16"	2007150	2

Installation

Ventilation

To prevent overheating, do not operate this product in an area that exceeds the environmental temperature range listed in the table of specifications. Consider using forced air ventilation and/or incrementing the spacing between units to reduce overheating. Consideration must be given if installed in a closed or multi-unit rack assembly since the operating ambient temperature of the environment may be greater than the room ambient temperature. Contact with thermal insulating materials should be avoided on all sides of the unit.

Feet

Four "feet" are provided with the CEN-HPRFGW to provide stability when the unit is placed on a flat surface. These feet should be attached prior to the hookup procedure.

**Surface
Mounting**

To aid in surface mounting, the CEN-HPRFGW comes with a metal mounting plate.

Using the two included #04-40 x 3/16" screws provided, attach the mounting plate to the bottom of the CEN-HPRFGW as shown in the illustration below.

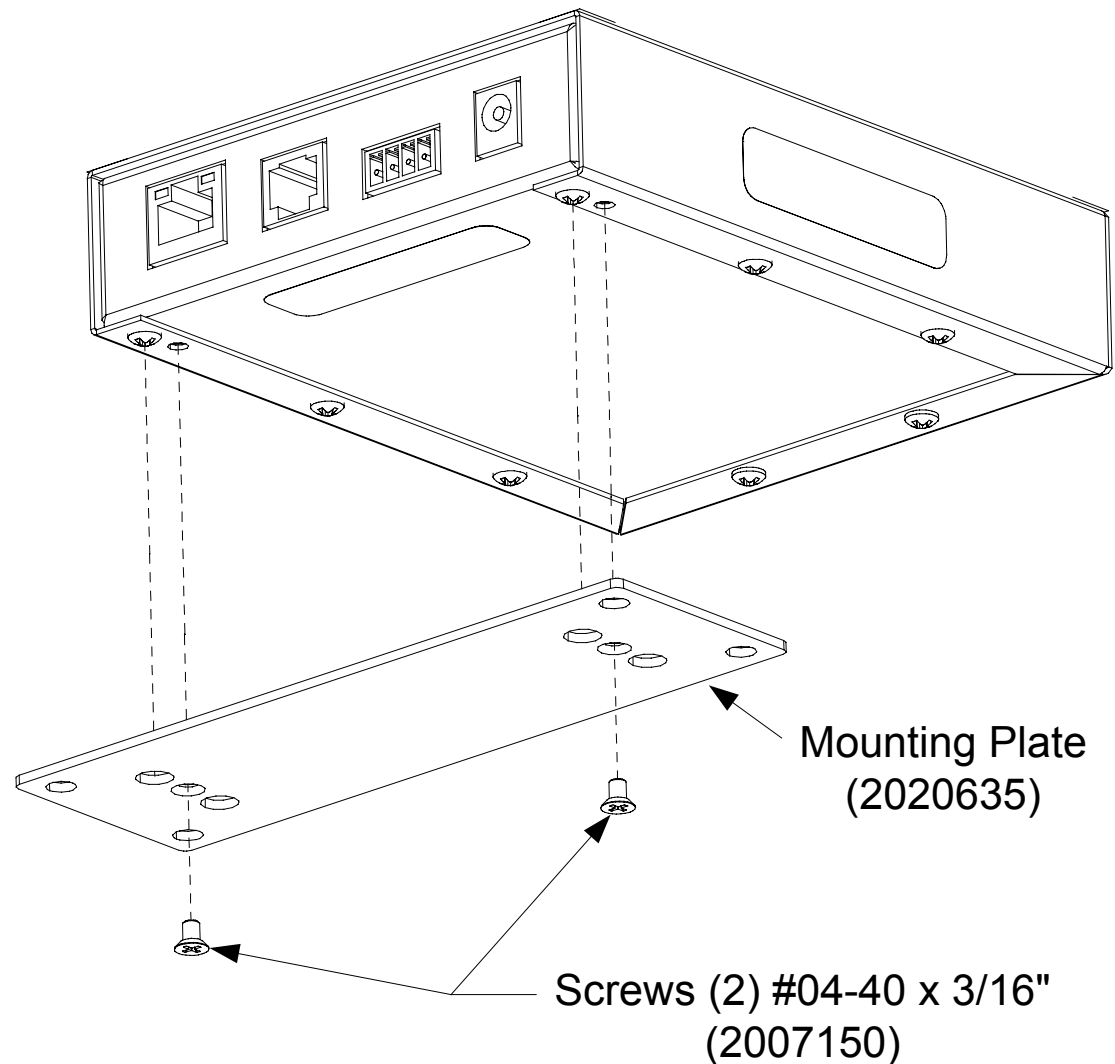
Attaching the Mounting Plate**Placement
Tips**

When installing a CEN-HPRFGW near another CEN-HPRFGW, for optimum performance, keep the following in mind:

- Do not place multiple gateways on the same channel. Refer to “Appendix A: The RF Spectrum” on page 31 for details.

- Gateways on adjacent channels should be at least 12 feet apart.
- Gateways on non-adjacent channels should be at least three feet apart.

When installing a CEN-HPRFGW near a Wi-Fi access point, for optimum performance, keep the following in mind:

- Gateways on RF channels adjacent to operating Wi-Fi channels should be placed at least 12 feet from the nearest Wi-Fi access point.
- Gateways on RF channels that are non-adjacent to Wi-Fi channels should be located at least six feet from the nearest Wi-Fi access point.

For more information on RF channels and their interaction with the Wi-Fi spectrum, refer to “Appendix A: The RF Spectrum” on page 31. For additional information on optimal gateway placement, refer to “Appendix B: Optimum RF Reception Guidelines” which starts on page 32.

Hardware Hookup

Make the necessary connections as called out in the illustration that follows this paragraph. Refer to “Network Wiring” on page 10 before attaching the 4-position terminal block connector. Apply power after all connections have been made.

When making connections to the CEN-HPRFGW, consider the following:

- Use Crestron power supplies for Crestron equipment.
- The included cable cannot be extended.

Hardware Connections for the CEN-HPRFGW (Front View)

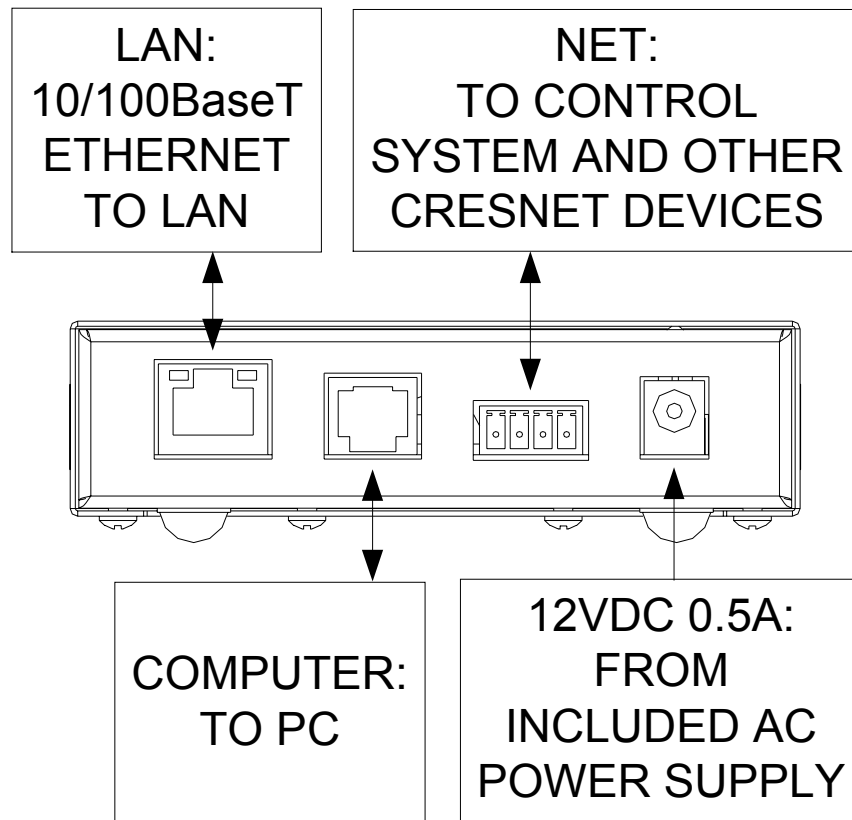

Hardware Connections for the CEN-HPRFGW (Rear View)

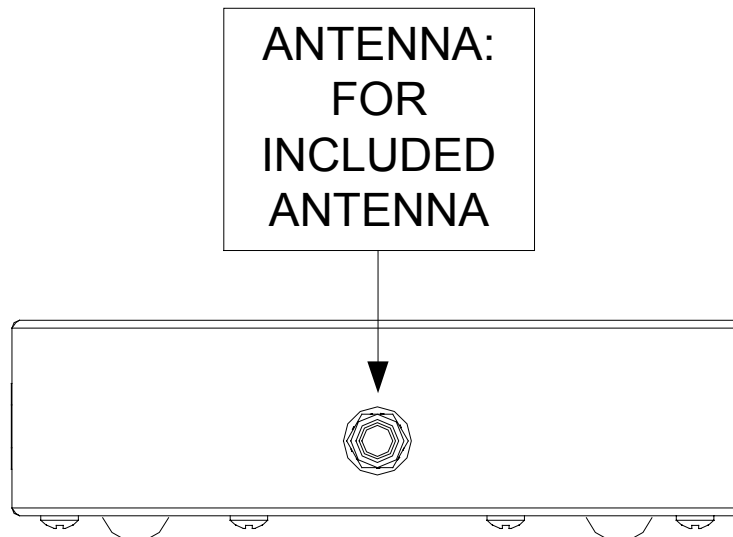

NOTE: Antenna must be attached directly to the antenna connector. It should not be extended with a cable.

Programming Software

Have a question or comment about Crestron software?

Answers to frequently asked questions (FAQs) can be viewed in the Online Help section of the Crestron website. To post a question or view questions you have submitted to Crestron's True Blue Support, log in at <http://support.crestron.com>. First-time users will need to establish a user account.

Earliest Version Software Requirements for the PC

NOTE: Crestron recommends that you use the latest software to take advantage of the most recently released features. The latest software is available from the Crestron website.

Crestron has developed an assortment of Windows[®]-based software tools to develop a Cresnet system. For the minimum recommended software versions, visit the Version Tracker page of the Crestron website (www.crestron.com/versiontracker).

Programming with Crestron SystemBuilder

Crestron SystemBuilder is the easiest method of programming but does not offer as much flexibility as SIMPL Windows. For additional details, download SystemBuilder from the Crestron website and examine the extensive help file.

Programming with SIMPL Windows

NOTE: While SIMPL Windows can be used to program the CEN-HPRFGW, it is recommended to use SystemBuilder for configuring a system.

SIMPL Windows is Crestron's premier software for programming Crestron control systems. It is organized into two separate but equally important "Managers".

Configuration Manager

Configuration Manager is the view where programmers “build” a Crestron control system by selecting hardware from the *Device Library*.

- To incorporate the CEN-HPRFGW into the system, drag the CEN-HPRFGW from the Wireless Receivers | Wireless Receivers (RF) folder of the *Device Library* and drop it in the *System Views*.

Locating the CEN-HPRFGW in the Device Library

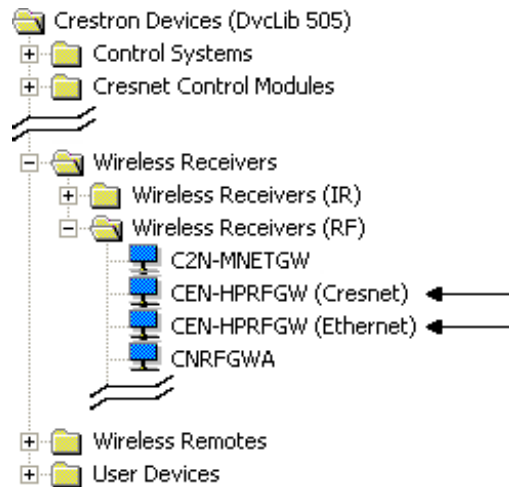

- The system tree of the control system displays the device in the appropriate slot(s) with a default Net ID or IP ID as shown in the following illustration.

NOTE: A single CEN-HPRFGW should be on either Cresnet or Ethernet but not both.

C2Net Device, Slots 8 and 9

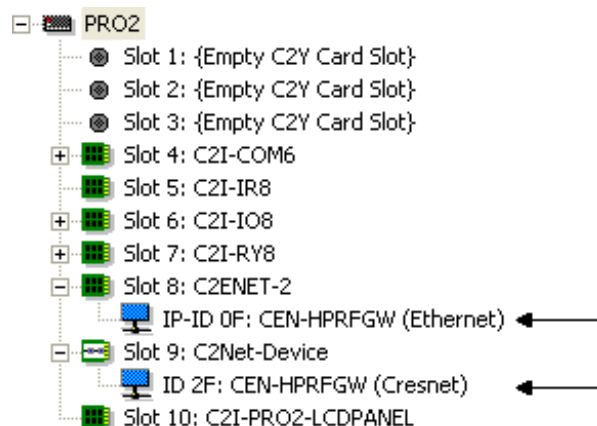

- Additional CEN-HPRFGW devices are assigned different Net ID or IP ID numbers as they are added.

- If necessary, double click a device to open the “Device Settings” window and change the Net ID or IP ID, as shown in the following figure(s).

“CEN-HPRFGW Device Settings (Cresnet)” Window

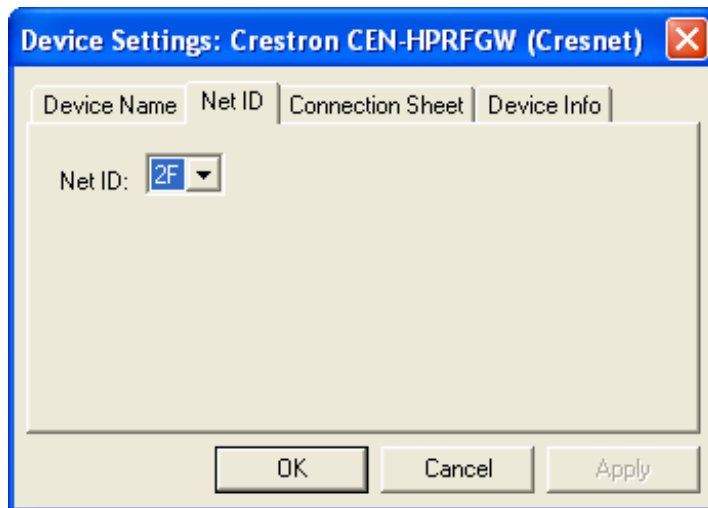

“CEN-HPRFGW Device Settings (Ethernet)” Window

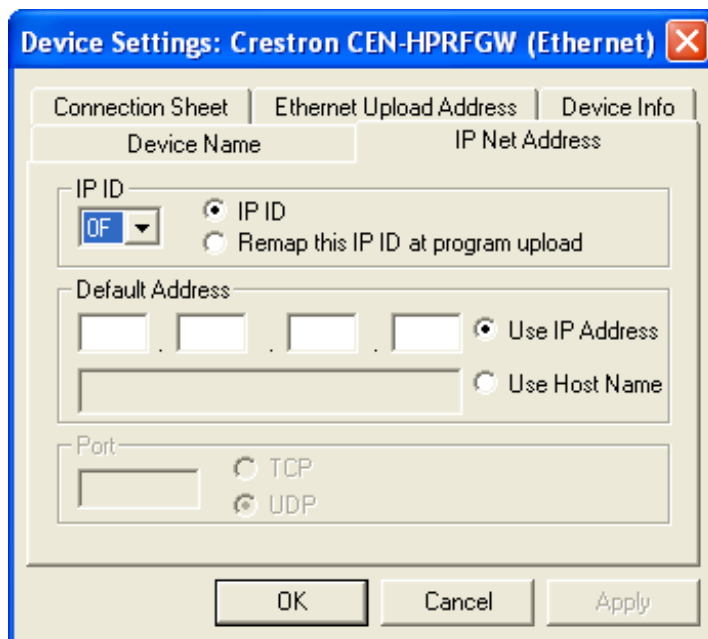

- The ID code specified in the SIMPL Windows program must match the Net ID or IP ID of each unit. Refer to “Identity Code” which starts on page 10.

**Program
Manager**

Program Manager is the view where programmers “program” a Crestron control system by assigning signals to symbols.

The symbol can be viewed by double clicking on the icon or dragging it into *Detail View*. Each signal in the symbol is described in the SIMPL Windows help file (**F1**).

Example Program

An example program for the CEN-HPRFGW is available from the Crestron website (www.crestron.com/exampleprograms).

Uploading and Upgrading

Crestron recommends using the latest programming software and that each device contains the latest firmware to take advantage of the most recently released features. However, before attempting to upload or upgrade it is necessary to establish communication. Once communication has been established, files (for example, programs or firmware) can be transferred to the control system (and/or device). Finally, program checks can be performed (such as changing the device ID or creating an IP table) to ensure proper functioning.

Establishing Communication

Use Crestron Toolbox for communicating with the CEN-HPRFGW; refer to the Crestron Toolbox help file for details. There are three methods of communication.

Direct Serial

NOTE: Required for initial setup of Ethernet parameters.

Direct Serial Communication

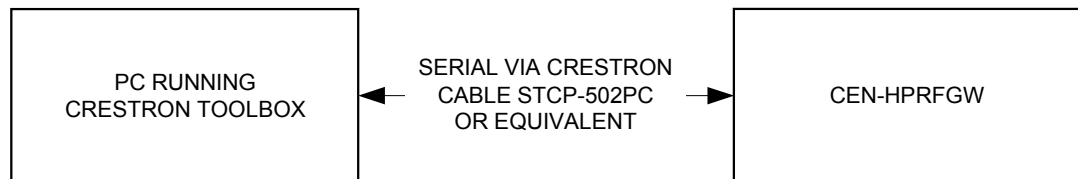

The **COMPUTER** port on the CEN-HPRFGW connects to the serial port on the PC via a serial cable (Crestron STCP-502PC or equivalent):

1. Use the Address Book in Crestron Toolbox to create an entry using the expected serial communication protocol (RS-232, auto-detect baud rate, no parity, 8 data bits, 1 stop bit, XON/XOFF disabled, RTS/CTS disabled).
2. Display the CEN-HPRFGW's "System Info" window (click the  icon); communications are confirmed when the device information is displayed.

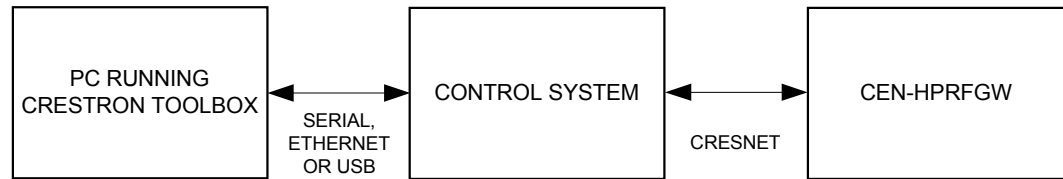
Indirect**Indirect Communication**

CEN-HPRFGW connects to control system via Cresnet:

1. Establish communication between the PC and the control system as described in the latest version of the 2-Series Control Systems Reference Guide (Doc. 6256).
2. Use the Address Book in Crestron Toolbox to create an entry for the CEN-HPRFGW using the expected communication protocol (Indirect). Select the Cresnet ID of the CEN-HPRFGW and the address book entry of the control system that is connected to the CEN-HPRFGW.
3. Display the CEN-HPRFGW's "System Info" window (click the  icon); communications are confirmed when the device information is displayed.

TCP/IP

NOTE: Required for operation with a Crestron control system.

Ethernet Communication

The CEN-HPRFGW connects to PC via Ethernet:

1. Establish serial communication between CEN-HPRFGW and PC.
2. Enter the IP address, IP mask, and default router of the CEN-HPRFGW via the Crestron Toolbox (**Functions | Ethernet Addressing**); otherwise enable DHCP.
3. Confirm Ethernet connections between CEN-HPRFGW and PC. If connecting through a hub or router, use CAT5 straight through cables with 8-pin RJ-45 connectors. Alternatively, use a CAT5

crossover cable to connect the two **LAN** ports directly without using a hub or router.

4. Use the Address Book in Crestron Toolbox to create an entry for the CEN-HPRFGW with the CEN-HPRFGW's TCP/IP communication parameters.
5. Display the "System Info" window (click the  icon) and select the CEN-HPRFGW entry.

Programs and Firmware

Program or firmware files may be distributed from programmers to installers or from Crestron to dealers. Firmware upgrades are available from the Crestron website as new features are developed after product releases. One has the option to upload programs via the programming software or to upload and upgrade via the Crestron Toolbox. For details on uploading and upgrading, refer to the SIMPL Windows help file or the Crestron Toolbox help file.

SIMPL Windows

If a SIMPL Windows program is provided, it can be uploaded to the control system using SIMPL Windows or Crestron Toolbox.

Firmware

Check the Crestron website to find the latest firmware. (New users may be required to register to obtain access to certain areas of the site, including the FTP site.)

Upgrade CEN-HPRFGW firmware via Crestron Toolbox.

1. Establish communication with the CEN-HPRFGW and display the "System Info" window.
2. Select **Functions | Firmware...** to upgrade the CEN-HPRFGW firmware.

Program Checks

Actions that can be performed on the CEN-HPRFGW vary depending on whether it is connected via Cresnet or Ethernet.

Cresnet Connections

For Cresnet connections, using Crestron Toolbox, display the network device tree (**Tools | Network Device Tree**) to show all network devices connected to the control system. Right-click on the CEN-HPRFGW to display actions that can be performed on the CEN-HPRFGW.

Ethernet Connections

For Ethernet connections, display the “System Info window (click the  icon) and select the **Functions** menu to display actions that can be performed on the CEN-HPRFGW.

Be sure to use the Crestron Toolbox to create the CEN-HPRFGW IP table.

1. Select **Functions | IP Table Setup**.
2. Add, modify or delete entries in the IP table. The CEN-HPRFGW can have only one IP table entry.
3. A defined IP table can be saved to a file or sent to the device.

Edit the control system’s IP table to include an entry for the CEN-HPRFGW. The entry should list the CEN-HPRFGW’s IP ID (specified on the CEN-HPRFGW’s IP table) and the internal gateway IP address 127.0.0.1.

Operation

Operating Channel

The operating channel of the CEN-HPRFGW must be set prior to operation using Crestron Toolbox. The CEN-HPRFGW can operate on one of 16 channels. The CEN-HPRFGW can operate on a fixed channel that is set by the installer.

For optimum performance when installing a CEN-HPRFGW in a Wi-Fi environment, do not set the CEN-HPRFGW to a channel within a Wi-Fi channel band. Crestron recommends channel 15 or channel 20.

- Gateway channels 11-14 are within Wi-Fi channel 1 band.
- Gateway channel 15 is adjacent to Wi-Fi channels 1 and 6.
- Gateway channels 16-19 are within Wi-Fi channel 6 band.
- Gateway channel 20 is adjacent to Wi-Fi channels 6 and 11.
- Gateway channels 21-24 are within Wi-Fi channel 11 band.
- Gateway channel 25 is adjacent to Wi-Fi channel 11.
- Gateway channel 26 is neither within or adjacent to any Wi-Fi band.

For detailed information on RF channels, refer to “Appendix A: The RF Spectrum” on page 31.

After establishing communication with the CEN-HPRFGW (refer to “Establishing Communication” which starts on page 19), use Crestron Toolbox to set the operating channel.

RF Channel & RF Power Level

Each gateway can communicate with up to 16 touchpanels on the same channel. Each touchpanel must have an RF channel assignment that matches the RF channel assignment of the gateway.

There are 16 possible channels ranging from 11 to 26.

If two or more gateways are operating in close proximity and experiencing interference problems, you can change the RF power level to reduce signal strength, which may reduce interference.

Settings for RF channel and RF power level are made from a PC via Crestron Toolbox. To access these in Toolbox, select **Functions | High Power RF Gateway...** Refer to the Toolbox Help file and search for “High Power RF Gateway” for more details.

Acquiring the Touchpanel

Touchpanels can communicate with a CEN-HPRFGW only if they have been acquired by that CEN-HPRFGW. The *Acquire* mode can be activated from Crestron Toolbox (recommended) or with the **ACQUIRE** button on the CEN-HPRFGW.

NOTE: To access this in Toolbox, select **Functions | High Power RF Gateway...** Refer to the Toolbox Help file and search for “High Power RF Gateway” for more details.

NOTE: The *Acquire* mode can be activated approximately 15 seconds after applying power to the CEN-HPRFGW.

NOTE: In an environment with multiple gateways, only one gateway should be in the *Acquire* mode at a time.

NOTE: The CEN-HPRFGW must be placed in *Acquire* mode before a touchpanel is placed in the *Acquire* mode.

To acquire a touchpanel via the **ACQUIRE** button on the CEN-HPRFGW:

1. Press **ACQUIRE** on the CEN-HPRFGW to enter the *Acquire* mode. The accompanying LED will illuminate, indicating the unit is ready to link to touchpanels.

NOTE: The *Acquire* mode will automatically deactivate after one hour. This default timeout period can be changed from Toolbox.

2. Place the closest touchpanel in the *Acquire* mode as described in its manual. The device will be automatically acquired by the gateway within two minutes after it enters *Acquire* mode.
3. Repeat step 2 for each touchpanel to be acquired.
4. Press **AQCUIRE** on the CEN-HPRFGW to exit the *Acquire* mode. The LED will turn off.

Problem Solving

Troubleshooting

The following table provides corrective action for possible trouble situations. If further assistance is required, please contact a Crestron customer service representative.

CEN-HPRFGW Troubleshooting

TROUBLE	POSSIBLE CAUSE(S)	CORRECTIVE ACTION
PWR LED does not illuminate.	Incorrect power supply.	Use a Crestron power supply with sufficient power for the network.
	CEN-HPRFGW is not receiving sufficient power.	Use the Crestron Power Calculator to help calculate how much power is needed for the system.
NET LED does not illuminate.	CEN-HPRFGW Net ID is not set to match the Net ID of the SIMPL program.	In Crestron Toolbox, check Functions CresnetID to verify Net ID. Verify SIMPL Windows program ID.
NET LED is on but unit does not communicate with touchpanel.	CEN-HPRFGW is not communicating with network.	Check network cabling for solid connections and correct pinouts.
	CEN-HPRFGW Net ID is not unique; two or more units share the same Net ID.	Verify the Net IDs for all CEN-HPRFGWs are unique when multiple units are used.

(Continued on following page)

CEN-HPRFGW Troubleshooting (Continued)

TROUBLE	POSSIBLE CAUSE(S)	CORRECTIVE ACTION
NET LED is on but unit does not communicate with touchpanel. (Continued)	Touchpanel is set to wrong RF channel.	Refer to the “Setup” section of the guide for the touchpanel to verify that its RF channel is set to match the CEN-HPRFGW channel ID.
	Touchpanel RF ID does not match the RF ID of the SIMPL program.	Use Crestron Toolbox to poll the network. Check the RF ID for the touchpanel, then refer to the “Setup” section of the guide for the touchpanel to set its RF ID to match the RF ID in the SIMPL program.
	Touchpanel is not functioning correctly.	Refer to the “Problem Solving” section of the guide for the touchpanel.
RXD LED does not illuminate when operating the touchpanel or TXD LED illuminates when active but touchpanel does not respond.	Touchpanel is out of range.	Position the touchpanel within operating range or relocate CEN-HPRFGW. Refer to “Specifications” which starts on page 2 for details.

(Continued on following page)

CEN-HPRFGW Troubleshooting (Continued)

TROUBLE	POSSIBLE CAUSE(S)	CORRECTIVE ACTION
Intermittent response from CEN-HPRFGW during communication with touchpanel.	CEN-HPRFGW is in vicinity of metal.	Verify that large amount of metal is not in vicinity of transmission.
	Touchpanel is not functioning correctly.	Refer to the “Problem Solving” section of the guide for the touchpanel.
	Touchpanel is out of range.	Position the touchpanel within operating range or relocate CEN-HPRFGW. Refer to “Specifications” which starts on page 2 for details.
CEN-HPRFGW is not shown on Network Device Tree when polling through Toolbox. Other devices are reported.	Network wiring is incorrect.	Check network cabling for solid connections and correct pinouts.
	CEN-HPRFGW is damaged.	Contact a Crestron customer service representative.
Multiple touchpanels only operate one at a time.	Multiple touchpanels are set to the same RF ID.	Use Crestron Toolbox to poll the network. Check the RF ID for the touchpanel, then refer to the “Setup” section of the guide for the touchpanel to set its RF ID to match the RF ID in the SIMPL program.

Check Network Wiring

Use the Right Wire

In order to ensure optimum performance over the full range of your installation topology, Crestron Certified Wire and only Crestron Certified Wire may be used. Failure to do so may incur additional charges if support is required to identify performance deficiencies because of using improper wire.

Calculate Power

CAUTION: Use only Crestron power supplies for Crestron equipment. Failure to do so could cause equipment damage or void the Crestron warranty.

CAUTION: Provide sufficient power to the system. Insufficient power can lead to unpredictable results or damage to the equipment. Please use the Crestron Power Calculator to help calculate how much power is needed for the system (www.crestron.com/calculators).

When calculating the length of wire for a particular Cresnet run, the wire gauge and the Cresnet power usage of each network unit to be connected must be taken into consideration. Use Crestron Certified Wire only. If Cresnet units are to be daisy-chained on the run, the Cresnet power usage of each network unit to be daisy-chained must be added together to determine the Cresnet power usage of the entire chain. If the unit is home-run from a Crestron system power supply network port, the Cresnet power usage of that unit is the Cresnet power usage of the entire run. The wire gauge and the Cresnet power usage of the run should be used in the following equation to calculate the cable length value on the equation's left side.

Cable Length Equation

$$L < \frac{40,000}{R \times P}$$

Where: L = Length of run (or chain) in feet
 R = 6 Ohms (Crestron Certified Wire: 18 AWG (0.75 MM²))
 or 1.6 Ohms (Cresnet HP: 12 AWG (4 MM²))
 P = Cresnet power usage of entire run (or chain)

Make sure the cable length value is less than the value calculated on the right side of the equation. For example, a Cresnet run using 18 AWG Crestron Certified Wire and drawing 20 watts should not have a length of run more than 333 feet. If Cresnet HP is used for the same run, its length could extend to 1250 feet.

NOTE: All Crestron certified Cresnet wiring must consist of two twisted pairs. One twisted pair is the +24V conductor and the GND conductor and the other twisted pair is the Y conductor and the Z conductor.

Strip and Tin Wire

When daisy-chaining Cresnet units, strip the ends of the wires carefully to avoid nicking the conductors. Twist together the ends of the wires that share a pin on the network connector and tin the twisted connection. Apply solder only to the ends of the twisted wires. Avoid tinning too far up the wires or the end becomes brittle. Insert the tinned connection into the Cresnet connector and tighten the retaining screw. Repeat the procedure for the other three conductors.

Add Hubs

For larger networks (i.e., greater than 28 network devices), it may become necessary to add a Cresnet Hub/Repeater (CNXHUB) to maintain signal quality throughout the network. Also, for networks with lengthy cable runs it may be necessary to add a Hub/Repeater after only 20 devices.

Reference Documents

The latest version of all documents mentioned within the guide can be obtained from the Crestron website (www.crestron.com/manuals). This link will provide a list of product manuals arranged in alphabetical order by model number.

List of Related Reference Documents

DOCUMENT TITLE
2-Series Control Systems Reference Guide
Crestron e-Control Reference Guide

Further Inquiries

If you cannot locate specific information or have questions after reviewing this guide, please take advantage of Crestron's award winning customer service team by calling Crestron at 1-888-CRESTRON [1-888-273-7876].

You can also log onto the online help section of the Crestron website (www.crestron.com/onlinehelp) to ask questions about Crestron products.

First-time users will need to establish a user account to fully benefit from all available features.

Future Updates

As Crestron improves functions, adds new features and extends the capabilities of the CEN-HPRFGW, additional information may be made available as manual updates. These updates are solely electronic and serve as intermediary supplements prior to the release of a complete technical documentation revision.

Check the Crestron website periodically for manual update availability and its relevance. Updates are identified as an “Addendum” in the Download column.

Appendix A: The RF Spectrum

Crestron’s RF network provides 16 RF channels in the 2.4GHz ISM band, specifically IEEE 802.15.4 channels 11 through 26. The 16 channels define the frequencies at which the RF device will communicate.

RF devices on different channels will not communicate or interfere with each other. However, since some of the channels are in the 2.4GHz ISM band (as shown in the following diagram), interference can occur with other devices using this band, such as 802.11b/g Wi-Fi devices, Crestron infiNET™ devices or Zigbee devices, although the differing protocols will not allow a link to be established or data to be transferred. Wireless 2.4GHz telephones and microwave ovens may also cause interference with the network.

IEEE 802.15.4 channel selection (2400 MHz PHY)

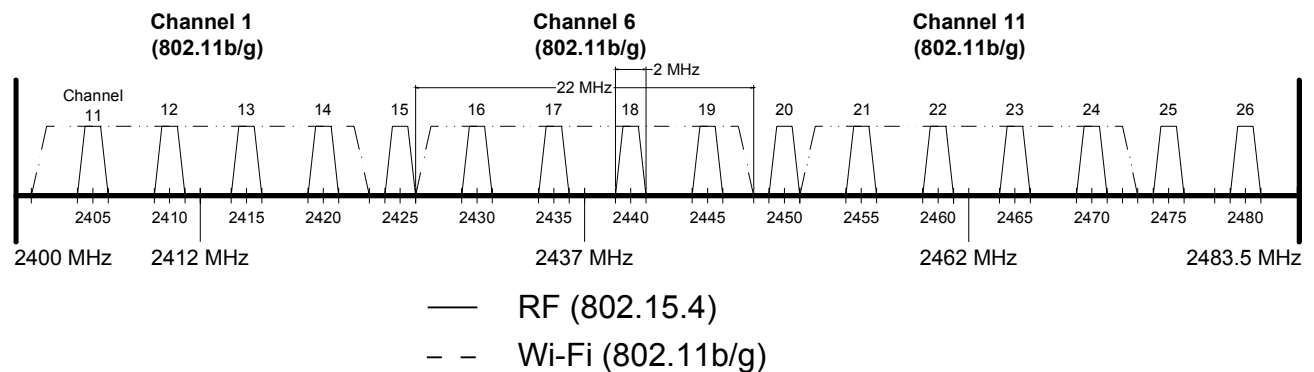

Appendix B: Optimum RF Reception Guidelines

Many factors can affect the reliability of RF communication between an RF gateway and an RF touchpanel. While an effort has been made to determine operating specifications, some specifications are not constant. RF Communication can be limited by several factors including but not limited to EMI (electromagnetic interference), intervening objects, antenna orientation and receiver placement. To obtain maximum reliability and performance, some basic rules for installing RF transceivers are listed below.

Minimize Interference

RF reception range can be hindered by spurious EMI noise that may interfere with or mask the desired frequency, thereby reducing useable range. EMI is generated by any electrical device at various RF noise levels depending on the device. Sources of EMI include computers, video equipment, digital processors, lighting dimmers, lighting ballasts, motors or any large AC source. Every effort should be made to separate any RF transceiver from these sources of RF noise including Audio Visual equipment in racks. If a gateway must be installed in an equipment rack, make sure you have ample separation between the equipment and the gateway.

Gateway Placement

Optimum reception for any RF transceiver is obtained by installing the gateway transceiver in an open area or shelf with a clear line of sight (no obstructions between gateway and receiver). Crestron recommends that the gateway is at least five to six feet high for best results. Avoid placing transceivers or transmitters at a low height or on the ground. Placing RF equipment near metal objects, walls, corners or metal enclosures will compromise RF propagation and reception. Try to avoid installing gateways in equipment racks, service rooms, electrical closets or in rooms other than that which the panel is located.

Antenna Orientation

The antenna orientation on Crestron gateways has considerable effect on range and reliability. The best orientation is unique to each installation. There are three possible antenna orientations:

- Point the antenna horizontally (parallel to the ground)
- Point the antenna vertically.
- Point the antenna at a right angle to the gateway.

Never point the antenna downward as this will decrease range and reliability. Refer to illustration below and those on the following page for examples of the different antenna orientations.

NOTE: RF propagation is best from the sides of the antenna.

Horizontal Orientation

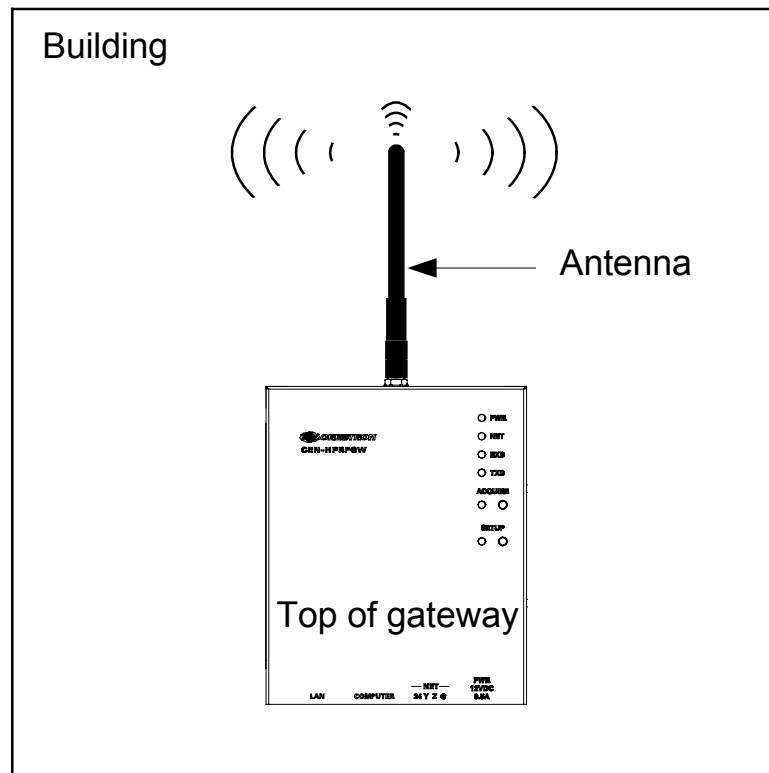

Vertical Orientation

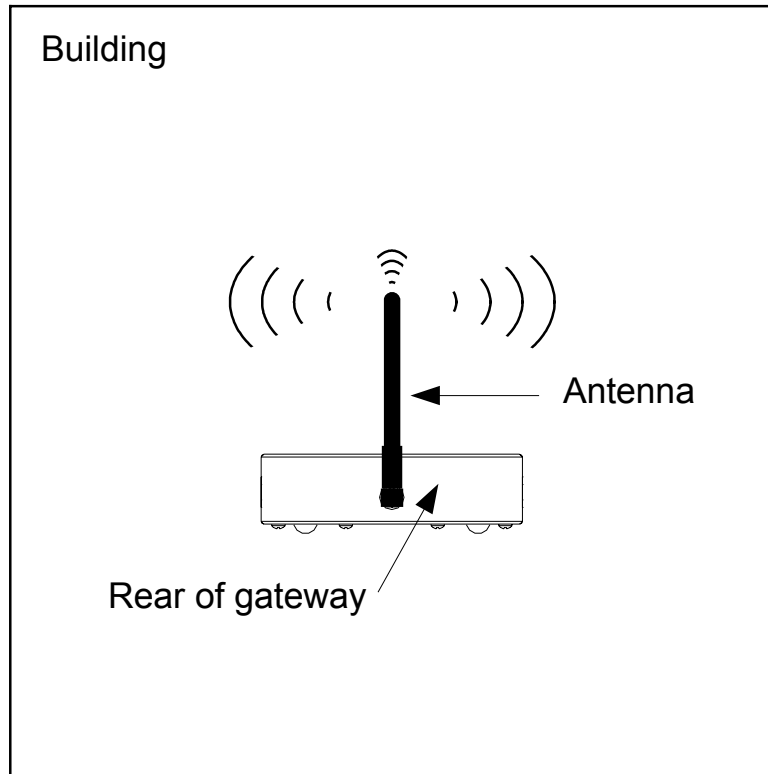

Right Angle Orientation

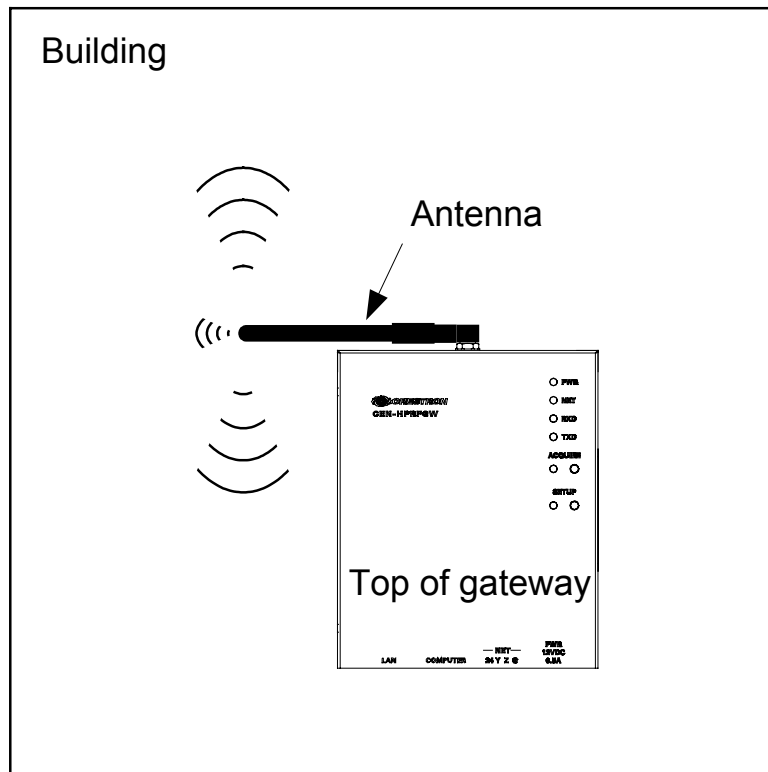

Return and Warranty Policies

Merchandise Returns / Repair Service

1. No merchandise may be returned for credit, exchange or service without prior authorization from CRESTRON. To obtain warranty service for CRESTRON products, contact an authorized CRESTRON dealer. Only authorized CRESTRON dealers may contact the factory and request an RMA (Return Merchandise Authorization) number. Enclose a note specifying the nature of the problem, name and phone number of contact person, RMA number and return address.
2. Products may be returned for credit, exchange or service with a CRESTRON Return Merchandise Authorization (RMA) number. Authorized returns must be shipped freight prepaid to CRESTRON, 6 Volvo Drive, Rockleigh, N.J. or its authorized subsidiaries, with RMA number clearly marked on the outside of all cartons. Shipments arriving freight collect or without an RMA number shall be subject to refusal. CRESTRON reserves the right in its sole and absolute discretion to charge a 15% restocking fee plus shipping costs on any products returned with an RMA.
3. Return freight charges following repair of items under warranty shall be paid by CRESTRON, shipping by standard ground carrier. In the event repairs are found to be non-warranty, return freight costs shall be paid by the purchaser.

CRESTRON Limited Warranty

CRESTRON ELECTRONICS, Inc. warrants its products to be free from manufacturing defects in materials and workmanship under normal use for a period of three (3) years from the date of purchase from CRESTRON, with the following exceptions: disk drives and any other moving or rotating mechanical parts, pan/tilt heads and power supplies are covered for a period of one (1) year; touchscreen display and overlay components are covered for 90 days; batteries and incandescent lamps are not covered.

This warranty extends to products purchased directly from CRESTRON or an authorized CRESTRON dealer. Purchasers should inquire of the dealer regarding the nature and extent of the dealer's warranty, if any.

CRESTRON shall not be liable to honor the terms of this warranty if the product has been used in any application other than that for which it was intended or if it has been subjected to misuse, accidental damage, modification or improper installation procedures. Furthermore, this warranty does not cover any product that has had the serial number altered, defaced or removed.

This warranty shall be the sole and exclusive remedy to the original purchaser. In no event shall CRESTRON be liable for incidental or consequential damages of any kind (property or economic damages inclusive) arising from the sale or use of this equipment. CRESTRON is not liable for any claim made by a third party or made by the purchaser for a third party.

CRESTRON shall, at its option, repair or replace any product found defective, without charge for parts or labor. Repaired or replaced equipment and parts supplied under this warranty shall be covered only by the unexpired portion of the warranty.

Except as expressly set forth in this warranty, CRESTRON makes no other warranties, expressed or implied, nor authorizes any other party to offer any warranty, including any implied warranties of merchantability or fitness for a particular purpose. Any implied warranties that may be imposed by law are limited to the terms of this limited warranty. This warranty statement supersedes all previous warranties.

Trademark Information

All brand names, product names and trademarks are the sole property of their respective owners. Windows is a registered trademark of Microsoft Corporation. Windows95/98/Me/XP/Vista and WindowsNT/2000 are trademarks of Microsoft Corporation.



Crestron Electronics, Inc.
15 Volvo Drive Rockleigh, NJ 07647
Tel: 888.CRESTRON
Fax: 201.767.7576
www.crestron.com

**Operations & Installation Guide – DOC. 6587B
(2018055)**

08.09

Specifications subject to
change without notice.