

# RMK-AMP-X

## Mounting Kit for X-Series Amplifiers

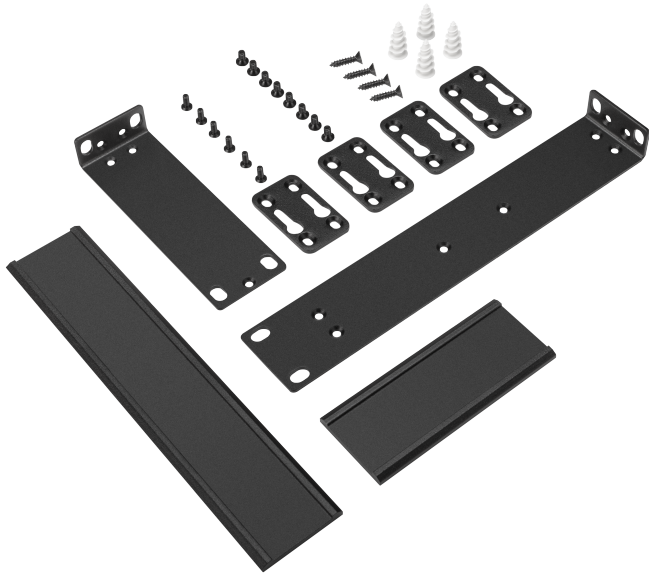

- The RMK-AMP-X is a rack mount kit designed to accommodate [AMP-X300](#), [AMP-X50MP](#), and [AMP-X75](#) amplifiers.
- Provides a secure rack mount solution for placing multiple units together in a rack.
- Facilitates joining several sub-1RU units together to fill out a single rack unit space, or to extend the faceplate of a single sub-1RU unit to fill an entire 1RU space.

The Crestron RMK-AMP-X is a rack mounting kit designed to provide a complete mounting solution for Crestron sub-1RU modular X-Series Amplifiers. The kit includes components for either extending the faceplate of a single sub-1RU unit to fully fill out a 1RU space in the rack, joining several sub-1RU models together to fill out a 1RU width space, or a combination of both (for example, pairing two quarter-rack width AMP-X75's and extending the faceplate out for the remaining half-rack width coverage).

The kit includes joining plates, rack ears, and fascia plates to facilitate any combination of quarter-rack and/or half-rack width X-Series Amplifiers in a 1RU space.

### Specifications

#### Dimension-Rack Ear (Half Width)

Height	0.85 in. (22 mm)
Width	9.50 in. (241 mm)
Depth	1.72 in. (44 mm)

#### Dimension-Rack Ear (Quarter Width)

Height	0.85 in. (22 mm)
Width	5.17 in. (131 mm)
Depth	1.72 in. (44 mm)

#### Dimension-Fascia plate (Half Width)

Height	1.74 in. (44 mm)
Width	8.66 in. (220 mm)

#### Dimension-Fascia plate (Quarter Width)

Height	1.74 in. (44 mm)
Width	4.33 in. (110 mm)

#### Joining Plate

Width	1.96 in. (50 mm)
Depth	1.185 in. (30 mm)

#### Environmental

Temperature	4° to 176° F (-15.5° to 80° C)
Humidity	10% to 95% RH (non-condensing)

#### Weight

1.10 lb (0.45 kg)

#### Model

**RMK-AMP-X**  
Mounting Kit for X-Series Amplifiers

# RMK-AMP-X

## Mounting Kit for X-Series Amplifiers

This product may be purchased from select authorized Crestron dealers and distributors. To find a dealer or distributor, please contact the Crestron sales representative for your area. A list of sales representatives is available online at [www.crestron.com/How-To-Buy/Find-a-Representative](http://www.crestron.com/How-To-Buy/Find-a-Representative) or by calling 855-263-8754.

This product is covered under the Crestron standard limited warranty. Refer to [www.crestron.com/warranty](http://www.crestron.com/warranty) for full details.

The specific patents that cover Crestron products are listed online at [patents.crestron.com](http://patents.crestron.com).

Certain Crestron products contain open source software. For specific information, please visit [www.crestron.com/opensource](http://www.crestron.com/opensource).

Crestron, and the Crestron logo are either trademarks or registered trademarks of Crestron Electronics, Inc. in the United States and/or other countries. Other trademarks, registered trademarks, and trade names may be used in this document to refer to either the entities claiming the marks and names or their products. Crestron disclaims any proprietary interest in the marks and names of others. Crestron is not responsible for errors in typography or photography.

Specifications are subject to change without notice.

©2022 Crestron Electronics, Inc.

Rev 08/04/22

# RMK-AMP-X

## Mounting Kit for X-Series Amplifiers

### Fascia Plate and Rack Ear

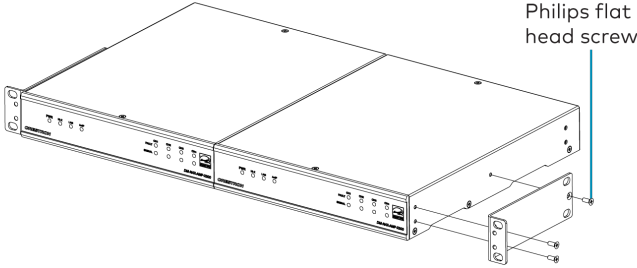
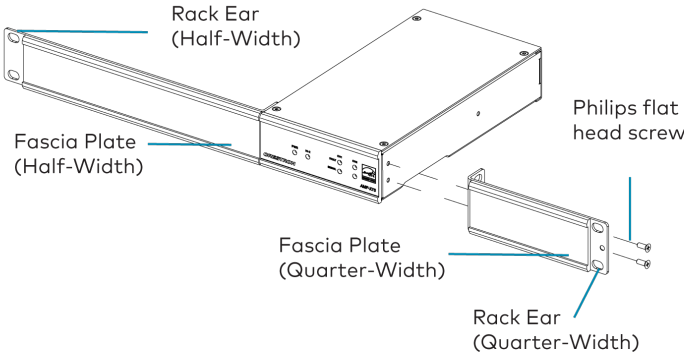
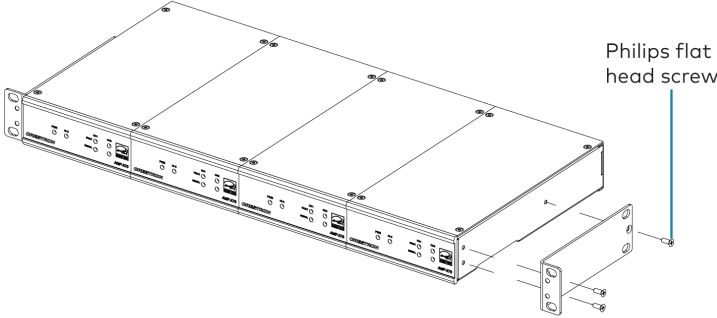
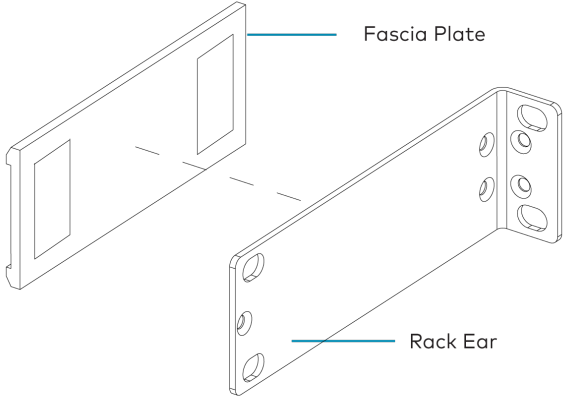

# RMK-AMP-X

## Mounting Kit for X-Series Amplifiers

### Joining Plate

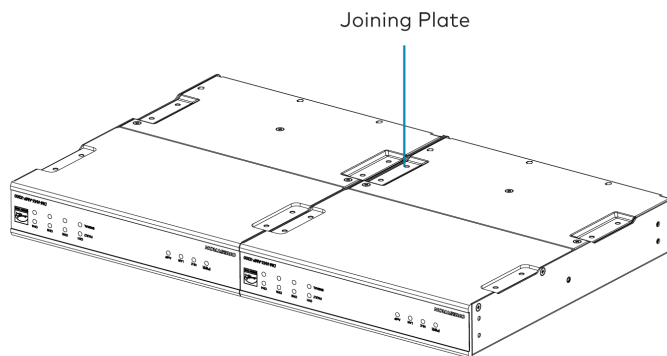
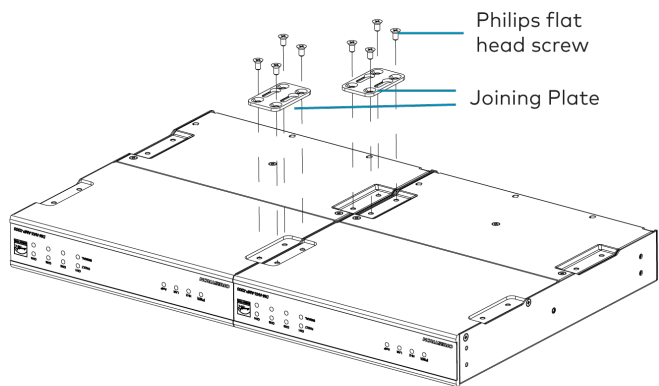
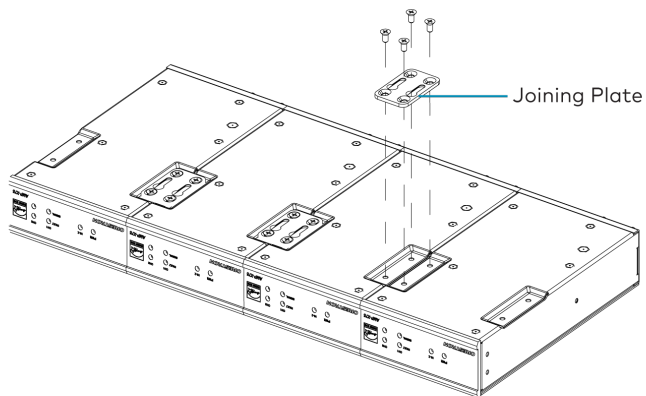
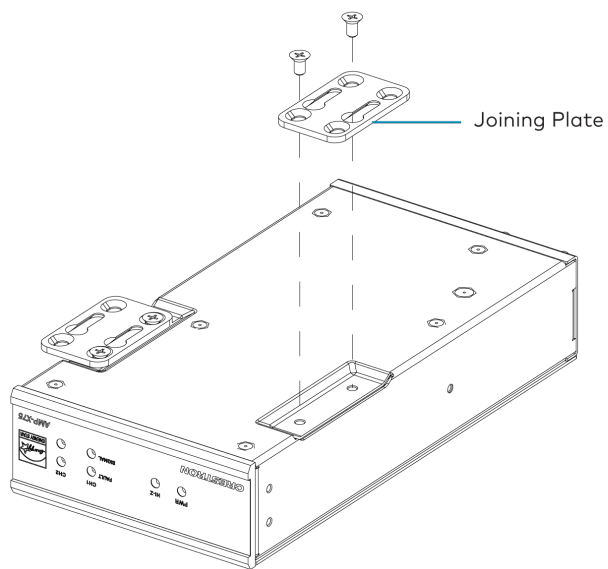

# RMK-AMP-X

## Mounting Kit for X-Series Amplifiers

### Rack Ear (Half-Width)

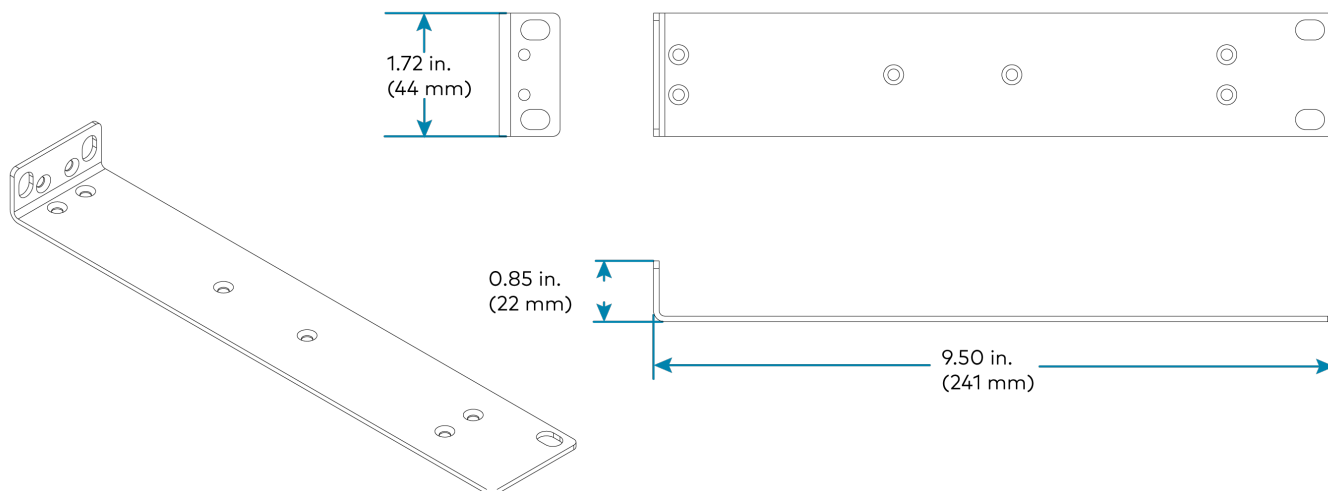

### Rack Ear (Quarter-Width)

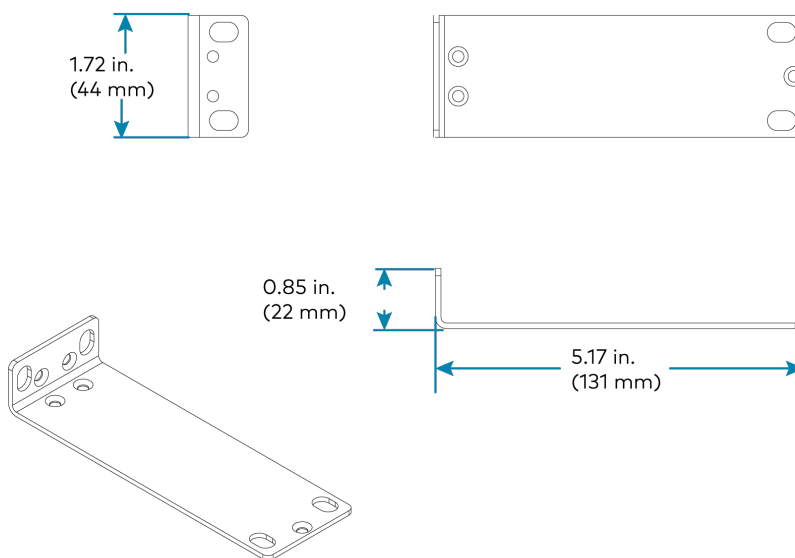

# RMK-AMP-X

## Mounting Kit for X-Series Amplifiers

### Fascia Plate (Half-Width)

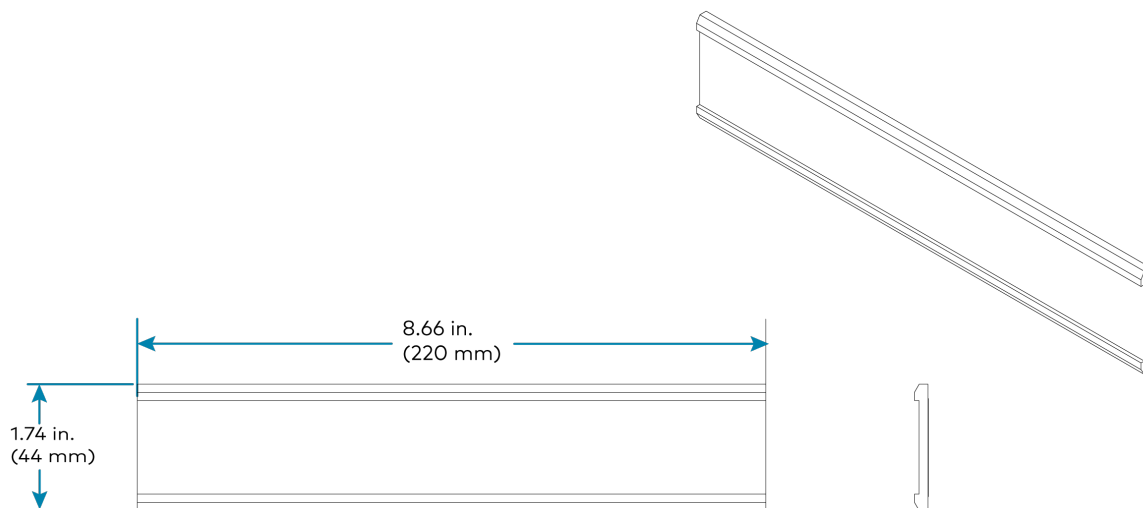

### Fascia Plate (Quarter-Width)

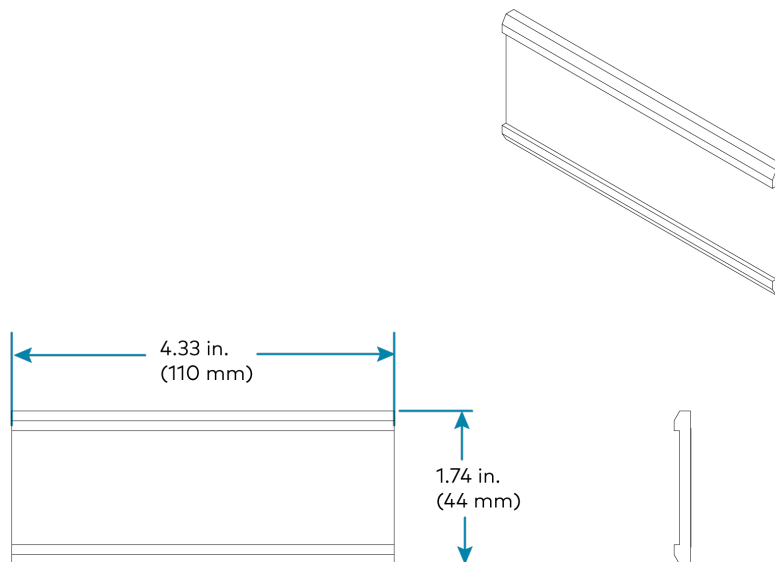

# RMK-AMP-X

## Mounting Kit for X-Series Amplifiers

### Joining Plate

