Introduction

Crestron Green Light® architectural dimming cabinets come pre-configured with GLX architectural dimming and switching modules already installed. The cabinets only require feeding the loads from the breaker panel (provided by others) to the cabinet and wiring the load circuits.

NOTE: This document is written for “Feed-Through (FT)” dimming cabinets. For instructions on wiring “Main Lug” cabinets, refer to the latest version of the GLE-MLO Series Installation Guide (Doc. 6688) which is available from the Crestron® Web site (www.crestron.com/manuals).

Industry Compliance

The products meet the requirements of the following UL and CSA standards as Industrial Control Equipment:

- UL 508, the Standard for Industrial Control Equipment
- CSA C22.2 No. 14-05, the Standard for Industrial Control Equipment for Use in Ordinary Locations

When marked as “EMERGENCY CIRCUITS” the products meet the additional requirements for Emergency Lighting.

- UL 924, the Standard for Emergency Lighting and Power Equipment
- CSA C22.2 No. 141, the Standard for Unit Equipment for Emergency Lighting.



IMPORTANT SAFEGUARDS

When using electrical equipment, basic safety precautions should always be followed including the following:

READ AND FOLLOW ALL SAFETY INSTRUCTIONS.

- a) Do not use outdoors.
- b) Do not mount near gas or electric heaters.
- c) Equipment should be mounted in locations and at heights where it will not readily be subjected to tampering by unauthorized personnel.
- d) The use of accessory equipment not recommended by the manufacturer may cause an unsafe condition.
- e) Do not use this equipment for other than intended use.
- f) All servicing should be performed by qualified service personnel.
- g) If any Emergency Circuits are fed or controlled from this panel, it must be located electrically where fed from a UPS, generator, or other guaranteed source of power during emergency and power outage situations.

SAVE THESE INSTRUCTIONS

Application

The following diagram shows a Crestron Green Light architectural feed-through dimming cabinet in a lighting application that is controlled by a PAC2 system.

Crestron Green Light Architectural Dimming Cabinets in a Typical Lighting Application

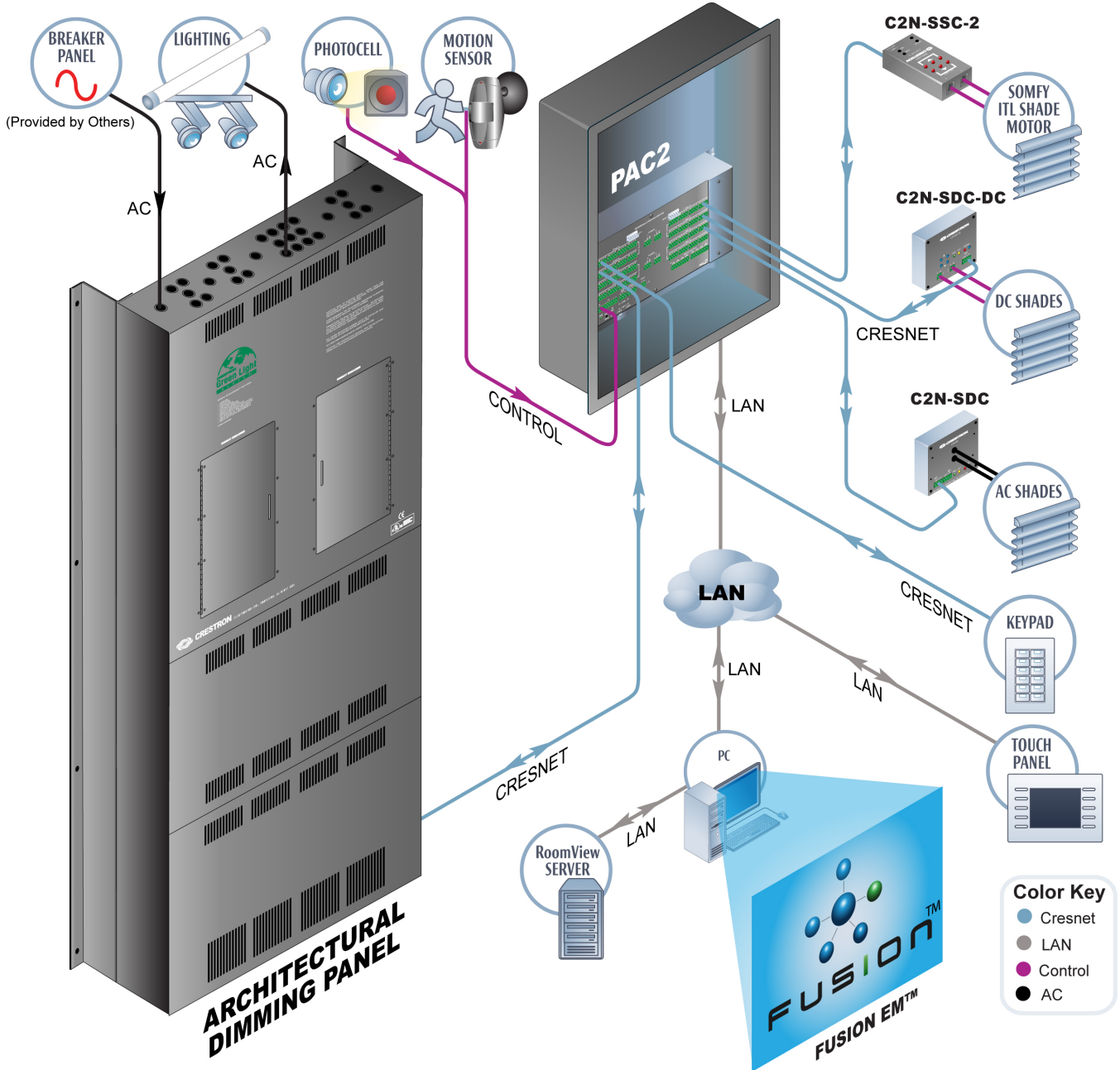

Physical Description

This section shows the exterior and interior dimensions of the Crestron Green Light Architectural “Feed-Through” Dimming cabinet.

External Dimensions of Crestron Green Light Architectural Dimming Cabinets

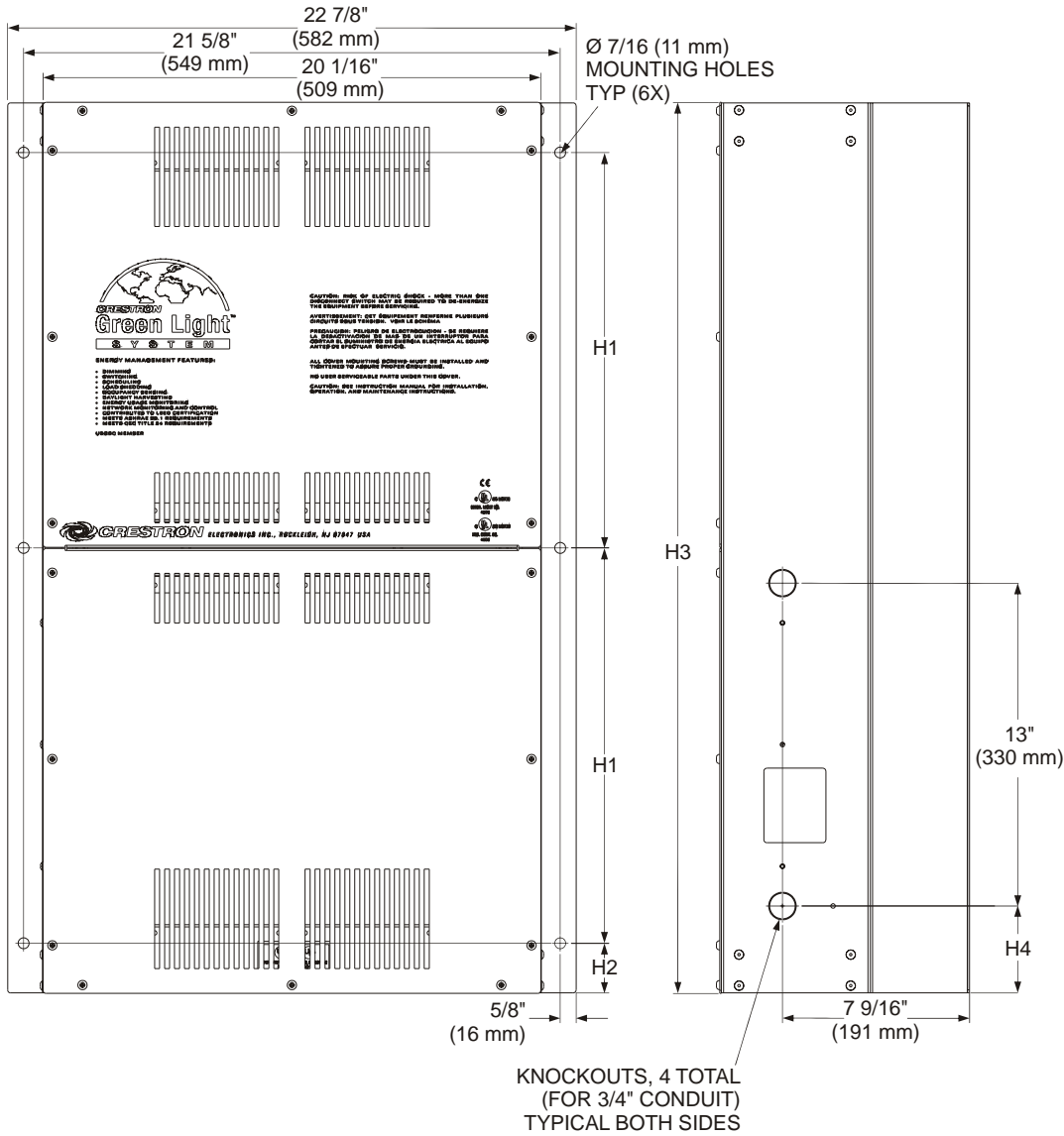

KNOCKOUTS, 4 TOTAL (FOR 3/4" CONDUIT) TYPICAL BOTH SIDES

TECHNICAL KNOCKOUTS, 50 TOTAL, (FOR 3/4" AND 1/2" CONDUIT) TYPICAL TOP AND BOTTOM

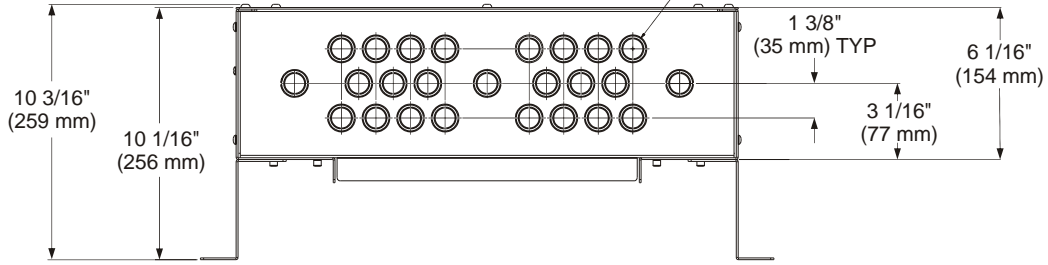

External Dimensions of Crestron Green Light Architectural Dimming Cabinets

DIMENSION	GLE-FT-2X2	GLE-FT-3X2
Module Spaces	4	6
H1	15 15/16" (405 mm)	22 3/8" (568 mm)
H2	2" (51 mm)	5" (127 mm)
H3	35 7/8" (911 mm)	54 3/4" (1.39 m)
H4	3 1/2" (89 mm)	5 3/8" (137 mm)

Installation

Observe the following when installing the cabinet:

- The cabinet must be mounted by a licensed electrician in accordance with all national and local codes. Refer to the diagram below for specific requirements.
- Allow adequate clearance in front of the cover for servicing.
- The cabinet is designed for surface mounting on a wall.
- Cabinets are intended for indoor use only.
- The ambient temperature range should be 32° to 104° F (0° to 40° C). The relative humidity should range from 10% to 90% (non-condensing).

Mounting Location

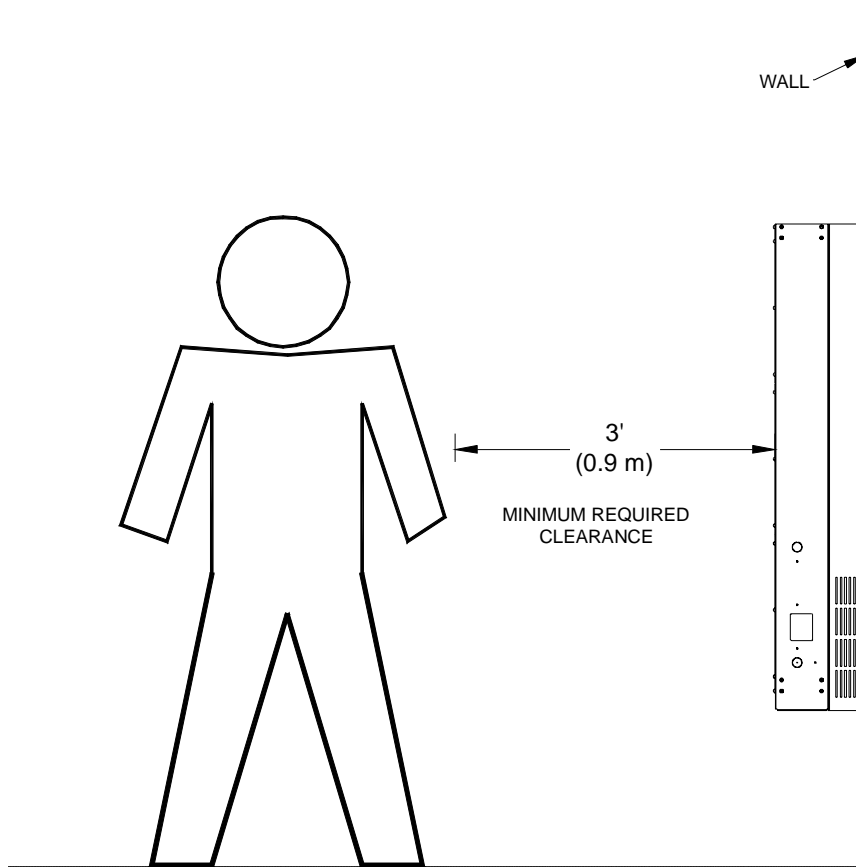

Wiring

NOTE: All wiring must be installed in accordance with all local and national electrical codes.

NOTE: Refer to the torque settings specified on pages 6 and 7.

Crestron Green Light cabinets are shipped with GLX modules installed. The following must be performed after installation:

- Connect feed-through and load wiring to GLX modules (section **A** of the following diagram)
- Connect control wiring (section **B** of the following diagram)

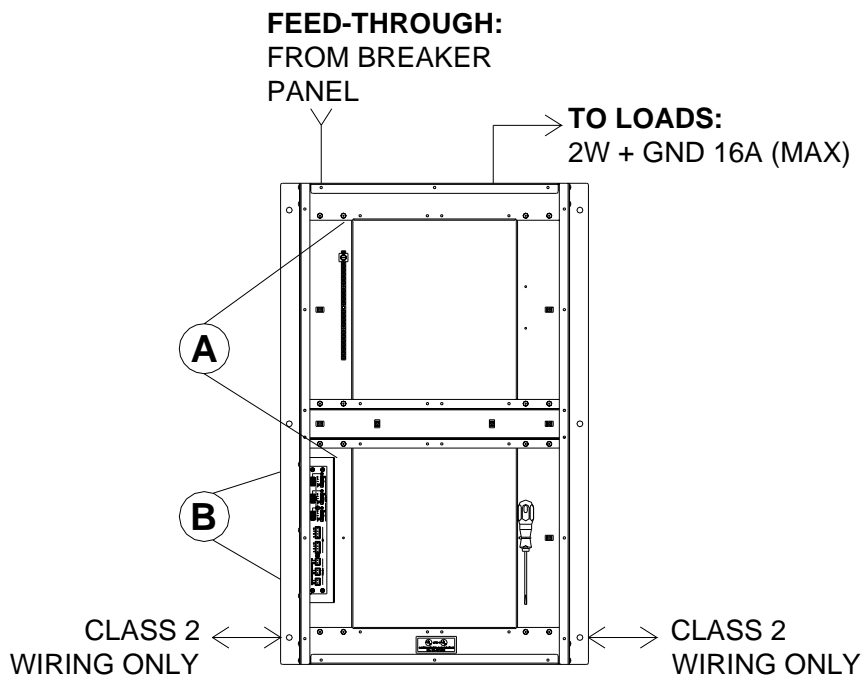

The GLX-DIMFLV8 also requires wiring the terminals for 0-10 VDC control wire. Refer to the following diagram when connecting the dimmable ballast. Each control wire terminal accepts one 12 – 28 AWG wire.

0-10 VDC Control Wiring for GLX-DIMFLV8 Only

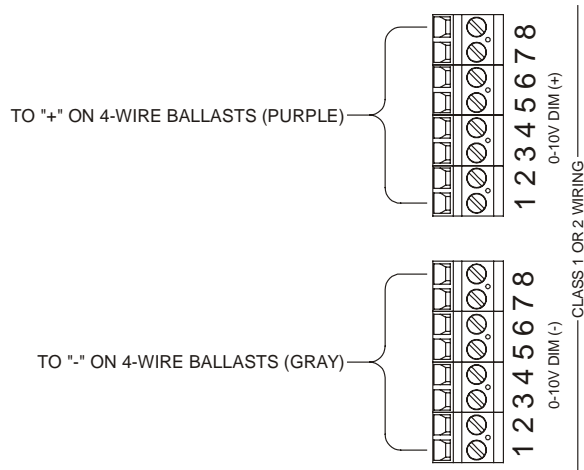

2. Test the circuit for electrical faults by turning on each circuit breaker, checking that the breakers do not trip, and that power is delivered to the proper loads.
3. Turn off the circuit breaker(s) and remove all jumpers.
4. Turn on the circuit breakers.

Control Wiring (Section B)

The bottom left of the cabinet contains Cresnet® connections for interfacing with the rest of the Crestron control system. It also provides an override input which can be tied to devices such as the GLS-PLS-120/277 phase-loss sensor, or other devices that provide a dry contact closure (manual switch, fire alarm relay, etc.).

NOTE: Interface connectors for **NET** (x2), **POWER** (x3), and **OVERRIDE** (x3) ports are provided.

Wire Gauge and Torque Values

TERMINAL	CONNECTOR MAX WIRE RANGE	TORQUE	STRIP LENGTH
NET	26-12 AWG	4.43 lb-in (0.5 Nm)	1/4" (6 mm)
POWER	26-12 AWG	4.43 lb-in (0.5 Nm)	1/4" (6 mm)
OVERRIDE	26-12 AWG	4.43 lb-in (0.5 Nm)	1/4" (6 mm)

Connector Wiring

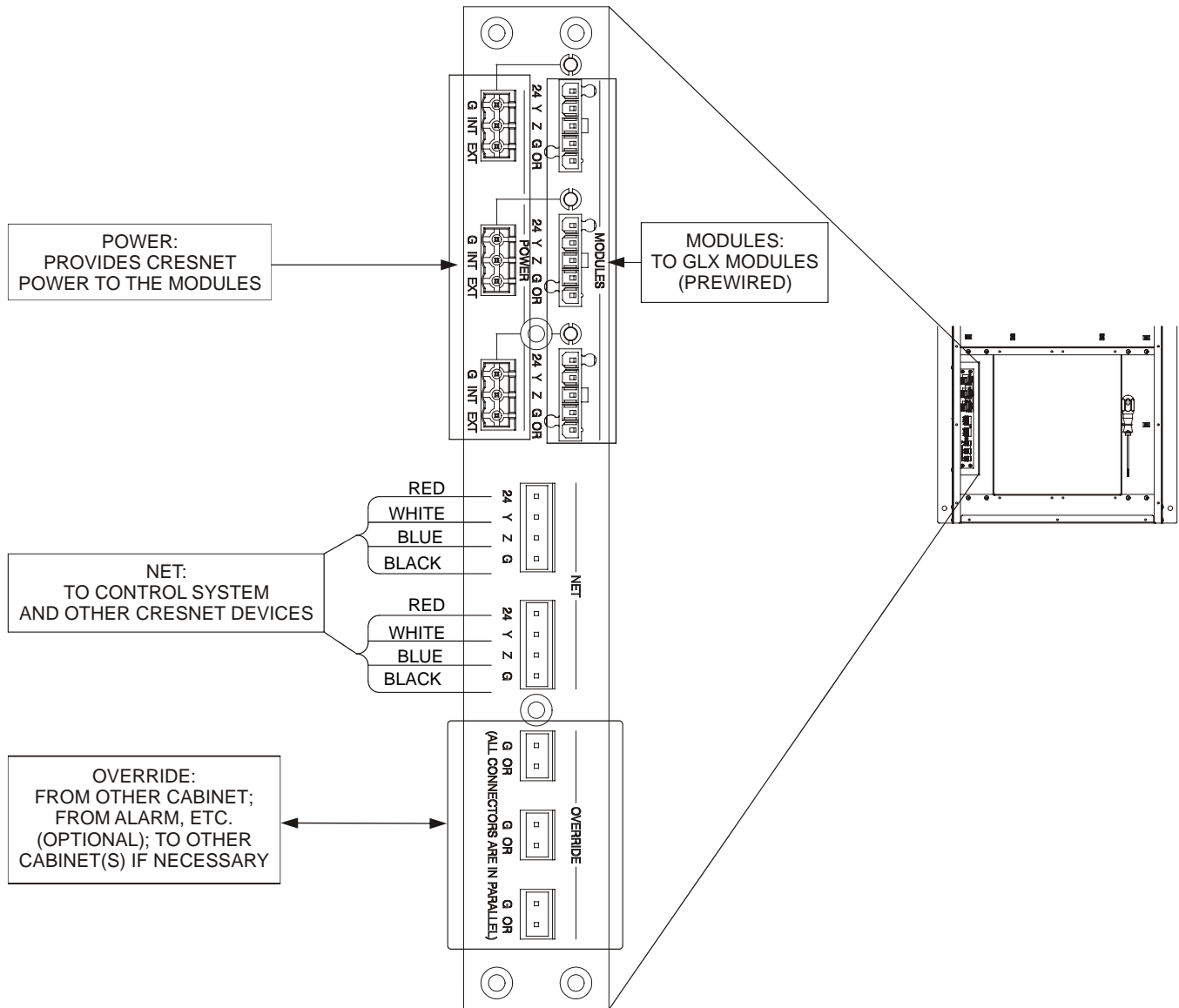

NET Port Wiring

When wiring the supplied **NET** connectors for connection to a Crestron control system or other device on the Cresnet network, use Crestron certified wire such as CRESNET-NP or CRESNET-P (both sold separately).

To ensure optimum performance over the full range of your installation topology, use Crestron certified wire only. Failure to do so may incur additional charges if support is required to identify performance deficiencies because of using improper wire.

When daisy chaining connections between **NET** ports, strip the ends of the wires carefully to avoid nicking the conductors. Twist together the ends of the wires that share a pin on the network connector, insert the connection into the Cresnet connector, and tighten the retaining screw. Repeat the procedure for the other three conductors.

POWER Port Wiring

Each module in a cabinet receives primary power from the AC line connected the module's first line input (circuit 1). Additionally, low voltage (24 VDC) power can also be used to power the module in the event power is disconnected from circuit 1. Low voltage power can be supplied to a module from external devices connected to the **NET** port or a Cresnet power supply connected to the **POWER** port.

NOTE: If AC line power is present on Input 1 and power is connected to either the **NET** port or the **POWER** port in the cabinet, the module will draw power from the AC line.

If using a device connected to the **NET** port to provide low power to the modules, install a jumper from the **INT** pin on the **POWER** connector to the **EXT** pin on the **POWER** connector as shown in the following diagram.

Providing Cresnet Power from a Device Connected to the NET Port

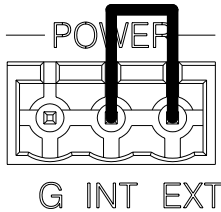

When a lighting module is powered from a device connected to the **NET** port, the module’s **PWR** LED will illuminate.

To power the modules from a Cresnet 24 VDC power supply, connect the external power supply to the **EXT** and **G** pins on the **POWER** connector as shown in the following diagram.

Providing Cresnet Power Externally

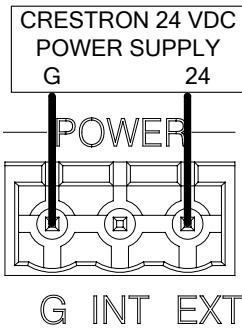

When properly connected and receiving 24 VDC power externally, the green LED next to the **MODULES** port will light.

Under normal operating conditions, each lighting module will draw power from the line voltage on circuit 1. In this case the green **PWR** LED on the module will be lit. If AC power to circuit 1 is interrupted for some reason (e.g., because the breaker trips), the module will automatically draw power from the 24 VDC supply, if available. In this case, the **PWR** LED will flash.

***VERRIDE* Port Wiring**

Low-voltage input devices such as the Crestron GLS-PLS-120/277 phase-loss sensor or any device that provides a dry contact closure can be connected to the supplied **VERRIDE** connector on the bottom of the cabinet.

When a dry contact closure is applied to the **VERRIDE** terminals, all modules in the cabinet will enter *Override* mode. In this mode they will recall their override levels, and will ignore any external commands (e.g., from keypads, touchpanels, or timeclock events) until the override contacts are removed.

For more details, refer to “Override Mode” on page 11.

Testing

Manual Control

A lighting module can be manually controlled from its front panel.

Switch Function

The GLX-HSW8 is a power switching module that can be used to turn loads on and off.

The GLX-DIM6 and the GLX-DIMFLV8 are dimming modules whose outputs can be set to operate as dimmable or non-dimmable outputs. The state of each output can be manually controlled from the front panel.

NOTE: If an output on the GLX-DIM6 does not have a line feed (breaker is tripped or not connected), its associated LED will blink when it is turned on.

To use a module's switch function:

- Ensure the output's mode switch is set to **NON-DIM** (GLX-DIM6 and GLX-DIMFLV8 only). The **DIM** LED will be off.

NOTE: The GLX-DIM6 and GLX-DIMFLV8 ship with all outputs set to **DIM**. Make sure that any switched (non-dim) loads are set to **NON-DIM**.

- Press the ▲ button to turn the output on. The corresponding **ON** LED illuminates and the output state is shown on the **NET ID** display ("On" for on) for two seconds after the button is released.
- Press the ▼ button to turn the output off. The corresponding **ON** LED extinguishes and the output state is shown on the **NET ID** display ("oF" for off) for two seconds after the button is released.

NOTE: The control system program may change the settings if *Override* mode is not enabled.

Dimming Function (GLX-DIM6 and GLX-DIMFLV8 Only)

The lighting level of each of the outputs can be manually controlled from the front panel.

NOTE: If an output on the GLX-DIM6 does not have a line feed (breaker is tripped or not connected), its associated LED will blink when it is turned on.

- Ensure the output's mode switch is set to **DIM** (GLX-DIM6 and GLX-DIMFLV8 only).
- Press and release the ▲ button to turn the output on (100%). The corresponding **ON** and **DIM** LEDs illuminate and the output state is shown on the **NET ID** display ("On" for on) for two seconds after the button is released.
- Press and release the ▼ button to turn the output off. The corresponding **ON** LED extinguishes and the output state is shown on the **NET ID** display ("oF" for off) for two seconds after the button is released.
- To ramp the lighting level up or down, press and hold the output's ▲ or ▼ button. The corresponding **ON** LED illuminates while the load is ON. The **DIM** LED illuminates while the output level is less than 100%. While ramping, the output level is shown on the **NET ID** display as a percentage (01-99, "oF" for off, or "On" for on) and for two seconds after the button is released.

NOTE: The control system program may change the settings if *Override* mode is not enabled.

Override Mode

Override mode overrides the control system program and sets all of the output states to the stored override values. For instructions on saving override settings, refer to “Save Override Settings” below.

To enable *Override* mode, press and release the **OVR** button. The **OVR** LED flashes slowly.

NOTE: If *Override* mode was enabled from an external device (i.e. a contact closure is present on the **OVERRIDE** terminals), the **OVR** LED will flash quickly. Pressing the **OVR** button has no effect.

To disable *Override* mode, press the **OVR** button again. The **OVR** LED extinguishes and the outputs return to the states set by the control system program.

NOTE: If override states have not been stored, the factory default override state is all loads on.

Save Override Settings

The state of each output can be saved as an override setting, which can be automatically recalled when *Override* mode is enabled.

NOTE: The control system program has a setting that can prevent locally changing the override state. If this setting is enabled, the display shows “Er” when trying to save override states. For more information, refer to the SIMPL™ Windows help file.

To save the state of all of the outputs as an override setting, press and hold the **OVR** button for three seconds. The **OVR** LED blinks to indicate the new override settings have been stored.

System Operation and Commissioning

This cabinet has been designed as a component of a programmed Crestron system. System commissioning by an authorized Crestron representative **must** be performed to ensure system operation.

Once the cabinet has been wired and the modules have been tested, contact Crestron at 1-888-CRESTRON [1-888-273-7876] to schedule commissioning.

Problem Solving

Troubleshooting

The following table provides corrective action for possible trouble situations. If further assistance is required, please contact a Crestron customer service representative.

Troubleshooting

TROUBLE	POSSIBLE CAUSE(S)	CORRECTIVE ACTION
Module(s) does not function.	Power not delivered to the module.	If the module is powered internally, verify the circuit breaker connected to the first channel on the module is on and delivering power to the module. If module is powered externally, verify the POWER port is correctly wired and receiving power.
	System commissioning not complete.	Arrange for system commissioning.
Module's PWR LED is flashing.	AC power not present on L1 .	Check that the branch breaker feeding L1 has not tripped. Note unit will continue to function, but will draw power from the backup Cresnet power supply if available.
Unit cannot be taken out of <i>Override</i> mode.	Short (contact closure) exists between G and OVR terminals on any of the OVERRIDE terminals present at bottom of the cabinet.	Determine the reason for the short. Remove or remedy the short (e.g. GLS-PLS-120/277 phase-loss sensor may not have been installed properly, or actual phase-loss has been detected).
Load does not dim.	Mode switch is set to NON-DIM .	Set switch to DIM .
	Module is not wired correctly.	Verify module is wired for dimming.
Fluorescent lamps stay at minimum intensity (0-10V dimmable fluorescents only).	+ or - wires are reversed or shorted.	Verify polarity of + and - wires at ballasts and GLX-DIMFLV8. Check for shorts.
Fluorescent lamps stay at maximum intensity (0-10V dimmable fluorescents only).	+ or - wires are not connected.	Verify polarity of + and - wires at ballasts and GLX-DIMFLV8. Check that there are no open connections.

Further Inquiries

If you cannot locate specific information or have questions after reviewing this guide, please take advantage of Crestron's award winning customer service team by calling Crestron at 1-888-CRESTRON [1-888-273-7876]. For assistance in your region, please refer to the Crestron Web site (www.crestron.com) for a listing of Crestron worldwide offices.

You can also log onto the online help section of the Crestron Web site (www.crestron.com/onlinehelp) to ask questions about Crestron products. First-time users will need to establish a user account to fully benefit from all available features.

Appendix A: Setting Module Net IDs

The following procedure will normally be performed by an authorized Crestron representative as part of the System Commissioning phase. For system wiring and basic testing as described on pages 5 and 10, it is not necessary to perform this step. Only perform this step if instructed by an authorized Crestron representative, or when replacing modules on a system that have already been commissioned (in the latter case, the Net ID should be set to match the Net ID of the module being replaced).

The Net ID of each module in the cabinet is displayed on the module during normal operation and can be changed from the front panel of each module. The Net IDs of each module in the system must be unique.

To set the Net ID using the front panel:

1. Press the recessed **SETUP** button to enter *Setup* mode. The **SETUP** LED illuminates.
2. As shown in the following diagram, press the left button under the **NET ID** display to change the left digit of the Net ID or press the right button under the **NET ID** display to change the right digit of the Net ID number.

Changing the Net ID

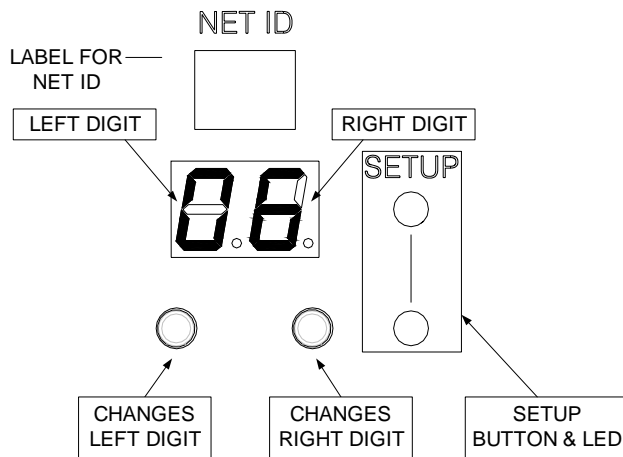

3. When the desired Net ID is displayed, press **SETUP** button to exit *Setup* mode. The **SETUP** LED extinguishes.

If the **SETUP** button is not pressed, *Setup* mode will time out after one minute activity and the Net ID will revert back to its original value.

Appendix B: Module Specifications

Specifications for the GLX modules are listed in the following table.

GLX Module Specifications

SPECIFICATION	GLX-DIM6	GLX-HSW8	GLX-DIMFLV8
Description	6 Channel Dimming/Switching Module	8 Channel High-Inrush Switch Module	8 Channel 0-10V Fluorescent Dimmer Module
Number of Outputs	6	8	8
Cresnet Power Usage ¹	9 Watts	5 Watts	5 Watts
Input Voltage	100 – 277 VAC 50/60 Hz	100 – 277 VAC 50/60 Hz	100 – 277 VAC 50/60 Hz
Supported Load Types	Incandescent, magnetic low voltage (MLV), electronic low voltage (ELV), neon/cold cathode, fluorescent ballast	Incandescent, magnetic low voltage (MLV), electronic low voltage (ELV), neon/cold cathode, fluorescent ballast, HID, motor	<p>Dimmable Loads: 0-10 VDC dimmable fluorescent ballasts (i.e. Advance Mark 7 or other ballasts that comply with the specifications for control by DC voltage in ANSI C82.11:2002 and IEC60929:2006)</p> <p>Non-Dim Loads: Incandescent, HID, magnetic low voltage (MLV), electronic low voltage (ELV), neon/cold cathode, and fluorescent ballasts, motor</p>
Maximum Load			
Lighting	16 A per output	16 A per output	16 A per output
Motor	N/A	½ HP @ 120V 1 HP @ 230V 1 HP @ 277V	½ HP @ 120V 1 HP @ 230V 1 HP @ 277V
Environmental			
Temperature	32° to 104° F (0° to 40° C)	32° to 104° F (0° to 40° C)	32° to 104° F (0° to 40° C)
Humidity	10% to 90% RH (non-condensing)	10% to 90% RH (non-condensing)	10% to 90% RH (non-condensing)
Heat Dissipation ²	550 BTU/Hr	112 BTU/Hr	116 BTU/Hr

1. Power usage will be zero whenever AC power is present on circuit 1 on the module. Use of Cresnet power is optional.
2. Assuming all channels in use with maximum permitted load on every channel.

Return and Warranty Policies

Merchandise Returns / Repair Service

1. No merchandise may be returned for credit, exchange or service without prior authorization from CRESTRON. To obtain warranty service for CRESTRON products, contact an authorized CRESTRON dealer. Only authorized CRESTRON dealers may contact the factory and request an RMA (Return Merchandise Authorization) number. Enclose a note specifying the nature of the problem, name and phone number of contact person, RMA number and return address.
2. Products may be returned for credit, exchange or service with a CRESTRON Return Merchandise Authorization (RMA) number. Authorized returns must be shipped freight prepaid to CRESTRON, 6 Volvo Drive, Rockleigh, N.J. or its authorized subsidiaries, with RMA number clearly marked on the outside of all cartons. Shipments arriving freight collect or without an RMA number shall be subject to refusal. CRESTRON reserves the right in its sole and absolute discretion to charge a 15% restocking fee plus shipping costs on any products returned with an RMA.
3. Return freight charges following repair of items under warranty shall be paid by CRESTRON, shipping by standard ground carrier. In the event repairs are found to be non-warranty, return freight costs shall be paid by the purchaser.

CRESTRON Limited Warranty

CRESTRON ELECTRONICS, Inc. warrants its products to be free from manufacturing defects in materials and workmanship under normal use for a period of three (3) years from the date of purchase from CRESTRON, with the following exceptions: disk drives and any other moving or rotating mechanical parts, pan/tilt heads and power supplies are covered for a period of one (1) year; touchscreen display and overlay components are covered for 90 days; batteries and incandescent lamps are not covered.

This warranty extends to products purchased directly from CRESTRON or an authorized CRESTRON dealer. Purchasers should inquire of the dealer regarding the nature and extent of the dealer's warranty, if any.

CRESTRON shall not be liable to honor the terms of this warranty if the product has been used in any application other than that for which it was intended or if it has been subjected to misuse, accidental damage, modification or improper installation procedures. Furthermore, this warranty does not cover any product that has had the serial number altered, defaced or removed.

This warranty shall be the sole and exclusive remedy to the original purchaser. In no event shall CRESTRON be liable for incidental or consequential damages of any kind (property or economic damages inclusive) arising from the sale or use of this equipment. CRESTRON is not liable for any claim made by a third party or made by the purchaser for a third party.

CRESTRON shall, at its option, repair or replace any product found defective, without charge for parts or labor. Repaired or replaced equipment and parts supplied under this warranty shall be covered only by the unexpired portion of the warranty.

Except as expressly set forth in this warranty, CRESTRON makes no other warranties, expressed or implied, nor authorizes any other party to offer any warranty, including any implied warranties of merchantability or fitness for a particular purpose. Any implied warranties that may be imposed by law are limited to the terms of this limited warranty. This warranty statement supersedes all previous warranties.

Crestron, the Crestron logo, Cresnet, Crestron Green Light, Fusion, Fusion EM, and SIMPL Windows are trademarks or registered trademarks of Crestron Electronics, Inc. in the United States and other countries. Other trademarks, registered trademarks and trade names may be used in this document to refer to either the entities claiming the marks and names or their products. Crestron disclaims any proprietary interest in the marks and names of others.

©2011 Crestron Electronics, Inc.

This page is intentionally left blank.