

Crestron **TPS-VIDL**
Video Card for TPS/Lectern Panel

Operations & Installation Guide

Contents

Video Card for TPS/Lectern Panel: TPS-VIDL	1
Description	1
Functional Description	1
Physical Description	1
Leading Specifications	2
Connector Specifications	3
Installation and Hookup	3
Problem Solving	8
Troubleshooting	8
Further Inquiries	8
Return and Warranty Policies	9
Merchandise Returns / Repair Service	9
CRESTRON Limited Warranty	9

Video Card for TPS/Lectern Panel: TPS-VIDL

Description

Functional Description

The TPS-VIDL video card is an optional feature designed for Crestron's wall/ lectern mounted TPS-5000L and TPS-6000L touchpanels and the TPS-TPI touchpanel interface. The card is a video digitizer that allows television (TV) National Television System Committee (NTSC) or Phase Alternating Line (PAL) video to be displayed on the touchpanel. Composite or S-Video formats are supported and the TV video can be displayed in a window or full screen.

NOTE: A video window object must reside on a page within the uploaded VT Pro-e touchpanel project and the TPS-VIDL must be installed into the proper expansion slot of the TPS-5000L, TPS-6000L, or TPS-TPI in order for the TV video to be displayed. For details regarding video window objects, refer to the VT Pro-e help file.

Physical Description

The TPS-VIDL card, shown below and on the next page, is a printed circuit board (PCB) designed to be installed into a specific expansion slot in the touchpanel (or interface). The card contains a 60-pin connector that attaches directly to the motherboard. TV video access is through two BNC connectors and a 6-pin port that are permanently attached to the TPS-VIDL card. The connectors and port (individually labeled in the **NTSC/PAL INPUT** section of the touchpanel) are accessible through the connector panel at the rear of the case. The card is secured to the motherboard with four attached knurled mounting screws.

TPS-VIDL Side View

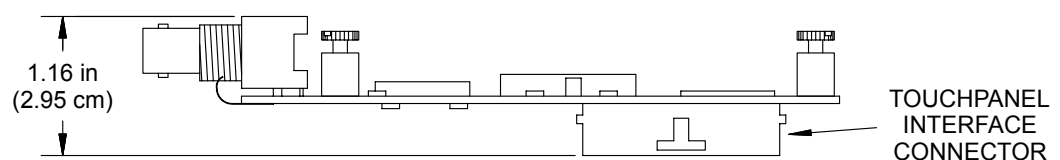

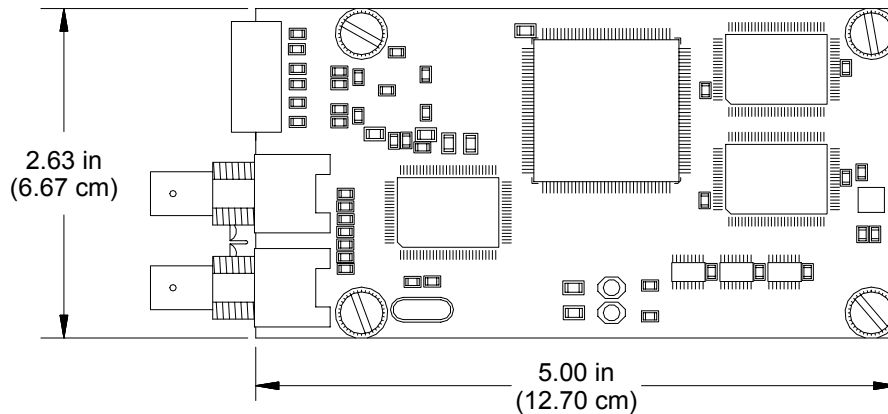
TPS-VIDL Top View

Leading Specifications

The table below provides a summary of leading specifications for the TPS-VIDL. Dimensions and weight are rounded to the nearest hundredth unit.

Leading Specifications of the TPS-VIDL

SPECIFICATION	DETAILS
Power Requirements	24VDC Cresnet power, load factor of 8 Watts.
Video Types	NTSC or PAL
Video Formats	Composite or S-Video
Video Format Detection	Within 4-seconds.
SIMPL™ Windows®	Version 1.40.07 or later ¹ with the addition of smwlib89.exe and smwlib89.txt.
CNMXSX-AV/Pro Update File	Version 51011X or later. ²
CNRACKX/-DP Update File	Version 51011W or later. ²
Dimensions & Weight	Height: 1.16 in (2.95 cm) Width: 2.63 in (6.67 cm) Depth: 5.00 in (12.70 cm) Weight: 3.20 oz (0.09 kg)

1 The latest software version can be obtained from the Downloads page (SIMPLWIN Library) of Crestron's website (www.crestron.com). New users are required to register in order to obtain access to the FTP site.

2 Filenames for update files have a UPZ extension and can be obtained from the Downloads page (OPSYS Library) of Crestron's website.

As of the date of manufacture, this unit has been tested and found to comply with specifications for CE marking.



NOTE: This device complies with part 15 of the FCC rules. Operation is subject to the following two conditions: (1) this device may not cause harmful interference, and (2) this device must accept any interference received, including interference that may cause undesired operation.

Connector Specifications

Connector Specifications of the TPS-VIDL

PORT	TYPE	SIGNAL(S)
Touchpanel Interface	60-pin connector	Various
C +	6-pin connector, 3.5mm	S-Video chrominance input #1
C -	6-pin connector, 3.5mm	S-Video chrominance return
C S	6-pin connector, 3.5mm	S-Video chrominance shield
Y +	6-pin connector, 3.5mm	S-Video luminance input or composite input #1
Y -	6-pin connector, 3.5mm	S-Video luminance return
Y S	6-pin connector, 3.5mm	S-Video luminance shield
C	BNC	S-Video chrominance (color information) input #2
COMP / Y	BNC	Composite video or S-Video luminance (brightness) input #2

Installation and Hookup

The TPS-VIDL is designed to be installed into a specific expansion slot in the TPS-5000L and TPS-6000L touchpanel and the TPS-TPI touchpanel interface. The tools required for installation are a grounding strap (or grounded workstation), #1 Phillips screwdriver, #1 Phillips 1/4-inch hex bit and an inch-pound torque driver.

CAUTION: The TPS-VIDL and the touchpanel contain electrostatic sensitive devices (ESDs); observe precautions for handling ESDs to avoid damaging the card and/or the touchpanel.

NOTE: The diagrams in this procedure show a TPS-6000L touchpanel but the steps for the TPS-5000L and TPS-TPI are identical. This procedure pertains to a touchpanel or interface that is **NOT** installed into a wall or lectern. If already installed, refer to the latest revision of the TPS-5000L, TPS-6000L, or TPS-TPI Operations & Installation Guide (Doc. 5825, 5783, or 5855, respectively) or, if applicable, BB-5000 or BB-6000 Installation Guide (Doc. 5826 or 5827). Disconnect power and perform the installation procedure in reverse to remove the touchpanel or interface. The latest software version of the Operations & Installation Guide can be obtained from the Downloads page (MANUAL Library) of Crestron's website (www.crestron.com). New users are required to register in order to obtain access to the FTP site.

1. To prevent scratching of the screen (TPS-TPI excluded), place the touchpanel face-down onto a padded surface.

2. Refer to the diagram below. Using a #1 Phillips screwdriver, loosen and remove the **10** screws that secure the touchpanel rear cover.

Remove Touchpanel Rear Cover Screws

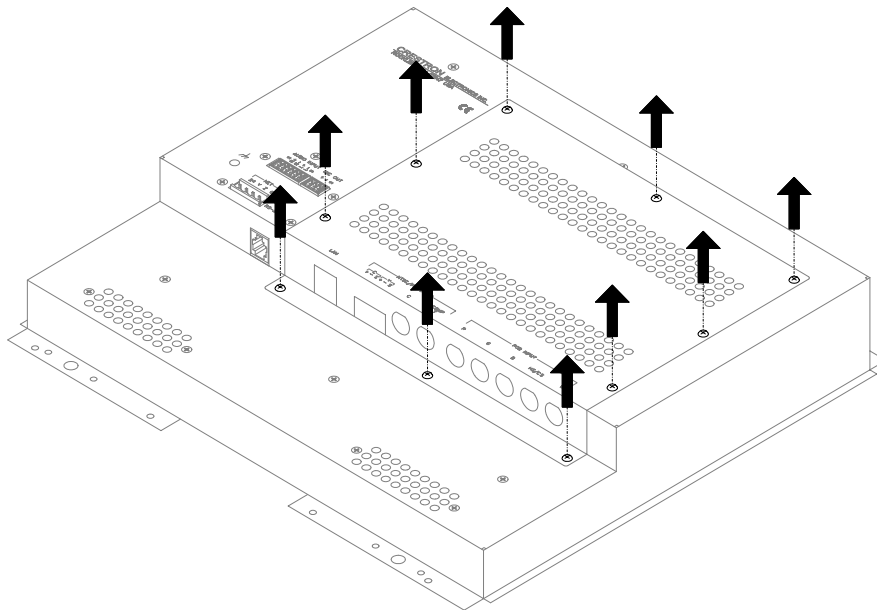

CAUTION: The connectors of any optional card that is already installed may have to be aligned slightly to allow the rear cover to be removed. Align the connectors **carefully** to prevent damage to the card, cover, or touchpanel.

3. Remove the touchpanel rear cover by sliding it towards the bottom of the touchpanel as shown below.

Remove Touchpanel Rear Cover

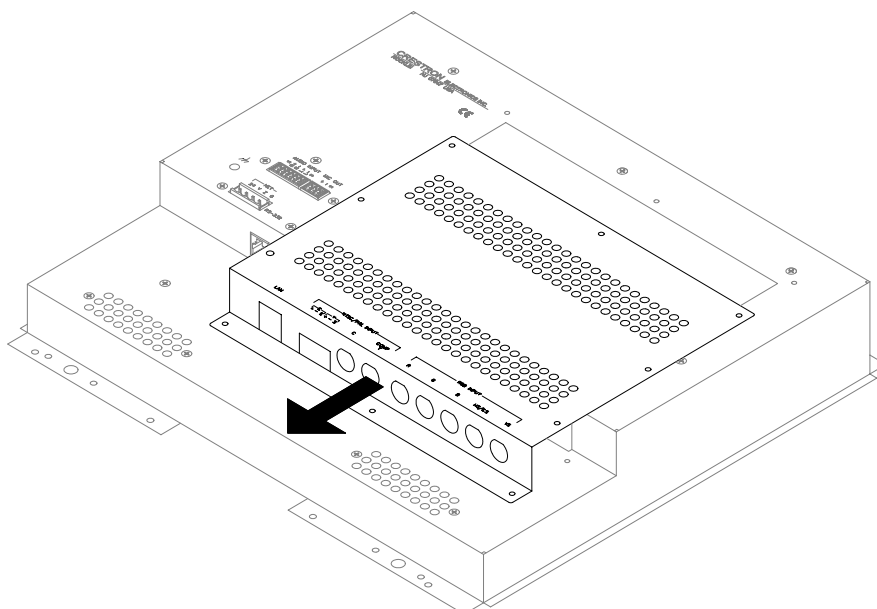

4. Refer to the diagram below. Using a #1 Phillips screwdriver, loosen and remove the **two** screws that secure the PCB blank plate and remove the plate.

Remove PCB Blank Plate

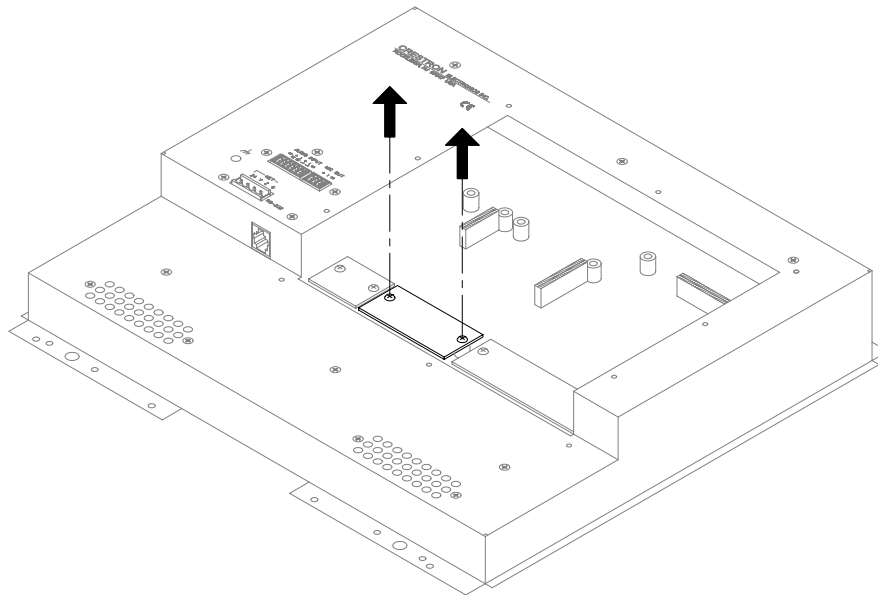

5. As shown below, align the pins on the touchpanel interface connector of the TPS-VIDL with the touchpanel motherboard connector.

Install TPS-VIDL

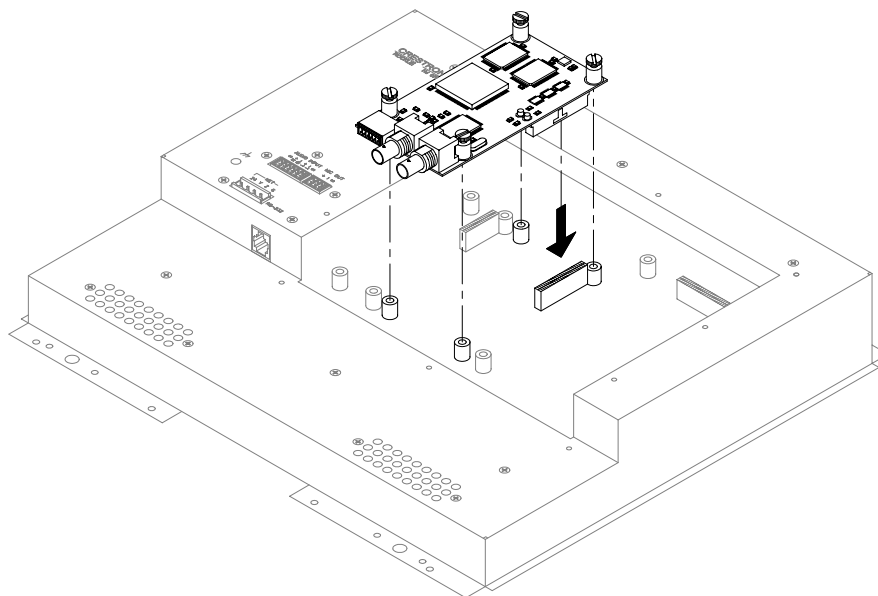

6. **DO NOT** force pins into connector. Press TPS-VIDL until pins are fully seated. Make sure that the mounted screws align with mounting posts of the motherboard.
7. Tighten the card mounting screws to **finger-tight**.

CAUTION: The TPS-VIDL connectors may have to be aligned slightly to fit through the openings in the rear cover. Align the connectors of this card (or any other optional card that is installed) **carefully** to prevent damage to the card, cover, or touchpanel.

8. As shown below, install the touchpanel rear cover by sliding it over the TPS-VIDL connectors.

Install Touchpanel Rear Cover

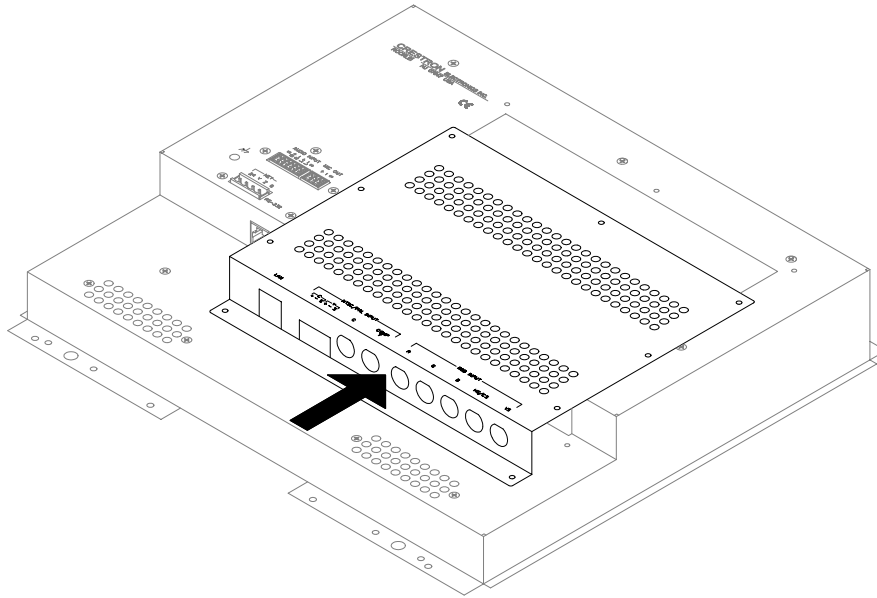

9. Refer to the diagram below. Using a #1 Phillips 1/4-inch hex bit and an inch-pound torque driver, install 10 screws and tighten to **4-inch pounds** (0.45 Newton-meters) to secure cover.

Install Touchpanel Rear Cover Screws

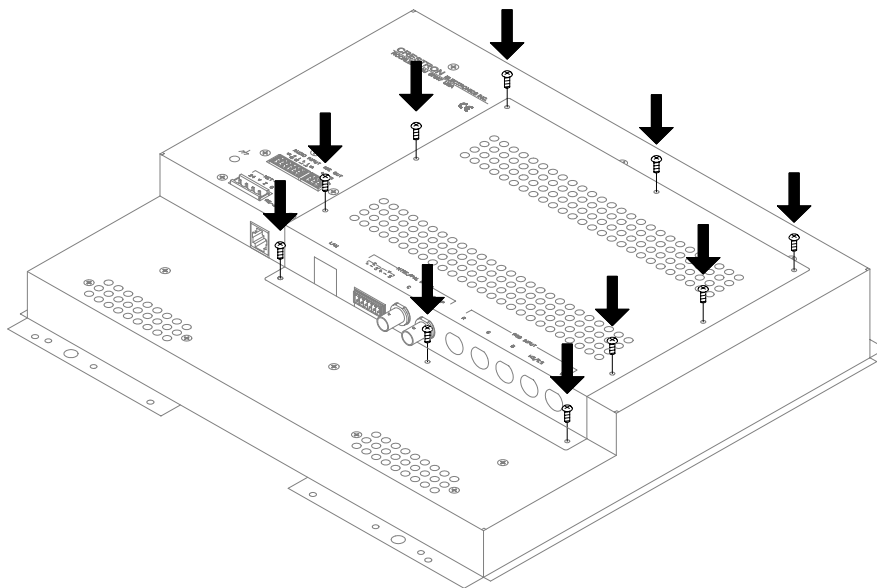

NOTE: Depending upon the individual installation, video connectors #1 or #2 may be used. The input signals are identical, only the connector type is different.

10. Refer to the diagram below and make the appropriate S-video or composite video connection(s) as shown.

Attach Appropriate Video Cables

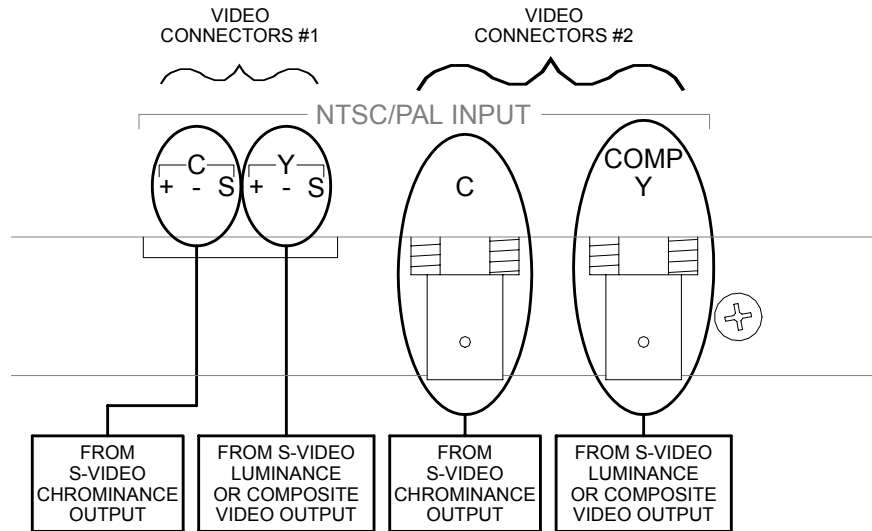

NOTE: Refer to the latest revision of the TPS-5000L, TPS-6000L, or TPS-TPI Operations & Installation Guide (Doc. 5825, 5783, or 5855, respectively) or, if applicable, BB-5000 or BB-6000 Installation Guide (Doc. 5826 or 5827, respectively) for the proper installation procedure of the touchpanel. The latest software version of the Operations & Installation Guides can be obtained from the Downloads page (MANUAL Library) of Crestron’s website (www.crestron.com).

NOTE: Refer to the latest revision of the TPS-5000L, TPS-6000L, or TPS-TPI Operations & Installation Guide (Doc. 5825, 5783, or 5855, respectively) to configure the touchpanel for video input.

Problem Solving

Troubleshooting

The table below provides corrective action for possible trouble situations. If further assistance is required, please contact a Crestron technical support representative.

TPS-VIDL Troubleshooting

TROUBLE	POSSIBLE CAUSE(S)	CORRECTIVE ACTION
Video window of touchpanel has no display.	Improper video connection(s).	Verify proper connections at NTSC/PAL INPUT ports.
	Incorrect video format selected.	Select proper video format or auto-detect in touchpanel configuration setup menu.
	Incorrect firmware/software.	Upgrade firmware/software versions as per those listed in the "Leading Specifications" section of this guide.
	Incorrect VT Pro-e project file loaded.	Make sure that video window object resides in project, re-compile, and reload.
	TPS-VIDL improperly installed.	Follow installation procedures in this guide.
	Damaged connector pins.	Inspect connector pins. If bent, carefully re-straighten. If broken, contact Crestron technical support.

Further Inquiries

If after reviewing this Operations & Installations Guide, you cannot locate specific information or have questions, please take advantage of Crestron's award winning technical support team by calling:

- In the US and Canada, call Crestron's corporate headquarters at 1-888-CRESTRON [1-888-273-7876] or 1-201-767-3400.
- In Europe, call Crestron International at +32-15-50-99-50.
- In Asia, call Crestron Asia at +852-2341-2016.
- In Latin America, call Crestron Latin America at +5255-5093-2160.
- In Australia, call Crestron Pacific at +613-9480-2999.

For local support from exclusive Crestron factory-trained personnel in New Zealand call Amber Technologies at +649-410-8382.

Return and Warranty Policies

Merchandise Returns / Repair Service

1. No merchandise may be returned for credit, exchange, or service without prior authorization from CRESTRON. To obtain warranty service for CRESTRON products, contact the factory and request an RMA (Return Merchandise Authorization) number. Enclose a note specifying the nature of the problem, name and phone number of contact person, RMA number, and return address.
2. Products may be returned for credit, exchange, or service with a CRESTRON Return Merchandise Authorization (RMA) number. Authorized returns must be shipped freight prepaid to CRESTRON, Cresskill, N.J., or its authorized subsidiaries, with RMA number clearly marked on the outside of all cartons. Shipments arriving freight collect or without an RMA number shall be subject to refusal. CRESTRON reserves the right in its sole and absolute discretion to charge a 15% restocking fee, plus shipping costs, on any products returned with an RMA.
3. Return freight charges following repair of items under warranty shall be paid by CRESTRON, shipping by standard ground carrier. In the event repairs are found to be non-warranty, return freight costs shall be paid by the purchaser.

CRESTRON Limited Warranty

CRESTRON ELECTRONICS, Inc. warrants its products to be free from manufacturing defects in materials and workmanship under normal use for a period of three (3) years from the date of purchase from CRESTRON, with the following exceptions: disk drives and any other moving or rotating mechanical parts, pan/tilt heads and power supplies are covered for a period of one (1) year; touchscreen display and overlay components are covered for 90 days; batteries and incandescent lamps are not covered.

This warranty extends to products purchased directly from CRESTRON or an authorized CRESTRON dealer. Purchasers should inquire of the dealer regarding the nature and extent of the dealer's warranty, if any.

CRESTRON shall not be liable to honor the terms of this warranty if the product has been used in any application other than that for which it was intended, or if it has been subjected to misuse, accidental damage, modification, or improper installation procedures. Furthermore, this warranty does not cover any product that has had the serial number altered, defaced, or removed.

This warranty shall be the sole and exclusive remedy to the original purchaser. In no event shall CRESTRON be liable for incidental or consequential damages of any kind (property or economic damages inclusive) arising from the sale or use of this equipment. CRESTRON is not liable for any claim made by a third party or made by the purchaser for a third party.

CRESTRON shall, at its option, repair or replace any product found defective, without charge for parts or labor. Repaired or replaced equipment and parts supplied under this warranty shall be covered only by the unexpired portion of the warranty.

Except as expressly set forth in this warranty, CRESTRON makes no other warranties, expressed or implied, nor authorizes any other party to offer any other party to offer any warranty, including any implied warranties of merchantability or fitness for a particular purpose. Any implied warranties that may be imposed by law are limited to the terms of this limited warranty. This warranty statement supercedes all previous warranties.

Trademark Information

All brand names, product names, and trademarks are the sole property of their respective owners. Windows is a registered trademark of Microsoft Corporation. Windows95/98/Me/XP and WindowsNT/2000 are trademarks of Microsoft Corporation.

This page intentionally left blank.

This page intentionally left blank.



Crestron Electronics, Inc.
15 Volvo Drive Rockleigh, NJ 07647
Tel: 888.CRESTRON
Fax: 201.767.7576
www.crestron.com

*Specifications
subject to change
without notice.*

Doc. 5830
06.00