

Crestron **BB-1700CW**

Wall Mount Back Box for STX-1700CW

Installation Guide



This document was prepared and written by the Technical Documentation department at:



Crestron Electronics, Inc.
15 Volvo Drive
Rockleigh, NJ 07647
1-888-CRESTRON

Contents

Wall Mount Back Box for STX-1700CW: BB-1700CW	1
Introduction	1
Installation	2
Installation During Construction	2
Installation After Construction	5
Further Inquiries	9
Future Updates.....	9
Appendix: Cutout Detail of Supplied Template	10
Return and Warranty Policies	11
Merchandise Returns / Repair Service	11
CRESTRON Limited Warranty.....	11

Wall Mount Back Box for STX-1700CW: BB-1700CW

Introduction

The BB-1700CW back box is wall-mounted hardware that is used to secure the DA-1700CW docking assembly (sold separately). When used with the BB-1700CW, the docking assembly provides operating power, hard-wire communications with a standard Crestron remote control system (herein referred to as the Cresnet system), and recharges the Crestron High Performance Rechargeable Power Pack (ST-BTPN) of a Crestron SmarTouch STX-1700CW compact color touchpanel.

Supplied Components

DESCRIPTION	PART NUMBERS	QUANTITY
Metal, Enclosure	MTEN02571-1	1
Metal, Bracket, Mounting	MTBK02577-1	1
Metal, Bracket, Mounting Support	MTBK02578-1	1
Screw, 6-32, 1/4 "L Steel	SR06-32-0R2500-2	8
Washer, Flat, Steel, B Regular	WA06FL-2	8
Overlay, Template, Wall Cutout	OV40053-1	1

A diagram of the two installation brackets is shown below and three views of the back box enclosure are shown on the next page.

Installation Brackets

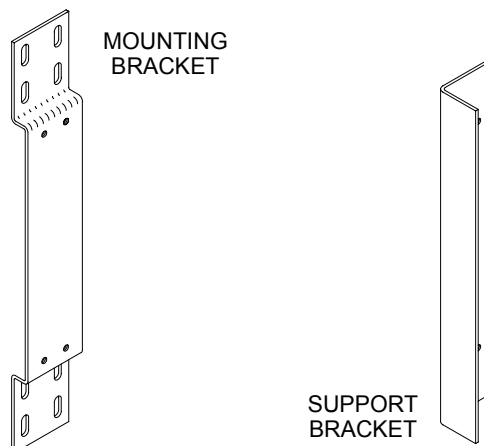

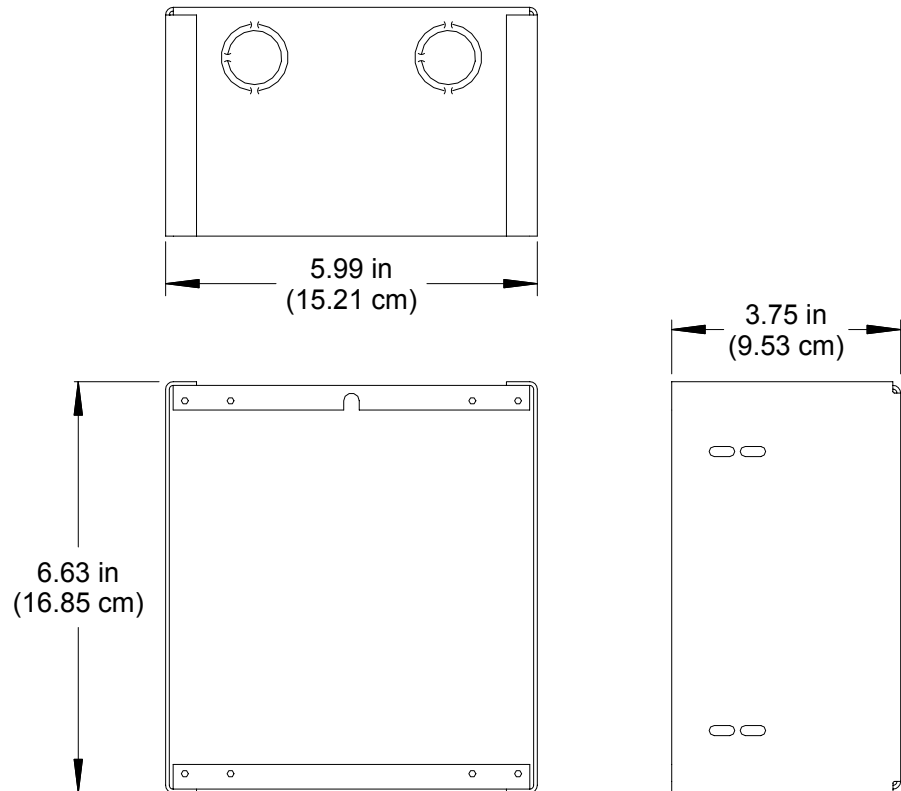
Back Box Enclosure Physical Views and Dimensions

Installation

There are two different methods of installing the BB-1700CW; installation during construction or post-construction installation. Installation during construction describes installation into a room during construction when the room is framed and the gypsum board has not been hung. The post-construction method is used after the rooms are complete and gypsum board has already been hung.

Installation During Construction

This section describes installation into a room during construction when the room is framed and the gypsum board has *not* been hung. Before the gypsum board is hung, complete the following procedure in the order provided. The only tool required is a #2 Phillips screwdriver.

NOTE: This procedure installs the left-side of the back box to the right-side of a framing stud. If installing the back box to the left-side of a stud, reverse the mounting bracket and the mounting support bracket but maintain the orientation of the back box enclosure with the manual unlatching notch at the top.

1. Locate the position and height that the back box (and touchpanel) will be installed.

2. Refer to the diagram below. Position the mounting bracket at the edge of the stud. Through the **upper and bottom-most** mounting bracket slots and using a #2 Phillips screwdriver, secure the bracket to the stud using **four** screws (not supplied).

Secure Mounting Bracket to Stud

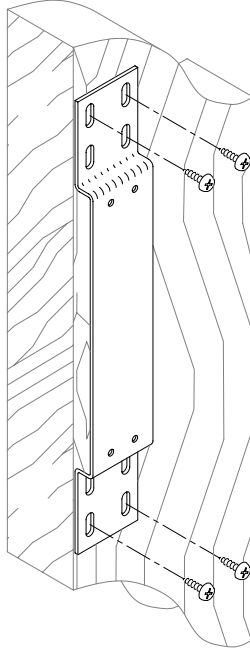

3. Orient the back box enclosure as shown below (notch for manual unlatching **upwards**) and remove an appropriate knockout for the Cresnet wiring.

Back Box Enclosure Orientation

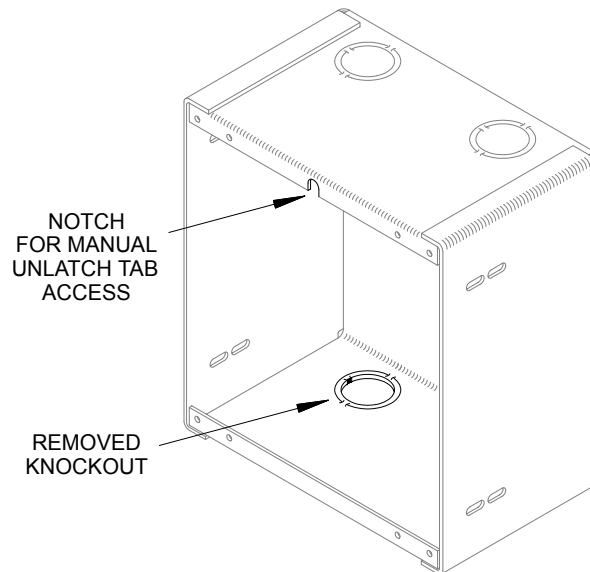

- As shown below, loosely install **four** pan head screws with washers through the inside of the enclosure into the support bracket holes. Tighten screws only **finger-tight** so that final adjustments may be made during step 7 of this procedure.

Loosely Install Support Bracket

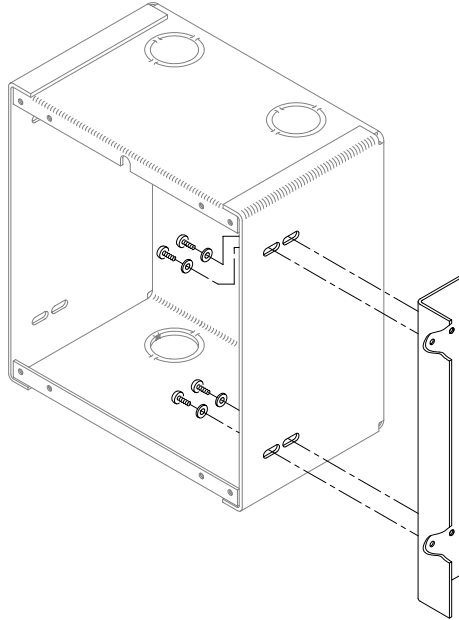

- As shown below, loosely install **four** pan head screws with washers through the inside of the enclosure into the mounting bracket holes. Tighten screws only **finger-tight** so that final adjustments may be made during step 7 of this procedure.

Loosely Secure Enclosure to Mounting Bracket

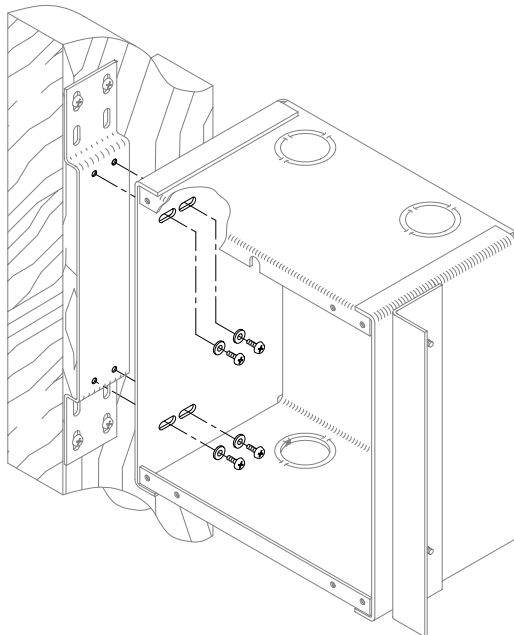

- Feed the Cresnet wiring through the enclosure knockout.

NOTE: To be properly installed, the cutout area of the gypsum board must be cut to within 1/8-inch (0.32 cm) of the outline of the back box enclosure.

NOTE: The next step is performed after the gypsum board is hung. The only tools required are a ruler and a #2 Phillips screwdriver.

7. After the gypsum board is hung, refer to the diagram below. Using a ruler, adjust the back box to approximately **1/16-inch** (0.15 cm) *inward* of the face of the gypsum board to accommodate the distance between the back box and the front panel. Using a #2 Phillips screwdriver, tighten the **four** pair of bracket screws **finger-tight** plus an additional **1/8-turn**.

Adjust Back Box Clearance and Tighten Bracket Screws

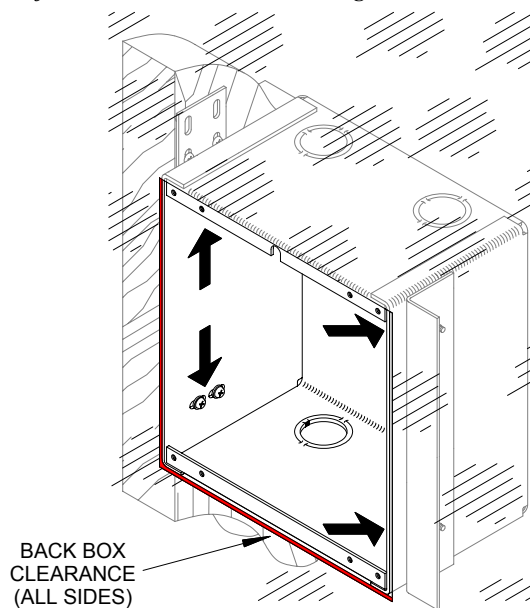

Installation After Construction

This section describes installation when room construction is complete and gypsum board has been hung. Complete the following installation procedure in the order provided. The only tools required are a stud finder (or equivalent), masking tape, gypsum board saw (or equivalent), ruler and a #2 Phillips screwdriver.

NOTE: This procedure installs the left-side of the back box to the right-side of a framing stud. If installing the back box to the left-side of a stud, reverse the mounting bracket and the mounting support bracket but maintain the orientation of the back box enclosure with the manual unlatching notch at the top.

1. Locate an area on the wall that the back box (and touchpanel) will be installed. Make sure that the area is clear of studs, wires, or other obstructions within the installation area.

2. Using a stud finder (or equivalent), locate the right-edge of a stud within the installation area.
3. Align the left dashed, vertical line (labeled STUD EDGE) of the supplied template with the right-edge of the stud. Refer to “Appendix: Cutout Detail of Supplied Template” on page 10 for an illustrative reference.
4. Using masking tape, fasten the supplied template to the wall; verify that the cutout is level.
5. Using a preferred method, transfer the cutout area of the template to the gypsum board at the location of the back box.
6. Using a gypsum board saw (or equivalent), cut the rectangular area through the wall.
7. Remove the template and cutout area.

NOTE: To prevent the mounting bracket from falling into the wall cavity, it is recommended to tie a safety string to the bracket when performing the next step.

8. Refer to the diagram below. Through the cut out area, position the mounting bracket at the edge of the stud (flush with the back-side of the gypsum board) and **vertically centered** in the cut-out area. Through the mounting bracket slots **closest to the center** of the bracket and using a #2 Phillips screwdriver, secure the bracket to the stud using **four** screws (not supplied).

Secure Mounting Bracket to Stud

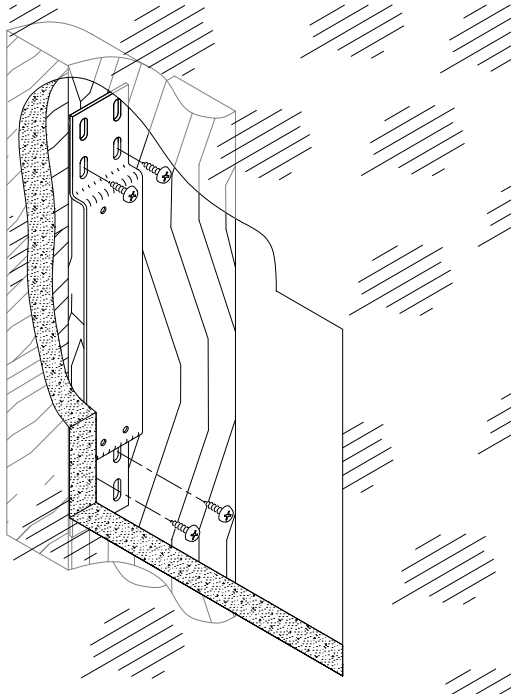

9. Orient the back box enclosure as shown below (notch for manual unlatching **upwards**) and remove an appropriate knockout for the Cresnet wiring.

Back Box Enclosure Orientation

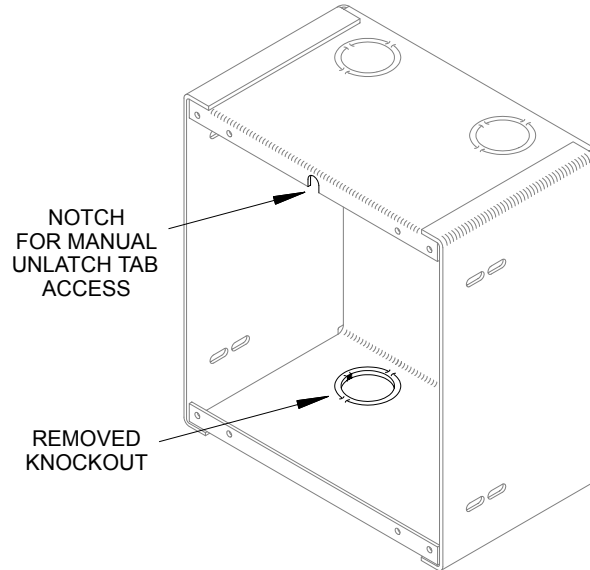

10. As shown below, loosely install **four** pan head screws with washers through the inside of the enclosure into the support bracket holes. Tighten screws only **finger-tight** so that final adjustments may be made during step 14 of this procedure.

Loosely Install Support Bracket

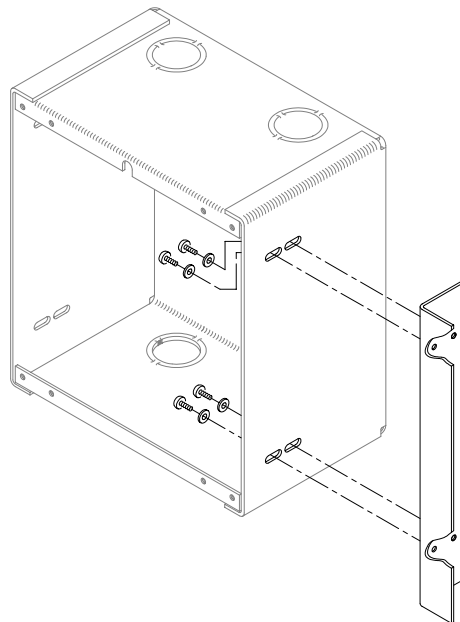

11. Position the back box enclosure near the cut-out area and feed the Cresnet wiring through the enclosure knockout.

12. Making sure that the support bracket is behind the gypsum board, position the enclosure into the cutout area.
13. As shown below, loosely install **four** pan head screws with washers through the inside of the enclosure into the mounting bracket holes. Tighten screws only **finger-tight** so that final adjustments may be made during the next step of this procedure.

Loosely Secure Enclosure to Mounting Bracket

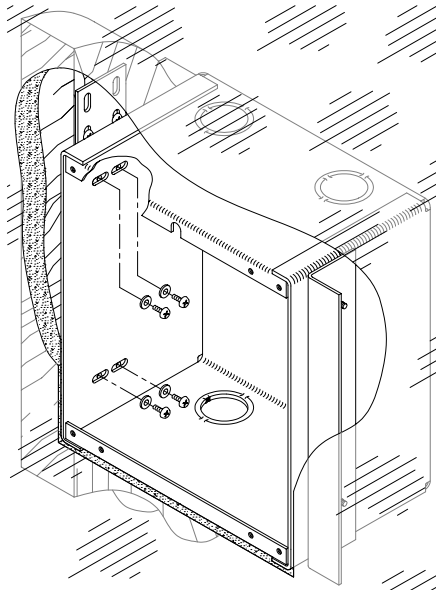

14. As shown below, use a ruler to adjust the back box to approximately **1/16-inch** (0.15 cm) *inward* of the face of the gypsum board to accommodate the distance between the back box and the front panel. Using a #2 Phillips screwdriver, tighten the **four** pair of bracket screws **finger-tight** plus an additional **1/8-turn**.

Adjust Back Box Clearance and Tighten Bracket Screws

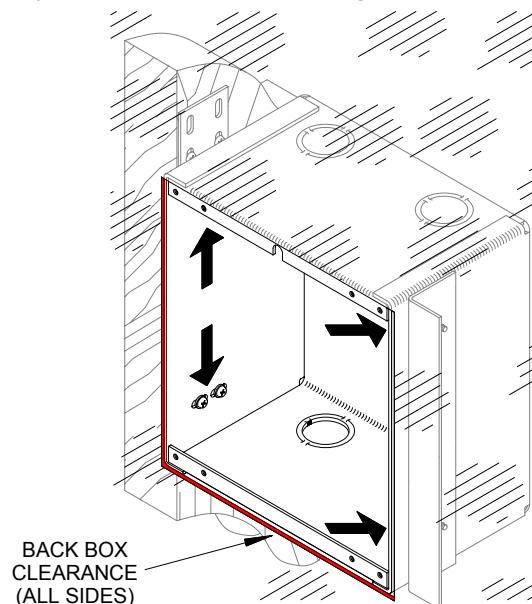

Further Inquiries

If after reviewing this Installation Guide for the BB-1700CW, you cannot locate specific information or have questions, please take advantage of Crestron's award winning customer service team by calling:

- In the US and Canada, call Crestron's corporate headquarters at 1-888-CRESTRON [1-888-273-7876].
- In Europe, call Crestron International at +32-15-50-99-50.
- In Asia, call Crestron Asia at +852-2341-2016.
- In Latin America, call Crestron Latin America at +5255-5093-2160.
- In Australia and New Zealand, call Crestron Control Solutions at +61-2-9737-8203.

Future Updates

As Crestron adds improvements to the BB-1700CW, additional information may be made available as manual updates. These updates are solely electronic and serve as intermediary supplements prior to the release of a complete technical documentation revision.

Check the Crestron website (www.crestron.com) periodically for manual update availability and its relevance. Updates are available from the Download | Product Manuals section and are identified as an "Addendum" in the Download column.

Appendix: Cutout Detail of Supplied Template

Crestron recommends that the template supplied with the BB-1700CW be used to avoid any error. However, if the template becomes lost or unusable, the dimensions of the cutout area are shown below.

NOTE: Depending on the specific installation, the BB-1700CW may be installed either on the left or right side of a stud.

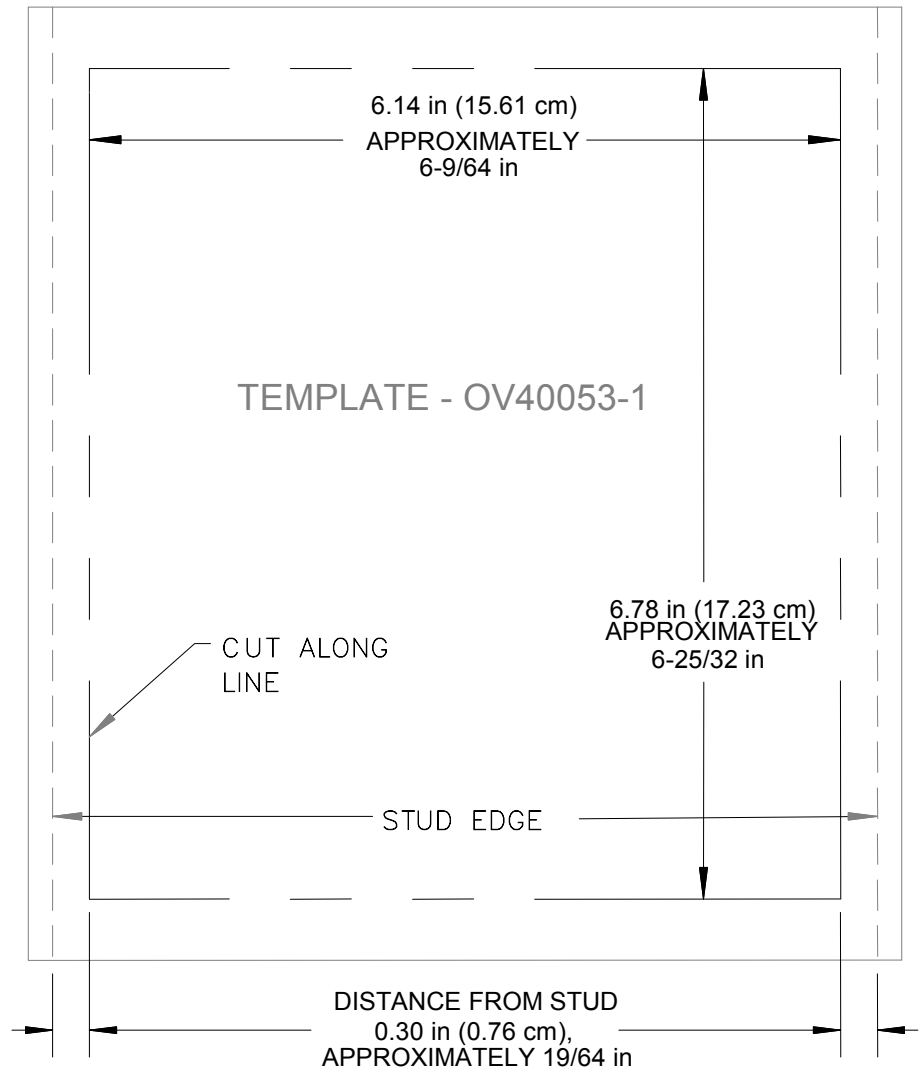

Return and Warranty Policies

Merchandise Returns / Repair Service

1. No merchandise may be returned for credit, exchange, or service without prior authorization from CRESTRON. To obtain warranty service for CRESTRON products, contact the factory and request an RMA (Return Merchandise Authorization) number. Enclose a note specifying the nature of the problem, name and phone number of contact person, RMA number, and return address.
2. Products may be returned for credit, exchange, or service with a CRESTRON Return Merchandise Authorization (RMA) number. Authorized returns must be shipped freight prepaid to CRESTRON, 6 Volvo Drive, Rockleigh, N.J., or its authorized subsidiaries, with RMA number clearly marked on the outside of all cartons. Shipments arriving freight collect or without an RMA number shall be subject to refusal. CRESTRON reserves the right in its sole and absolute discretion to charge a 15% restocking fee, plus shipping costs, on any products returned with an RMA.
3. Return freight charges following repair of items under warranty shall be paid by CRESTRON, shipping by standard ground carrier. In the event repairs are found to be non-warranty, return freight costs shall be paid by the purchaser.

CRESTRON Limited Warranty

CRESTRON ELECTRONICS, Inc. warrants its products to be free from manufacturing defects in materials and workmanship under normal use for a period of three (3) years from the date of purchase from CRESTRON, with the following exceptions: disk drives and any other moving or rotating mechanical parts, pan/tilt heads and power supplies are covered for a period of one (1) year; touchscreen display and overlay components are covered for 90 days; batteries and incandescent lamps are not covered.

This warranty extends to products purchased directly from CRESTRON or an authorized CRESTRON dealer. Purchasers should inquire of the dealer regarding the nature and extent of the dealer's warranty, if any.

CRESTRON shall not be liable to honor the terms of this warranty if the product has been used in any application other than that for which it was intended, or if it has been subjected to misuse, accidental damage, modification, or improper installation procedures. Furthermore, this warranty does not cover any product that has had the serial number altered, defaced, or removed.

This warranty shall be the sole and exclusive remedy to the original purchaser. In no event shall CRESTRON be liable for incidental or consequential damages of any kind (property or economic damages inclusive) arising from the sale or use of this equipment. CRESTRON is not liable for any claim made by a third party or made by the purchaser for a third party.

CRESTRON shall, at its option, repair or replace any product found defective, without charge for parts or labor. Repaired or replaced equipment and parts supplied under this warranty shall be covered only by the unexpired portion of the warranty.

Except as expressly set forth in this warranty, CRESTRON makes no other warranties, expressed or implied, nor authorizes any other party to offer any warranty, including any implied warranties of merchantability or fitness for a particular purpose. Any implied warranties that may be imposed by law are limited to the terms of this limited warranty. This warranty statement supercedes all previous warranties.

Trademark Information

All brand names, product names, and trademarks are the sole property of their respective owners. Windows is a registered trademark of Microsoft Corporation. Windows95/98/Me/XP and WindowsNT/2000 are trademarks of Microsoft Corporation.



Crestron Electronics, Inc.
15 Volvo Drive Rockleigh, NJ 07647
Tel: 888.CRESTRON
Fax: 201.767.7576
www.crestron.com

Installation Guide – DOC. 6105
08.02

Specifications subject to
change without notice.